



PDHonline Course C707 (3 PDH)

Wetland Restoration & Enhancement Design

Instructor: John Huang, Ph.D., PE and John Poullain, PE

2020

PDH Online | PDH Center

5272 Meadow Estates Drive
Fairfax, VA 22030-6658
Phone: 703-988-0088
www.PDHonline.com

An Approved Continuing Education Provider

Chapter 13

**Wetland Restoration,
Enhancement, or Creation**



Issued April 2008

Cover: Mississippi cypress

The U.S. Department of Agriculture (USDA) prohibits discrimination in all its programs and activities on the basis of race, color, national origin, age, disability, and where applicable, sex, marital status, familial status, parental status, religion, sexual orientation, genetic information, political beliefs, reprisal, or because all or a part of an individual's income is derived from any public assistance program. (Not all prohibited bases apply to all programs.) Persons with disabilities who require alternative means for communication of program information (Braille, large print, audiotape, etc.) should contact USDA's TARGET Center at (202) 720-2600 (voice and TDD). To file a complaint of discrimination, write to USDA, Director, Office of Civil Rights, 1400 Independence Avenue, SW., Washington, DC 20250-9410, or call (800) 795-3272 (voice) or (202) 720-6382 (TDD). USDA is an equal opportunity provider and employer.

Preface

Chapter 13, Wetland Restoration, Enhancement, or Creation is one of the 19 chapters of the U. S. Department of Agriculture (USDA), Natural Resources Conservation Service (NRCS) National Engineering Handbook (NEH), Part 650. This chapter is designated Engineering Field Handbook (EFH), Part 650.13. Other chapters that are pertinent to and should be referenced in use with chapter 13 are:

Part 650.01 Engineering Surveys

Part 650.02 Estimating Runoff

Part 650.03 Hydraulics

Part 650.04 Elementary Soils Engineering

Part 650.05 Preparation of Engineering Plans

Part 650.06 Structures

Part 650.07 Grassed Waterways and Outlets

Part 650.08 Terraces

Part 650.09 Diversions

Part 650.10 Gully Treatment

Part 650.11 Ponds and Reservoirs

Part 650.12 Springs and Wells

Part 650.14 Drainage

Part 650.15 Irrigation

Part 650.16 Streambank and Shoreline Protection

Part 650.17 Construction and Construction Materials

Part 650.18 Soil Bioengineering for Upland Slope Protection and Erosion Reduction

Part 650.19 Hydrology Tools for Wetland Determination

Part 650.13 was last revised in May 1997. This revision was done to incorporate significant advances in the science and practice of wetland restoration, enhancement, and creation.

Acknowledgments

This revision was prepared under the general guidance of **Bob Snieckus**, national landscape architect, NRCS, Washington, DC; **Dr. Norman Melvin, III**, Wetland Team Leader, NRCS Central National Technology Support Center (CNTSC), Fort Worth, Texas; and the following revision committee:

Dr. Norman Melvin, III, Leader, Wetland Team, NRCS CNTSC, Fort Worth, Texas

Kathryn Boyer, fisheries biologist, NRCS West National Technology Support Center (WNTSC), Portland, Oregon

Jennifer Anderson-Cruz, biologist, NRCS, Des Moines, Iowa

Greg Kidd, WRP biologist, NRCS, Madison, Wisconsin

Chris Hoag, wetland plant ecologist, NRCS Plant Materials Center, Aberdeen, Idaho

Doug Helmers, Wetland Team Leader, NRCS, Chillicothe, Missouri

Randy Childress, resource engineer, NRCS, Hope, Arkansas

Edmund Giering, state conservation engineer, NRCS, Alexandria, Louisiana

Editing and compilation was performed by **Richard Weber**, wetland hydraulic engineer, Wetland Team, CNTSC, Fort Worth, Texas.

Reviews were provided by:

Lee Davis, biologist, Wetland Team, CNTSC, Fort Worth, Texas

Dean Renner, stream mechanics engineer, NRCS, Olympia, Washington

Additional contributions were provided by:

Kale Gullett, fisheries biologist, NRCS East National Technology Support Center (ENTSC), Greensboro, North Carolina

The original document was published as *Dikes and Levees—Wildlife Wetland Development* and revised under its current title in 1997. The original document and revisions were compiled, edited, and reviewed by individuals representing NRCS, the U.S. Army Corps of Engineers (USACE), U.S. Fish and Wildlife Service (USFWS), and U.S. Environmental Protection Agency (EPA).

Contents	650.1300 Introduction	13-1
	(a) Purpose and scope	13-1
	(b) Background.....	13-1
	(c) Definitions of wetland restoration, creation, and enhancement.....	13-2
	(d) Information and agency sources	13-2
	650.1301 HGM wetland classes	13-3
	(a) Depressional wetland class.....	13-3
	(b) Riverine wetland class.....	13-4
	(c) Slope wetland class.....	13-7
	(d) Mineral soil flat wetland class	13-8
	(e) Organic soil flat wetland class	13-9
	(f) Lacustrine fringe wetland class.....	13-9
	(g) Estuarine fringe wetland class	13-10
	650.1302 Wetland processes and characteristics	13-18
	(a) Physical processes	13-18
	(b) Chemical processes	13-19
	(c) Biological processes	13-20
	650.1303 Pre-implementation wetland planning	13-21
	(a) Planning step 1—Define the problem.....	13-21
	(b) Planning step 2—Determine objectives	13-21
	(c) Planning step 3—Resource inventory and planning step 4— Data analysis	13-25
	(d) Planning step 5—Formulate alternatives.....	13-37
	(e) Planning step 6—Evaluate alternatives.....	13-37
	(f) Planning step 7—Make decisions.....	13-38
	650.1304 Design	13-38
	(a) Data collection.....	13-38
	(b) Hydrodynamics of wetland systems	13-55
	(c) Design of structural components	13-63
	(d) Vegetation design	13-88
	650.1305 Construction	13-96
	(a) Roles and responsibilities	13-96
	(b) Types of contracts	13-97
	(c) Quality assurance	13-98
	(d) Construction of the wetland	13-98
	(e) General considerations for structural components.....	13-101
	(f) Wetland soils as sources of plant materials	13-103
	(g) Vegetative establishment.....	13-103

650.1306	Management	13-104
	(a) Prairie pothole management	13-104
	(b) Seasonally flooded impoundments for wildlife	13-105
	(c) Bottomland hardwood management	13-107
	(d) Greentree reservoir/moist soil unit management	13-108
	(e) Ecology of wetland connectivity.....	13-108
	(f) Herpetofauna	13-111
650.1307	References	13-117

Appendices

Appendix 13A	Glossary	13A-1
Appendix 13B	List of Symbols	13B-1
Appendix 13C	Wetland Planning Checklist	13C-1
Appendix 13D	Monitoring Checklist	13D-1

Tables	Table 13-1	Common wetland functions and processes	13-22
	Table 13-2	Soil characteristics related to dikes	13-41
	Table 13-3	Hydraulic conductivity vs. soil texture	13-48
	Table 13-4	Additional height for wave action	13-65
	Table 13-5	Length of drain blocks by USCS soil class	13-82
	Table 13-6	Recommended removal rates for basin drainage	13-85
	Table 13-7	Key to natural regeneration vs. planting: forested wetland types	13-90
	Table 13-8	Key to natural regeneration vs. planting: emergent marsh wetland types	13-90
	Table 13-9	Flood tolerances of several species in the lower Mississippi Delta	13-92
	Table 13-10	Construction equipment vs. site conditions	13-102
	Table 13-11	Passage barriers and solutions	13-110

Figures	Figure 13-1	HGM wetland types	13-11
	Figure 13-2	Hydrodynamics of HGM wetland classes	13-13
	Figure 13-3	Restoration of flood plain macrotopography	13-18
	Figure 13-4	Microtopography feature created by a blown down tree	13-18
	Figure 13-5	Restoration of microtopography on gilgai soils on a riverine wetland	13-18
	Figure 13-6	Wetland vegetation has a role in many wetland functions	13-21
	Figure 13-7	Wetland functions and values	13-26
	Figure 13-8	Riverine wetland planning may involve streamflow data collection	13-29
	Figure 13-9	Wetlands near airports can pose waterfowl management problems	13-30
	Figure 13-10	Beavers can be a nuisance animal	13-32
	Figure 13-11	Muskrats can damage earthen dikes	13-32
	Figure 13-12	Salmonids may be adversely affected by water warmed by wetlands	13-33
	Figure 13-13	Wetlands provide nonconsumptive recreational use	13-33
	Figure 13-14	Wetlands provide open space in manmade landscapes	13-34
	Figure 13-15	Surveys should locate existing water conveyance structures	13-39
	Figure 13-16	Survey-grade GPS equipment increases the efficiency of topographic surveys	13-39
	Figure 13-17	Soils investigation	13-40
	Figure 13-18	Downward movement detected by wells and piezometers	13-47
	Figure 13-19	Upward movement detected by wells and piezometers	13-47
	Figure 13-20	Hydrology enhancement with pumped ground water	13-51

Figure 13-21	Simplified water budgets can be readily analyzed using spreadsheet tools	13-57
Figure 13-22	Schematic of a riverine wetland project incorporating a headwater breach of a levee	13-60
Figure 13-23	Dynamic riverine project incorporating a backwater breach	13-61
Figure 13-24	Section through dike	13-65
Figure 13-25	Dike for internal water control	13-66
Figure 13-26	Use of a banquette at a channel crossing	13-67
Figure 13-27	Methods of increasing the stability of a dike	13-67
Figure 13-28	Structure selection guide	13-69
Figure 13-29	Schematic layout of a typical sheet pile weir installation	13-73
Figure 13-30	Cut pipe culvert	13-76
Figure 13-31	Sheet pile vortex weir	13-76
Figure 13-32	Sheet pile weir with stoplogs	13-77
Figure 13-33	Pre-cast stoplog structures	13-77
Figure 13-34	Pre-fabricated stoplog structures	13-77
Figure 13-35	CMP riser with stoplogs	13-77
Figure 13-36	Beaver protection	13-78
Figure 13-37	Riser with canopy barrel inlet	13-78
Figure 13-38	Plug riser	13-78
Figure 13-39	Armoring auxiliary spillway with concrete and riprap	13-79
Figure 13-40	Fish passage between a stream and a wetland	13-80
Figure 13-41	Schematics of ditch plug layout	13-83
Figure 13-42	Schematics of rock check dam	13-84
Figure 13-43	Flowchart for vegetation design decisions	13-89
Figure 13-44	Restoration dominated by reed canarygrass (<i>Phalaris arundinacea</i>), Washington State	13-91

Figure 13-45	Natural regeneration on an emergent wetland, California	13-91
Figure 13-46	Plant species must tolerate site conditions	13-92
Figure 13-47	Species typical of herbaceous wetlands	13-92
Figure 13-48	Bareroot nursery stock	13-94
Figure 13-49	Modified planter for acorns	13-95
Figure 13-50	Construction in a riverine wetland project	13-98
Figure 13-51	Dewatering a pit to be filled as part of restoration	13-99
Figure 13-52	Wetland construction often requires low ground pressure equipment	13-100
Figure 13-53	Wetlands containing a mixture of open water and dense vegetation provide productive waterfowl habitat in a prairie pothole	13-104
Figure 13-54	Enhanced wetlands provide important wildlife habitat in arid landscapes	13-105
Figure 13-55	Diked wetlands are often designed with various water depths to increase vegetative diversity and allow boat access	13-106
Figure 13-56	Bottomland hardwoods require many years to achieve desired functions and values	13-107
Figure 13-57	Herpetofauna, such as turtles, utilize wetlands for all or a part of their life cycle	13-111
Figure 13-58	Rock basking structure	13-112
Figure 13-59	Rock hibernacula	13-113
Figure 13-60	Wood hibernacula	13-114
Figure 13-61	Reptile nesting structure	13-115

650.1300 Introduction**(a) Purpose and scope**

The planning, design, implementation, and monitoring of wetland restoration, enhancement, or creation project requires a multidisciplinary approach involving the disciplines of engineering, biology, geology, and soil science, among others. The scope of this chapter has been expanded beyond the traditional National Engineering Handbook (NEH), Engineering Field Handbook (EFH) focus to reflect this approach. Included in the scope is the science of wetlands and tools to assess wetland function. Wetlands, for the purpose of this chapter, are defined as areas that have anaerobic soil conditions due to the presence of water, at or near the surface for a sufficient duration to support wetland vegetation. This chapter is intended to provide field personnel with guidance in restoring, enhancing, or creating wetlands. The material included is intended to be used with the policy contained in the Electronic Field Office Technical Guide (eFOTG).

The scope of this chapter does not include the delineation of wetlands for the purpose of the National Food Security Act Manual (NFSAM). Guidance on engineering hydrology for wetland delineation can be found in the EFH650.19, Hydrology Tools for Wetland Determination. The scope also does not include wetland determinations in accordance with Section 404 of the Clean Water Act. The U.S. Army Corps of Engineers (USACE) 1987 Manual (Technical Report Y-87-1, Wetlands Delineation Manual) should be referenced for this guidance when dealing with National Environmental Policy Act (NEPA) and wetland conservation policy issues.

Also not included in the scope of this chapter are constructed wetlands. This treatment provides conditions that support hydrophytic vegetation and are used for the treatment of specific water pollutants. Information on constructed wetlands is available in NEH, Part 637.03, Constructed Wetlands.

(b) Background

Wetlands types vary widely throughout the United States. Many efforts have been made to classify wetlands according to factors such as geographic location, biological function, hydrologic function, and species composition. The method currently in use by the U.S. Department of Agriculture (USDA) Natural Resources Conservation Service (NRCS) and USACE for classification of wetlands is one that uses the three factors: geomorphic setting, water source, and hydrodynamics. Using these factors, seven broad hydrogeomorphic (HGM) classes have been defined by Brinson (1994). Using the broad framework of HGM, local and regional subclasses may be established. The hydrogeomorphic method also provides a framework for development of functional assessments based on the three HGM factors.

It is important to note that wetland vegetation and biological functions are critically important, even though they are not included in the top hierarchy of the HGM system. The HGM system requires an understanding of the relationships between biological function and the wetland's physical setting.

Planning of wetland projects should include an assessment based on HGM principles during the resource inventory phase. An HGM assessment of pre-project conditions will determine those wetland functions that are present and the current capacity of those functions. This forms the basis of a rational plan to restore functions or increase their capacity. It allows the analysis of the costs, benefits, and alternatives. The USACE is in the process of developing regional guidebooks for HGM functional assessments across the country. The available guidebooks can be assessed at <http://el.erdc.usace.army.mil/wetlands/guidebooks.html>.

This Web site also includes the USACE Technical Report WRP-DE-4, which describes the HGM approach, and Technical Report WRP-DE-9, which provides information on the development of a local HGM assessment.

(c) Definitions of wetland restoration, creation, and enhancement

Wetland restoration is defined as the rehabilitation of a degraded wetland or the reestablishment of a wetland so that soils, hydrology, vegetative community, and habitat are a close approximation of the original natural condition that existed prior to modification to the extent practicable (National Conservation Practice Standard (CPS) 657). In this definition, rehabilitation is restoring an existing, but degraded wetland back to its original condition. Reestablishment is the process of restoring a lost wetland back to its original condition.

Where conditions permit, restoration usually provides the most cost-effective improvement in wetland function, with the greatest increase of function of the most variables. In some cases, the original hydrologic factors that created the wetland's timing, duration, and depth of water no longer exist. If other sources of water can be supplied in a manner which provides self-sustaining hydrologic conditions over the long term, the effort can be considered a restoration.

Wetland enhancement is defined as the rehabilitation or reestablishment of a degraded wetland, and/or the modification of an existing wetland, which augments specific site conditions for specific species or purposes, possibly at the expense of other functions and other species (CPS 659). An enhancement project is still in the original wetland geomorphic setting, but its functions have been altered to add additional benefit for particular species or purposes. For example, an increase in water depth (**hydrologic regime**), duration of water presence (**hydroperiod**), or a change in plant community from the one originally supported by the natural wetland is considered to be an enhancement. An enhancement usually requires more management and is more expensive to construct. It augments specific functions, often at the expense of other functions.

Wetland creation is defined as the creation of a wetland on a site that was historically nonwetland (CPS 658). The creation will provide wetland hydrology on a geomorphic setting that was not originally wetland. Wetland creations usually have the highest cost and management requirements. They are usually done for only one function such as providing wildlife habitat, educational opportunities, or improving the quality

of water from nonpoint source runoff. A created wetland is not the same as a constructed wetland, which is built to treat point and nonpoint sources of pollution on sites which did not naturally support wetlands.

(d) Information and agency sources

Several Federal agencies, state natural resources agencies, and a number of private conservation groups publish pertinent information that has been used as background information for this chapter. A bibliography has been included. Among the Federal agencies that contributed to this chapter were the NRCS, USACE, U.S. Fish and Wildlife Service (USFWS), U.S. Environmental Protection Agency (EPA), USDA Forest Service (FS), Tennessee Valley Authority (TVA), and Office of Surface Mining (OSM).

650.1301 HGM wetland classes

This section covers descriptions of the seven HGM wetland types, ways in which functions are altered, and strategies for restoration or enhancement. By definition, wetland creation is not included because creations are performed outside the geomorphic setting of a wetland. Strategies for increasing function are presented in the context of restoration. Specific enhancement strategies are included when appropriate. Examples of the seven HGM wetland classes are illustrated in figure 13–1. Figure 13–2 provides schematic descriptions of the hydrodynamics of the HGM wetland types.

(a) Depressional wetland class

(1) Geomorphic setting

Depressional wetlands exist in topographic depressions which create storage basins. The depressions may have been created by water, wind, glaciation, or other processes. Wind-created depressions include playas in the High Plains and Intermountain Region of the Western United States. Glacier-formed depressions include prairie potholes common to the Upper Midwest.

(2) Dominant water source

The dominant water sources are direct precipitation, overland flow from precipitation events, and ground water discharge. In prairie potholes, ground water may be the most significant source when the drainage area of the wetland is small. In High Plains playas, surface runoff may be the dominant water source. Vernal pools in California have precipitation as the dominant water source.

(3) Hydrodynamics

The dominant direction of water movement is vertical. Vertical loss may be upward through evapotranspiration or downward through percolation. High Plains playas and California vernal pools are examples of arid region wetlands which have very little downward movement because of low permeability soils. Almost all loss is upward through evapotranspiration. In prairie potholes of the Upper Midwest and Northern Plains, downward water movement may find its way into the local ground water table or move as interflow into adjacent depressions.

Discharge depressional wetlands gain more water from ground water than they lose. The water table grades into these wetlands. The primary loss of water is through evapotranspiration. Prairie potholes commonly act as discharge wetlands. **Recharge** wetlands gain little or no ground water inflow. They receive water from surface runoff and direct precipitation. If the length of the hydroperiod and soil permeability allow, they may recharge water into the local ground water table, and ground water recharge may be a significant wetland function. In arid region playas, almost all of the water is lost through evapotranspiration. High Plains playas usually act as recharge wetlands. **Flow-through** wetlands both receive and discharge ground water. The net flow direction may change seasonally or with wet or dry years. Prairie potholes, for example, can act as discharge, recharge, or flow-through wetlands, depending on the time of the year.

(4) Loss of function

Loss of function of depressional wetlands is commonly caused by altering the water balance. Intercepting the surface inflow into the depression is an effective way of changing the wetland hydrology so that the area can be converted to farmland or other uses. In the arid High Plains, construction of storage type terraces above the low permeability wetland soils diverts the surface runoff into the more highly permeable upland soils. In more humid areas, gradient terraces or diversions, which divert the water away from the wetland into another natural outlet, will alter the wetland. Surface ditches or underground pipelines have also been used. In many areas, the local county road system has drastically altered drainage areas with the gradient of ditches and placement of culverts. Changing the land use in the wetland drainage area can alter the hydroperiod and hydrologic regime of the wetland. One of the most common conversions historically has been the conversion of rangeland to irrigated or dry land cropland. No broad statements can be made about the increase or decrease of runoff, which applies to this conversion around the country. The interrelationships between growth stages, evapotranspiration, runoff volume, hydroperiod, and wetland regime must be determined locally, and an appropriate analysis made. Other drainage strategies involve the excavation of pits in the wetland, which move the water stored in broad shallow wetland areas into smaller deeper excavations. In the Nebraska Rainwater Basin area, these pits are utilized as an irrigation water source and serve to receive tailwater from gravity irrigation systems.

(5) Restoration strategies

In the cases where alteration has been caused by on-site drainage or diversion measures, restoration can be accomplished by removing these measures. Storage type terraces can still be allowed to function for erosion control by installing a grassed waterway or pipe outlet into the wetland. Surface ditches can be filled or blocked. Sediment which has partially filled the depression from cropland erosion can be removed down to the original wetland substrate. Uplands can be revegetated to control sediment and nutrients moving into the wetland. Excavated pits can be filled with compacted soil. Figure 13–2 exhibits the hydrodynamics of both ground water induced and playa-type depressional wetlands.

(b) Riverine wetland class

(1) Geomorphic setting

Riverine wetlands exist in association with stream corridors. They were formed by fluvial processes. They may be found in the current active flood plain or on successive stream terraces that no longer receive frequent flood flows. Riverine wetland areas are considered to be integral to the function of the entire stream corridor. Their functions are interrelated, and manipulation or restoration of one corridor function will have a direct affect on the function of the remaining corridor. However, wetlands found in the active flood plain are treated somewhat differently than those found on terraces. Restoration, enhancement, or creation of riverine wetlands should be considered in the context of the stream corridor. Stream restorations should be planned using the guidance found in NEH, Part 653, Stream Corridor Restoration: Principles, Processes, and Practices. Guidance for design can be located in NEH, Part 654, Stream Restoration Design. Executive Order 11988 requires Federal agencies not to take actions that degrade flood plain functions.

Active flood plains include the portion of the corridor which is in hydrologic and hydraulic connection with the stream. In short, they still periodically receive flood flows.

Active flood plains exhibit many complex features such as oxbows, chutes, scour channels, natural levees, backwater areas, and microtopographic features. Flood plains that are no longer active (flooded during flows in excess of geomorphic bankfull discharge)

may still exhibit remnant flood plain features with wetland hydrology due to surface runoff and ponding. These features can provide valuable wetland functions and should be considered for restoration. Flood plain features subject to flooding are dynamic systems and should be designed for a minimum level of management. Constructed dikes, levees, and water control structures are problematic and have the potential to hinder the natural function of the wetland. Flood plains not currently subject to periodic flooding can include constructed features for improvement of wetland functions. These features are installed for the purpose of replacing the original hydroperiod and regime caused by the stream flood hydrograph. Dikes, levees, and water control structures are more appropriate in these cases.

(2) Dominant water source and hydrodynamics

Water source and hydrodynamics for riverine systems are considered together.

(i) Surface water—The hydrology of the system is defined in terms of the stream's hydrograph. The restored stream will provide out of bank flows and/or maintain a ground water table with a frequency sufficient to support wetland hydrology. Out-of-bank flow rates are those which exceed the **geomorphic bankfull discharge, channel-forming discharge, or dominant discharge**. This discharge is that with a return period frequency from 1 to 3 years, normally, and is often equated to the 2-year peak discharge. It is also the discharge which maintains a stable channel. Guidance on determining this discharge can be found in NEH, Parts 653 and 654. Many areas of the country have regional curve reports developed that define the bankfull discharge return period and discharge rate versus drainage area. Streams that do not provide out-of-bank flows onto their active original flood plain during this discharge can, in certain cases, be restored so that flood flows again access the flood plain.

(ii) Ground water—The ground water surface of riverine wetlands may be perched on low permeability soils in the flood plain and found significantly above the stream ground water surface during baseflow. These wetlands are **episaturated**. Water sources are a combination of flood events, surface runoff from uplands and adjacent flood plain areas, and direct precipitation.

The riverine wetland ground water surface may be directly connected to the stream water surface profile. These wetlands are **endosaturated**. In high permeability flood plain soils, a change in stream water surface translates quickly to the flood plain wetland. In these cases, the stream will support wetland conditions during periods with no out-of-bank flows if the stream water surface profile is sufficiently high.

(iii) Hydraulics—The stream’s hydraulic characteristics are determined by its **channel geometry**. Channel geometry parameters include bankfull width, bankfull depth, channel slope, flood plain slope, sinuosity, and the Manning’s n value. Hydraulic analysis can be done simply by using cross-sectional data and Manning’s equation, or by analysis of the stream’s water surface profile along a reach using the USACE HEC–RAS program. Simple stage-discharge data for a single cross section can be obtained with the use of the WinXSPRO program.

(3) Loss of function

Loss of function in riverine wetland systems is caused by channel incision, channel bank instability, flood control dikes, alteration of the flood plain surface, or other reasons.

(i) Channel incision—Riverine wetlands that have been altered due to channel incision are common throughout the country. Incision is caused by a range of activities including channel straightening, change in watershed conditions, and interruption of sediment transport. The channel’s capacity has increased to the point where flooding in the riverine wetland no longer occurs or the stream supported ground water table is too low to support wetland hydrology.

(ii) Channel bank instability—These wetlands have been altered by the loss of streambank stability. The channels often have hard, immovable beds which preclude grade loss. The banks typically have eroded because of the removal of riparian wetland vegetation due to clearing, grazing, channel straightening, flow augmentation, or watershed modifications. The bank erosion process converts riparian wetland zones to active channel.

(iii) Diked or leveed streams—These wetlands have been altered by the presence of dikes adjacent to the channel, preventing flood flows from entering the

flood plain. Typically, the original wetland hydrology was provided by these flood flows, and not by stream water surface profile induced ground water. Surface water from adjacent uplands is either diverted around the wetland or is transported through the flood plain, the dike, and into the channel through a conduit with a “flap gate.” The flood plain may have remnant flood plain features.

(iv) Flood plain alteration—Natural flood plains exhibit a variety of morphological features that support wetlands. Abandoned channels, scour features, natural levees, chutes, and oxbows are formed and maintained by the interaction between the stream and flood plain during out of bank flows. These features are **macrotopography** features. These features are commonly erased to increase the land’s productive capacity for agriculture. Surface ditches and buried drain conduits may be installed to move surface and ground water from the wetland into the stream channel.

Microtopography features are extremely valuable to riverine wetland function. They are created by surface flows, blowdown of trees, or the action of certain high shrink-swell soil types (gilagi microtopography). These features, by definition, are less than 6 inches in height or depth. These features are also commonly erased by changes of land use in the wetland.

(4) Restoration strategies

For the purpose of this discussion, the term active flood plain includes those flood plains that were active before historic stream corridor alterations, such as levee construction or channel incision.

The most comprehensive restoration is one which restores dynamic hydraulic and hydrologic connectivity of the stream to its flood plain. It must be recognized that a strict **restoration** of the stream corridor to historic conditions may be inappropriate. In many, if not most cases, the original stream watershed conditions no longer exist. Thus, the original stream hydrographs that formed the channel geometry found on old aerial photography and topographic maps would not provide long term dynamic equilibrium today. However, the channel can be provided a new geometric template under current hydrologic conditions which provides long-term stability and connectivity with its flood plain. The benefits to this approach are many. They include:

- increased diversity of wetland hydroperiod and regime
- minimum long-term maintenance of constructed features
- minimum management requirements
- natural cycling of plant communities' age and diversity
- maximum connectivity for aquatic organism passage, both laterally and longitudinally

Constructed features of the flood plain are limited to restoring or mimicking the original shape, size, and geometry of remnant flood plain features. These features include the natural levees, scour channels, abandoned oxbows, sloughs, and microtopography mentioned earlier. In the comprehensive restoration approach, these features are assumed to begin functioning dynamically after restoration and will adapt themselves in form by interaction with flood flows after the restoration is complete.

Where a comprehensive restoration of flood plain connectivity is not possible due to land ownership, economic, or other considerations, an attempt must be made to increase function by increasing flood plain hydroperiod, hydrologic regime, and connectivity, as much as possible. Partial breaching of levees, construction of flood plain features, and installation of water control structures and other measures can be accomplished. As the potential for complete dynamic restoration decreases, the required level of management and maintenance increases. Specific strategies for riverine wetland restorations based on the previous loss of function categories follows.

(i) Channel incision—There are three basic options to increase wetland function. The first concentrates on the flood plain wetland area with no attempt to restore the channel. The area must support wetland hydrology with surface runoff and ponding. Surface runoff from uplands and other flood plain areas is diverted and stored with structures to provide wetland hydrology. If water level is to be controlled, the means of control must be designed in accordance with CPS 587, Structure for Water Control.

The second alternative option is to raise the stream water surface profile by installing grade stabilization structures, decreasing the channel capacity by de-

creasing the width and/or depth, or both. It is critical to ensure that the upstream effects do not extend beyond the project boundary or to obtain easements for these effects. This option is most appropriate where the channel has incised in place, without channel straightening. The grade stabilization structures should be full-flow, open structures, spaced closely together to prevent excessive water surface profile drop between structures and designed in accordance with CPS 410, Grade Stabilization Structure. The drop is typically held to about 1 foot between structures. Careful attention is given to the downstream structure where the profile is returned to the incised channel. Interruption of sediment transport caused by the new structures can cause grade loss downstream of the project.

Installation of embankment dam grade stabilization structures on the stream channel should be considered an enhancement practice. Routing flows through a detention pool will alter the stream hydrograph and result in a change of HGM wetland type from riverine to depressional, with a resulting trade-off in wetland function. This installation usually results in higher operation and maintenance requirements.

The third alternative option is to perform a complete meander reconstruction of a new channel with the appropriate width, depth, slope, and sinuosity to restore horizontal connectivity with the flood plain wetlands. The services of a trained fluvial geomorphologist may be needed. Planning and design are accomplished in accordance with NEH, Parts 653 and 654.

(ii) Channel bank instability—In cases where no channel incision has occurred and wetland hydrology still exists, restoration focuses on reestablishing wetland vegetation. In many cases, livestock exclusion is all that is necessary. Soil bioengineering measures should be incorporated in accordance with CPS 580, Streambank and Shoreline Protection. Guidance can be found in NEH, Part 654.

(iii) Diked or leveed streams—A complete restoration would require removal of the dike. Often, it is cost prohibitive to completely remove the dike and properly dispose of the fill material. Usually, flood flows can be allowed onto the flood plain by breaching the dike in one or more locations. The areas of dike removal must be carefully considered. A breach at the downstream end of the diked area will allow backwa-

ter to enter the wetland and minimize the danger of high velocity floodwater flowing through the wetland. Internal wetland structures can be maintained for water level control using this approach. An additional breach at the upper end of the area will allow flood flows to pass through the system. This approach can be utilized to allow the stream system to maintain a natural dynamic wetland, with associated scour channels, natural levees, abandoned oxbows, and other flood plain features. Internal water level control structures are problematic using this approach, as they are subject to headwater flows through the flood plain.

A hydraulic analysis of the system is recommended when designing a headwater dike removal. The resulting change in the stream water surface profile at the up and downstream end of the project may create channel instability. Removal or breaching of the dike is often not possible because of land rights or off project effects. A restoration then must focus on using an alternate water source to mimic the original hydroperiod and hydrologic regime of the riverine system. Water is only available from precipitation and onsite and off-site surface runoff. Structural measures, such as dikes and water control structures, are usually required.

(iv) Altered flood plains—

Macrotopography replacement—Restoration and enhancement efforts should include replacing macrotopography features such as abandoned channels, oxbows, and scour channels. These features, as opposed to microtopography features, are greater than 6 inches in depth. Often, aerial photography and historical records can provide the location and extent of these features so they can be rebuilt to their original geometry. Otherwise, reference reaches of the same stream or similar streams can provide a template for restoration of these features. If the stream is still in hydraulic connection with the flood plain, it is important to construct flood plain features that are stable during flood flows. Figure 13–3 shows an example of macrotopography restoration in a riverine wetland.

Microtopography replacement—Microtopographic features are those that provide less than 6 inches in water depth. They experience frequent wetting and drying, and thus provide a dynamic range of habitats, both spatially and temporally, which many wetland plant and animal species depend upon. These features should be installed with varying depths, size, and spacing to provide a range of hydroperiod and hydrologic

regime. Figure 13–4 shows an example of natural microtopography created by tree blowdown. Figure 13–5 shows an example of restoration of gilgai microtopography.

(c) Slope wetland class

Slope wetlands occur where there is a discharge of ground water to the land surface. (USACE WRP DE–9). This is a deceptively simple definition which requires much further explanation.

(1) Geomorphic setting

Slope wetlands can be divided into two categories. Topographic slope wetlands occur in concave convergent positions on landscapes. Stratigraphic slope wetlands occur where the landscape geology creates anisotropic conditions that focus ground water to a point of discharge.

(i) Topographic slope wetlands—Concave landscape positions occur at the head end of watershed boundaries. Thus, topographic slope wetlands may be adjacent to and converge with riverine wetland systems. The dominant water source is ground water. The concave topography focuses ground water to a single low point on the landscape. If the ground water discharge exceeds the losses due to evapotranspiration from the land surface, a flowing spring develops. These wetlands can transition into riverine or depressional systems downslope.

These wetlands typically appear in a shape dictated by the convex shape of the landscape. The upper boundary may appear with a gradual change in plant community transitioning to hydrophytic. The lower end commonly exhibits spring flow which occurs permanently, or only at the peak of the hydroperiod. As stated earlier, these wetlands are commonly the beginning of a stream channel network. They may also transition into depressional, lacustrine, or estuarine fringe wetlands. The geomorphic setting and hydrodynamics of topographic slope wetlands are illustrated in figure 13–2.

(ii) Stratigraphic slope wetlands—An anisotropic condition is one in which the vertical hydraulic conductivity and horizontal hydraulic conductivity are not equal. In most cases, the lateral conductivity is greater than the vertical. These conditions are created by a layer of low permeability soil, or rock which has a very

low vertical hydraulic conductivity. These layers focus ground water flow to a point of surface outlet on the landscape. Usually, these wetlands are horizontal, shallow vertically, and have a sharp upper boundary. They lend themselves to the development of springs for use by humans or livestock. When compared to topographic slope wetlands, they usually have less vertical extent, and broader horizontal extent.

(2) Dominant water source

The dominant water source is ground water. Significant contributions may be from direct precipitation and surface runoff. It is important to note that the ground water source is direct precipitation. In some cases, the ground water recharge area of these systems can be determined from surface topography, and water budget studies can be made using precipitation and evapotranspiration data.

(3) Hydrodynamics

The dominant direction of movement is horizontal and unidirectional.

(4) Loss of function

The loss of slope wetland conditions is usually associated with the interception or sealing of the ground water source. This interception may be associated with changing land use to a cover which decreases the percolation of rainfall, such as urbanization. A change of use from rangeland to cropland may decrease the plant evapotranspiration enough to actually induce slope wetland conditions. This phenomenon occurs in "saline seeps," which are found in the northern High Plains and Intermountain Region of the United States, where rangeland has been converted to dryland wheat production. Compaction of slope wetland areas due to overgrazing may prevent water from reaching the surface. Poor grazing practices may also promote the growth of woody vegetation, which may have a higher evapotranspiration rate than the original herbaceous cover. A very common interception method is the installation of horizontal tile drains for the purpose of eliminating wetland conditions at the base of the slope adjacent to cropland. This method is especially effective in stratigraphic slope situations, where the interception can be focused directly on the confining rock layer. On flatter slopes, surface ditches have been used to intercept ground water flow and divert it elsewhere. The installation of spring developments for livestock or domestic water supply can alter wetland conditions.

(5) Restoration strategies

Restoration can be readily accomplished on sites where physical drainage measures have been installed. Removal, plugging, or filling of these tile drains or ditches is effective in restoration. On sites where watershed conditions have been changed, proper grazing management, brush control, or conservation tillage practices can reestablish wetland hydrology.

(d) Mineral soil flat wetland class

Mineral soil flat wetlands are most common on uplands between stream valleys (interfluves) and on extensive relic lake bottoms where the dominant water source is precipitation. Common hydrology analysis tools are water budget tools and scope and effect equations, when drainage systems have been installed. Mineral soil flats may transition into riverine, hillslope, and depressional wetlands.

(1) Geomorphic setting

Mineral soil flats are generally flat to very gently sloping, with few natural surface drainage features. They generally are formed in slowly permeable soils, which hold water close to the surface. They occur extensively in eastern North Dakota, South Dakota, Minnesota, Iowa, and on the coastal plain of the Southeastern United States.

(2) Dominant water source

The dominant water source is direct precipitation. They receive virtually no ground water discharge and very limited surface runoff. They commonly occur in humid climates where the evapotranspiration during the hydroperiod is much less than the rain or snowfall.

(3) Hydrodynamics

The water movement in mineral soil flats is mostly confined to vertical fluctuations. Precipitation is stored in shallow depressions on the surface until it can infiltrate into the soil. Downward percolation under the force of gravity discharges water into the water table, which is commonly perched. Upward flux caused by capillarity replaces water from the ground water (if available), which is lost through evapotranspiration.

(4) Loss of function

Vast areas of mineral flat wetlands in North America have been drained by buried tile drains or surface

ditches. This physical drainage is virtually the only method of converting mineral flats to nonwetland conditions. Converting the slow discharge of these original wetlands to point discharges from ditches and pipes has eliminated much of the original nutrient cycling function of these areas. The result has been an increase in dissolved nitrogen in the rivers and tributaries of the Mississippi River Basin. The flood attenuation function has also been decreased.

The coastal plain of the Eastern and Southern United States has large mineral flat wetland areas which were once native forest or savanna. These soils have a horizon, which serves as reservoir for precipitation during the wetland hydroperiod. Conversion of land to grazing can lead to severe compaction of the surface, which prevents rainfall from percolating into the soil. The water is lost to direct runoff, preventing the maintenance of wetland conditions.

(5) Restoration strategies

Effective restoration of drained mineral soil flats is commonly done economically by partial removal or plugging of the original drainage tiles or ditches. In most cases, little increase in function is realized by complete removal.

Restoration of hydrology due to surface compaction can be accomplished with grazing practices which increase soil tilth and root development. This can include precluding grazing during the wet period of the year when soil compacts readily. Other measures include physical ripping of the area or establishing vegetative cover (forest or herbaceous).

(e) Organic soil flat wetland class

Organic soil flats are similar to mineral soil flats. However, their elevation and topography are controlled by the vertical accumulation of organic matter. They are common in the North-central, Northeastern, and Southeastern United States.

(1) Geomorphic setting

Organic flats commonly occur on flat uplands between stream valleys (interfluves). They also commonly occur in large depressions, where organic accumulation has formed a flat surface. Organic flats occur in the unique situation where biomass from dead plants builds up faster than decomposition. **Anaerobic** con-

ditions caused by saturation slow or halt this decomposition.

(2) Dominant water source

The source of water is usually limited to direct precipitation. On the margins of organic flats in large depressions, ground water may be a significant water source.

(3) Hydrodynamics

Water movement is essentially vertical. Precipitation infiltrates into and percolates downward into the soil. Water moves out of the wetland by percolation into the ground water table and by overland flow when saturation occurs.

(4) Loss of function

Drained organic flats often provide extremely rich agricultural soils. Tile drainage, surface ditches, and bedding are frequently used to partially or completely drain these wetlands. While the carbon sequestration benefits of existing organic wetlands may be in equilibrium, drainage almost certainly causes aerobic decomposition, which releases organic carbon into the atmosphere. In addition, drained organic flat wetlands can experience **subsidence** when aerobic conditions cause a loss of organic soils. Instances of subsidence of several feet have occurred in extreme cases. Many threatened and endangered plant species exist only on these organic soils.

(5) Restoration strategies

Restoration will focus in removing the original drainage methods, similar to the treatment for mineral flats. In areas where large subsidence has occurred, the restoration of the original ground water level will result in large areas of open water where wet soil conditions occurred originally. The open water areas will not support the original wetland plant communities which provided the plant material to develop organic soils. However, any saturated conditions will halt further loss of organic soil.

(f) Lacustrine fringe wetland class

These wetlands exist in a zone between nonwetland and deepwater areas adjacent to freshwater water bodies (lakes) which are generally larger than 20 surface acres in size. On the landward side, they may transition to slope wetlands. Large prairie potholes and playa lakes can be considered to maintain lacustrine fringe wetlands along their shorelines.

(1) Geomorphic setting

The lacustrine fringe is a gently sloping transition area into the lake.

(2) Dominant water source

The dominant water source is the lake's water. The water moves into the fringe as ground water maintained by the lake level or surface overflow as the lake level rises. Additional water sources can be overland flow from uplands, direct precipitation, and ground water discharge from upland sources.

(3) Hydrodynamics

The movement of water is bidirectional and horizontal. Lake level rises move surface and ground water into the wetland, and lake level lowering causes the reverse.

(4) Loss of function

Conversion of lacustrine fringe wetlands, when done, is usually by filling with mineral soil for the purpose of increasing available land for agricultural production or development.

(5) Restoration strategies

Restoration must be accomplished by lowering the wetland surface to its flood plain original level relative to the lake level. This is expensive and is not commonly done.

(g) Estuarine fringe wetland class**(1) Geomorphic setting**

Also called tidal fringe wetlands, this type exists along coasts and estuaries which are under the influence of tides. They transition into riverine wetlands as the tidal currents diminish upstream. They may also transition into slope wetlands at the horizontal boundary of the estuary.

(2) Dominant water source

The dominant water source is tidal fresh or brackish water controlled by tidal action. Additional water sources can be precipitation, streamflow, and ground water recharge.

(3) Hydrodynamics

Water movement is essentially bidirectional and horizontal as tidal action moves water inland and seaward with tidal fluctuations. The movement is bidirectional

near sea level and transitions to unidirectional inland, as the dynamics are dominated by outflow from the adjacent river.

(4) Loss of function

Estuaries can be physically converted by filling, or conversion can be initiated by altering the interaction between freshwater, saltwater, and wetland vegetation. In the extensive estuarine wetlands of Louisiana and Mississippi, interior marshes are freshwater and maintain their base level by the build-up of organic soil due to the decomposition of freshwater plants. As channels for boat access are cut through these freshwater marshes, tides can push saltwater deep into these freshwater areas and cause the plants to die. Loss of this plant cover leads to loss of organic build-up and leaves the original soils exposed to erosion.

Saltwater marshes receive seawater by the direct action of tidal flows. These areas are commonly altered by the installation of dikes, which prevent high tide stages from accessing the wetland.

In both fresh and saltwater marshes, tidal flows enter and leave the wetland through discrete tidal channels. The natural size, shape, and slope of these channels were determined by the complex interactions between volume of flow, tide cycles, and interaction with freshwater from inland. Freshwater marsh wetland improvement is usually concerned with blocking man-made channels.

(5) Restoration strategies

In the case of saltwater intrusion into freshwater marshes, restoration can be accomplished effectively by blocking channels which allow tidal saltwater. Exposed eroding soils, whether organic or mineral, can be revegetated to prevent further loss. If subsidence due to decomposition of organic soil has occurred, the restored area will have a deeper hydrologic regime than the original. Selection of plant species must take this into account.

Saltwater marshes with dikes can be restored by careful removal of dike sections and the re-creation or restoration of an inlet channel. Saltwater marsh improvement is especially complex because it focuses on the analysis of the inlet channel dynamics. A detailed discussion of saltwater marsh tidal flows is found in 650.1304(a)(3)(i).

Figure 13-1 HGM wetland types

(a) Concave slope wetland



(b) Concave slope wetland— Idaho



(c) Stratigraphic slope wetland— Kansas



(d) Depressional wetland—California vernal pool



(e) Mineral soil flat—Minnesota

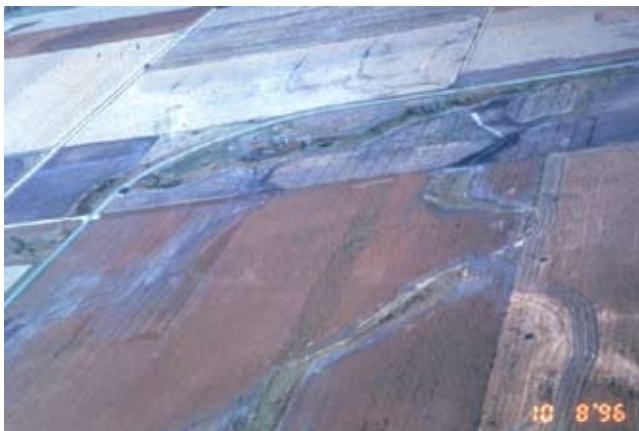

(f) Riverine—Colorado



Figure 13-1 HGM wetland types—Continued

(g) Depressional—High Plains playa—Texas



(Photo by Dr. Loren Smith)

(h) Depressional—Prairie potholes—South Dakota



(i) Estuarine fringe wetland—Connecticut



(j) Riverine wetlands—Tennessee



Figure 13-1 HGM wetland types—Continued

(k) Estuarine fringe—Oregon



(l) Lacustrine fringe wetland—Wyoming

**Figure 13-2** Hydrodynamics of HGM wetland classes

(a) Depressional wetland with perched water table—playas

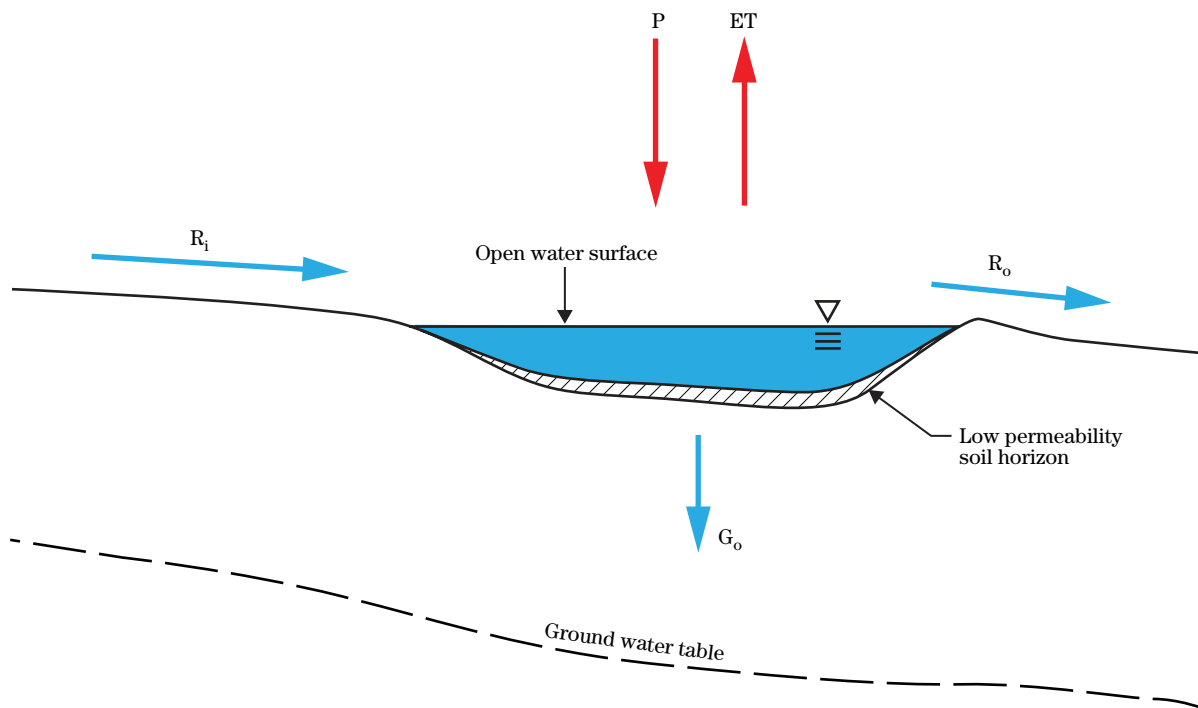

Figure 13-2 Hydrodynamics of HGM wetland classes—Continued

(b) Depressional wetland with ground water influence—prairie potholes

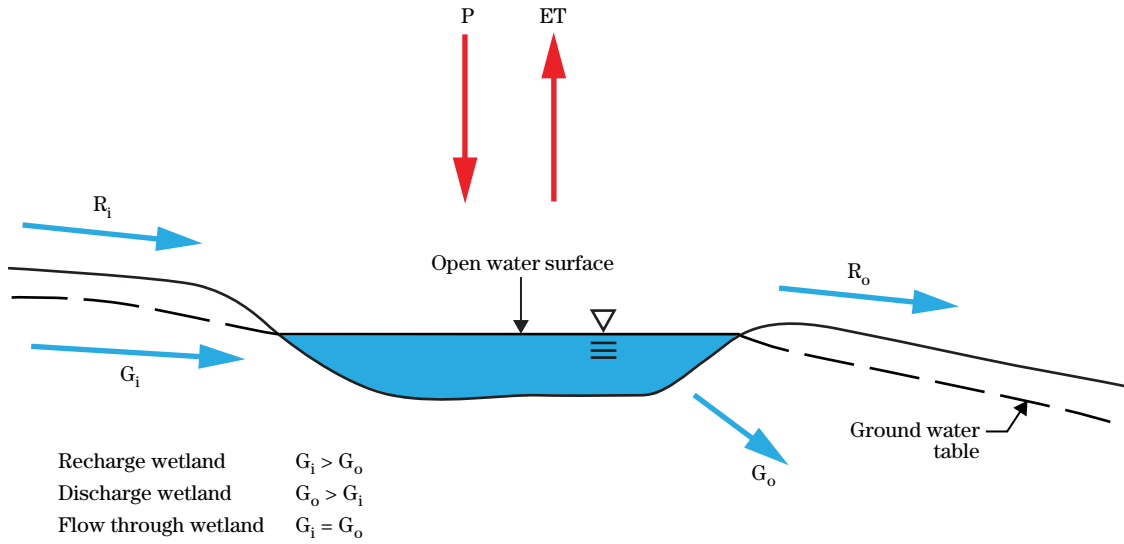

Figure 13-2 Hydrodynamics of HGM wetland classes—Continued

(c) Topographic slope wetland—plan view

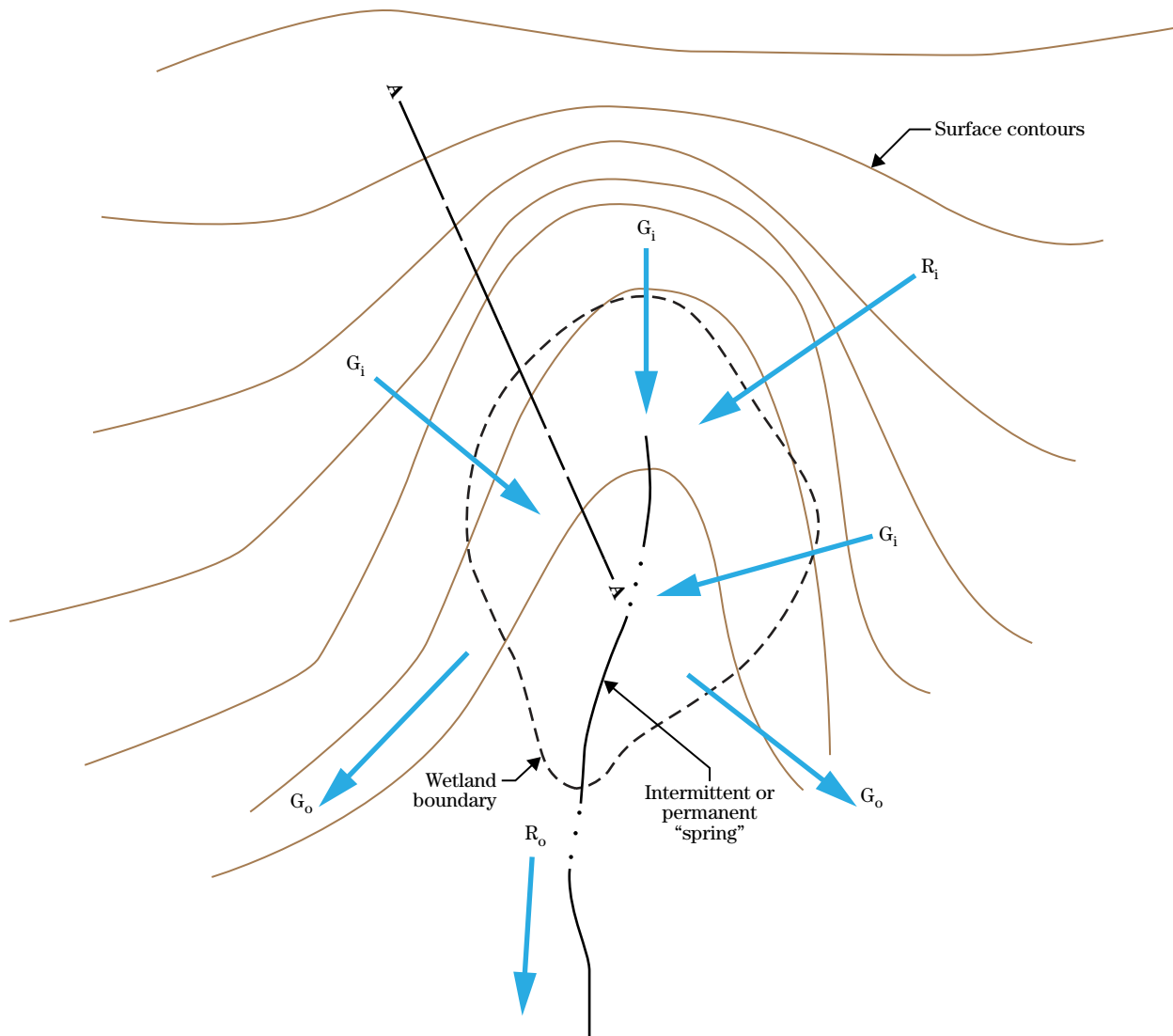
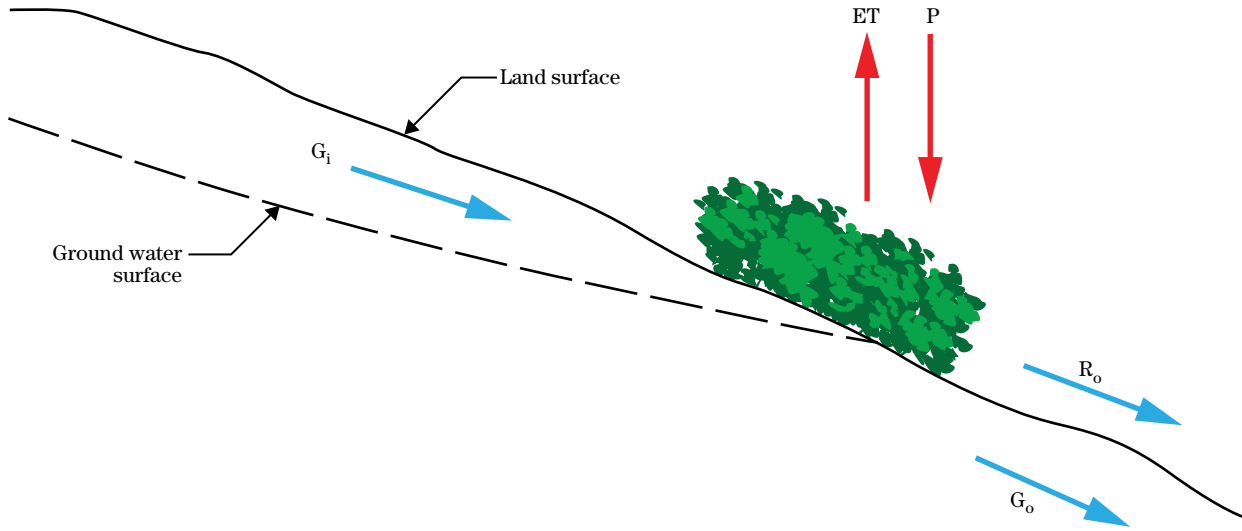

Figure 13-2 Hydrodynamics of HGM wetland classes—Continued

(d) Topographic slope wetland—cross section



(e) Stratigraphic slope wetland—plan view

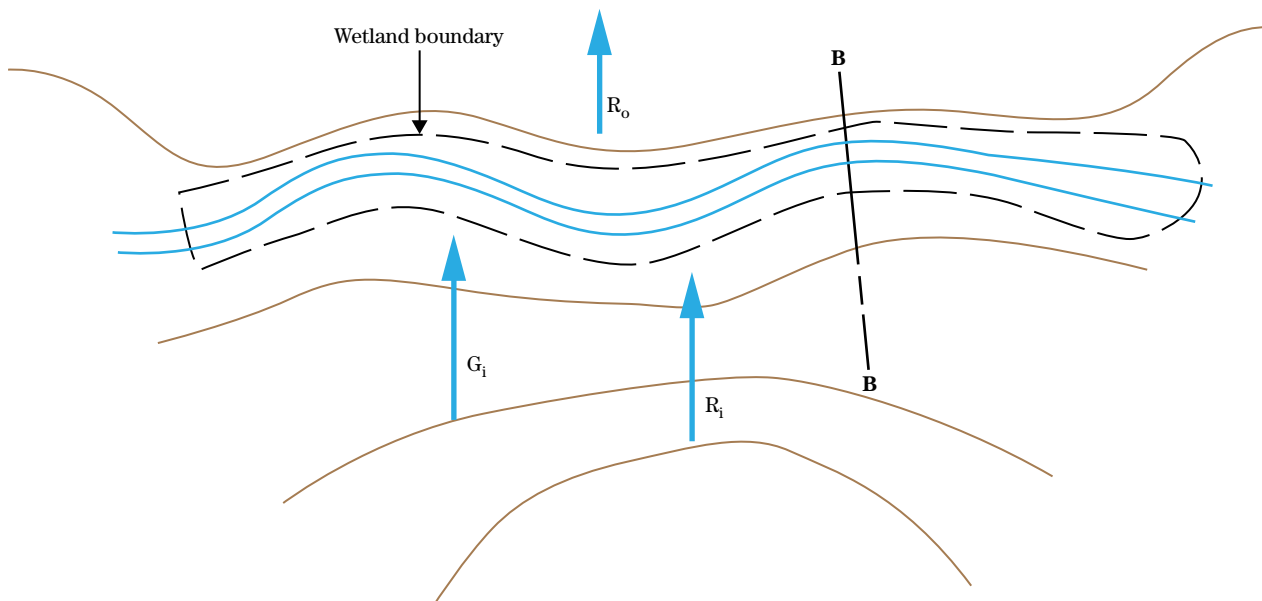
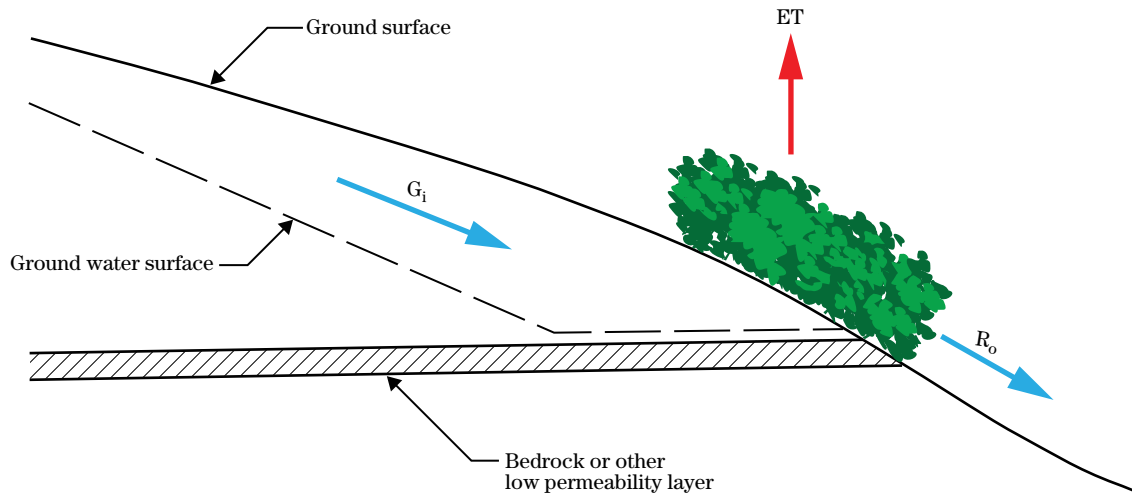

Figure 13-2 Hydrodynamics of HGM wetland classes—Continued

(f) Stratigraphic slope wetland—cross section



(g) Mineral soil flat wetland

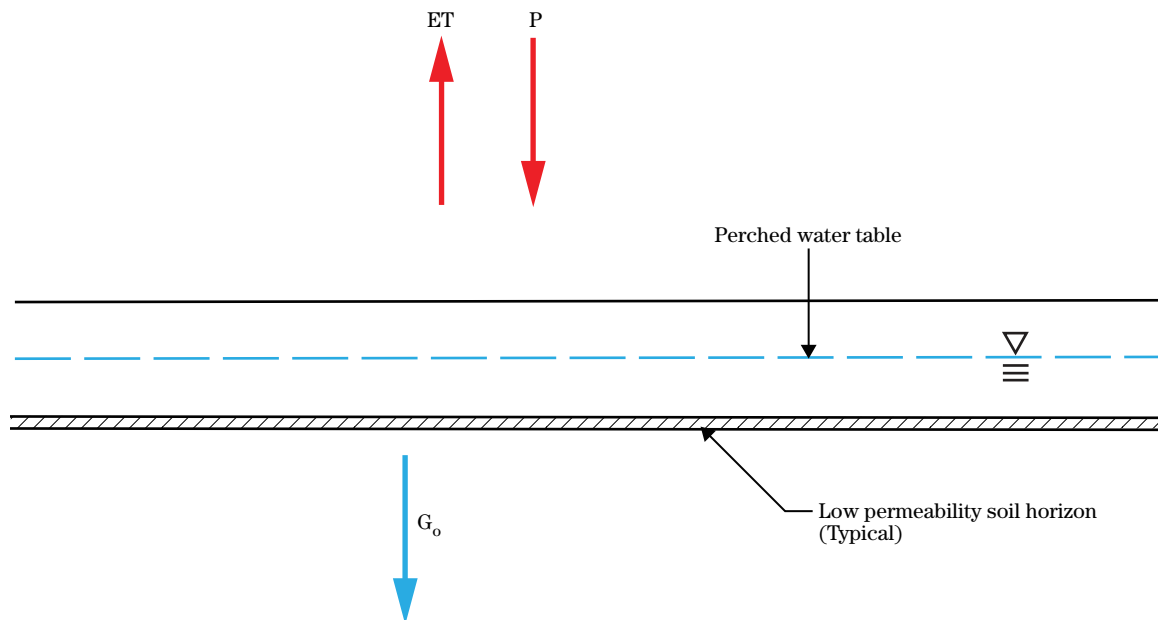

Figure 13–3 Restoration of flood plain macrotopography**Figure 13–4** Microtopography feature created by a blown down tree**Figure 13–5** Restoration of microtopography on gilgai soils on a riverine wetland

650.1302 Wetland processes and characteristics

(a) Physical processes

As stated in the previous section, the fundamental physical factors that control wetland functions are geomorphic setting, water source, and hydrodynamics. Each of these three factors must be defined in the planning stage. Decisions can then be made regarding the need and appropriateness of restoring, enhancing, or creating the functions of these factors.

(1) Geomorphic setting

Geomorphic setting is the landform of a wetland, the geologic process which created it, and its position on the landscape. The geomorphic setting defines the seven classes in the HGM system. Planning for restoration should focus especially on working within this setting. Wetland enhancement and creation projects can be planned to mimic features of a particular setting to improve certain functions.

Geomorphic setting can be dynamic in nature. For instance, a riverine wetland on a broad flood plain flat can be restored by excavation to create an original abandoned oxbow feature. However, the original riverine setting had a shallow stream that flooded every other year. If the channel is now incised to the point where it floods only every 10 years, the geomorphic setting of the feature has changed, with subsequent changes in its hydrology. Another example is a topographic slope wetland where erosion has advanced a channel through the elevation where ground water reaches the surface. The hillslope wetland may move laterally away from the new channel, and the original area is now evolving into a riverine HGM type.

(2) Dominant water source

A wetland's hydroperiod refers to the timing, duration, and depth of saturation and inundation. This hydroperiod is controlled by a dominant source of water. Water sources include direct precipitation, surface runoff, ground water inflow, stream flood flows, lake overflow, and tidal fluctuations. Most wetlands also have one or more secondary water sources. Restorations should focus on reestablishing this dominant water source. If an enhancement is done with

water sources which were not the original dominant water source, the hydroperiod may be changed. With different water sources, water chemistry and temperature differences may also influence plant, animal, and microbial communities, with effects on wetland functions.

For example, a depressional wetland may have originally been supplied with water from ground water inflow, providing a long-term steady water level in the wetland. If the restoration plan is to supply water by diverting more surface runoff, the wetland will show more fluctuation, more extremes between wet and dry periods, and will receive water somewhat earlier than originally.

(3) Hydrodynamics

Hydrodynamics refers to the direction of flow and strength of water movement within the wetland. These factors have a profound effect on the species and composition of vegetation, the morphology and composition of wetland soils, and the quality of the water in the wetland. Directions are referred as vertical or horizontal and unidirectional or bidirectional. In addition, wetlands are defined as discharge or recharge wetlands with respect to ground water flow. Project planning should define the wetlands current and restored hydrodynamics.

(4) Common physical considerations

(i) Sedimentation in depressional wetlands—Sedimentation is a temporary condition which typically results when watershed conditions change to deliver sediment to a wetland faster than the rate of hydric soil formation. The wetland suffers a loss of capacity and a shortened hydroperiod. In addition, sediment changes the physical and chemical characteristics of the wetland soil, with corresponding changes to the vegetation and habitat characteristics. Restoration can be accomplished by intercepting the sediment with soil conservation practices on the watershed, physically removing the sediment down to the original hydric soil layer, increasing the depth of the depression with water control structures, or combinations of these practices. Care should be exercised when removing sediment. The original surface layer of wetland soils is usually rich in organic material and other nutrients. Excavation down to a dense low permeability soil layer may remove this surface layer, but with a negative impact on the wetlands ability to establish a healthy plant and animal community.

(ii) Aerobic decomposition of organic soils—Organic soils form when anaerobic conditions prohibit the breakdown of organic matter at the same rate as its formation. Large amounts of organic carbon exist in organic soil flat wetlands. When drained, aerobic breakdown of these soils releases large amounts of carbon dioxide into the atmosphere. In these cases, the saturated condition must be restored to its original condition. Increasing the depth of inundation beyond its original level may prevent the growth of new plant material, thus ceasing or minimizing the carbon sequestration attributes of the wetland.

(iii) Stream modification in riverine systems—Modifications to a stream's channel geometry, hydraulic characteristics, and flow have direct effects to the adjacent riverine wetland through changes to the volume, timing, and duration of the water supply. Water is delivered to riverine systems as both surface and ground water. Changes to the stream's cross section, location, or flows can affect both the ground water and surface water delivery.

(b) Chemical processes

(1) Redox potential

Redox potential is a measure of the potential electron exchange in the soil. When wetland soils become saturated, the diffusion of free oxygen through the soils is drastically reduced, and if organic matter is present for microbial consumption, anaerobic conditions will develop. Under anaerobic conditions, various oxidized ions (such as NO_3^- , Mn^{+4} , Fe^{+3} , SO_4^-) gain additional electrons and are changed to reduced forms. This process of gaining electrons is called reduction and is mainly due to microbial activity. In soils, redox potential and pH are interrelated. Under reduced conditions, soil acidity may be temporarily consumed, and the pH of the reduced soil may tend toward a more neutral pH. If the wetland soil is drained, it becomes oxidized and will generally revert to the more acid condition.

(2) Nitrogen

Wetlands are very important in cycling nitrogen. As the dissolved nitrogen in the water passes through a wetland, much of it is captured and transformed by microbes. Plants take up nitrogen as they grow and release nitrogen as they decompose. Because nitrogen may be the most limiting nutrient for plant growth in estuarine systems, excess nitrogen can contribute to

eutrophication or rapid plant growth. Nitrogen can leave a wetland with the water outflow. Because of the anaerobic conditions of wetland soils, much of the nitrogen becomes a gas and escapes to the atmosphere. The process of nitrogen loss is called denitrification.

(3) Iron and manganese

The reduced forms of iron (Fe^{+2}), and manganese (Mn^{+2}) in wetland soils are more soluble and, therefore, available to organisms. Reduced iron in wetland soils gives the soil a gray to green or bluish green color, with the green or bluish green indicating the most reduced cases. In aerobic zones, bacteria promote the oxidation of iron and manganese to more insoluble states.

(4) Sulfur

Oxidized sulfur can enter wetlands through precipitation and runoff. As the sulfur is reduced (S^-), it can form hydrogen sulfide gas (H_2S) that has a “rotten egg” smell. Sulfides and iron combine to form ferrous sulfide, which makes some wetland soils black. Oxidation of reduced sulfur in wetlands can create extremely acid conditions.

(5) Carbon

Carbon dioxide gas is converted into organic carbon by plants during photosynthesis. As organic matter decomposes in wetlands, some of the carbon is transformed into acids, alcohols, and methane gas.

(6) Phosphorus

Most phosphorus is transported to wetlands with sediments, although in extremely high concentrations has been found to be soluble. In freshwater wetlands, it is the most limiting nutrient for plant growth, thus excess phosphorus can contribute to eutrophication. Phosphorus taken up by the plants is released as plant debris decomposes. In anaerobic conditions, phosphorus is more likely to form soluble compounds and can be removed from the wetland with the water.

(7) Salinity

Depressional wetlands with ground water influence are either “recharge,” “discharge,” or “flow-through” wetlands. Recharge wetlands gain more ground water than they lose. The difference is made up with evapotranspiration and surface outflow. Discharge wetlands lose more ground water than they gain. Their dominant water sources are surface runoff and precipitation. Flow-through wetlands have a rough net balance

in ground water inflow and outflow. If there are sufficient salts available in the geologic substrate, recharge wetlands tend to be more saline than discharge wetlands if their dominant loss of water is evapotranspiration. Water uptake by plants and surface evapotranspiration leaves mineral salts behind. Discharge wetlands, which receive surface water, tend to have lower salt content. In some cases, changing the wetland’s hydrodynamics by increasing or decreasing the surface water supply can alter the salinity level. The surface water component of the water budget can be changed by diverting surface water, changing the watershed vegetation or management, or other methods.

Large areas of the United States have a surface geology dominated by marine shales, which hold sodium in the rock matrix by electrochemical attraction. As water moves downward into these shales, the highly soluble sodium ions move with the water, and the low permeability of the shales forces this solution to move laterally to a point of discharge on the land surface. As water evaporates, the sodium ions recombine with sulfate or chloride ions to leave salts behind on the surface. These areas are called “saline seeps.” Changes in vegetative cover in the ground water recharge area can have a very direct effect on the amount of water available to these seeps.

(c) Biological processes

(1) Microbes

Microbes play a major role in the transformation of substances critical to all life on earth. In wetlands, the population of microbes in the substrate shifts from aerobic species near the surface to anaerobic species as depth increases. Aerobic microbes also continue to function in the thin, oxygen-rich zone called the rhizosphere surrounding the roots of wetlands vegetation and at the water surface. Mycorrhizial fungi are beneficial microbes that facilitate nutrient uptake, reduce stress, enhance salt and contaminant tolerance, and enhance the initial survival and growth of wetland plants.

(2) Vegetation

Wetland vegetation may be described as floating, emergent, submergent, herbaceous, or woody. Vegetation creates structure within the wetland (vegetation strata and aquatic zones) that serve as shelter and breeding sites for animals (fig. 13–6). Wetland

plants also transport oxygen from the atmosphere, through the stem, and into the roots that grow in anaerobic conditions. Wetland plants, along with microbes, are the most basic and critical components in wetlands. Plants use solar energy to produce organic carbon, which serves as the food source for the entire biotic community, including animals and microbes. Radial oxygen loss from the roots creates an oxidized zone in the soil immediately surrounding them. The value of microbes to vegetation is described. Wetland vegetation also traps sediment and removes nutrients and pollutants from the water column and soil. Wetland plants produce more biomass (stored carbon) per acre than any other species group and export huge quantities of detritus to aquatic systems, providing direct benefits for food web support.

(3) Animals

Wetlands provide water, food, shelter, breeding, and nesting sites for many animals including many rare and declining, threatened, and endangered species. Diverse assemblages of micro and macro invertebrates, fish, amphibians, reptiles, birds, and mammals are found in, and are dependant upon, wetland systems. As individuals, animals influence small scale processes within wetlands, whereas a population of individuals may exact significant, large-scale influences on wetland dynamics and function. In addition to wetland dependant animals, many species typically not recognized as wetland residents spend some part of their life cycle or fulfill daily requirements within wetlands.

Figure 13-6 Wetland vegetation has a role in many wetland functions (Marsh Pepper)



650.1303 Pre-implementation wetland planning

The nine steps of planning include the implementation phase, of which design and monitoring are a part. This section includes the seven steps of the process up to implementation.

(a) Planning step 1—Define the problem

The first step in wetland planning which is often overlooked is to define the problem. A helpful tool is a functional assessment model for the HGM wetland type. This model will have a list of appropriate functions for this HGM type. The problem definition then becomes an exercise of determining which of the current functions is lacking or needs improvement. Use of this tool can prevent the misallocation of time and resources in implementing a project which cannot perform properly.

(b) Planning step 2—Determine objectives

The objectives and goals of any wetland project must be defined in the early stages of the planning process. These goals will reflect the desire to restore, enhance, or create one or more of the wetland functions in the local functional assessment. Examples of wetland functions are described in table 13-1. Planning should be oriented toward restoration, enhancement, or creation of an ecologically, biologically, and hydrologically functional system. Objectives should encompass regional and hydrologic unit priorities whenever possible. An understanding of how the wetland functioned in its natural, undisturbed condition should also be considered. Individual wetlands are part of larger wetland complexes that must be addressed in planning and site selection.

In siting target areas to achieve desired objectives, inventories should address both quantity and quality of resources and should locate and identify existing, altered, or lost wetlands. For example, target groups of wildlife or fish or target functions, such as water storage or sediment control, can be more readily achieved if past resources and functions are known.

Table 13–1 Common wetland functions and processes

Function	Description	Function interaction	Planning/design considerations
<i>Physical processes</i>			
Dynamic surface water storage	The capacity of a wetland to detain moving water from surface runoff for a short duration (flood routing)	In addition to downstream flood reduction, this function can improve water quality through retention of sediments, improved nutrient cycling, and improved quality of wildlife habitat	In riverine systems, planning for increased floodwater storage must be done in the context of the stream corridor. Vegetation, channel geometry, sediment transport, and planned structural components interact during surface runoff events. In depressional systems, floodwater storage must account for sediment accumulation
Long-term surface water storage	The capacity of a wetland to retain surface water for long durations	Long-term storage increases the wetland hydroperiod, with consequent benefits to vegetation, habitat, and nutrient cycling	Water storage can be improved by changing other factors in the water budget such as hydraulic conductivity, volume of inflow, plant transpiration, or available wetland storage volume. Operating a wetland at its maximum depth past its hydroperiod decreases available surface water storage
Subsurface storage of water	The availability of storage for water beneath the wetland surface	Subsurface water storage increases the hydroperiod, provides water to plants through dry periods, and increases the potential for anaerobic nutrient cycling	Over compaction of wetland substrate or removal of highly organic, low-density sediments can decrease the available pore space for storage of water. Maintaining a wetland at its maximum storage capacity outside the hydroperiod decreases available subsurface water storage
<i>Chemical processes</i>			
Removal of imported elements and compounds	A wetland's ability to remove delivered nutrients, elements and compounds, and contaminants	The wetland serves as interceptor of material delivered from incoming water sources. The result can be an increase in water quality in the wetland, as well as in water delivered from the wetland, with consequent improvement in vegetation and habitat both onsite and offsite	Wetland restoration, enhancement, or creation should not be used to treat specific point source pollutants. Use the Constructed Wetland Conservation Practice Standard in these cases. Nonpoint source runoff treatment should consider the need to remove a build-up of phosphorous or other mineral elements by plant harvesting or sediment removal

Table 13–1 Common wetland functions and processes—Continued

Function	Description	Function interaction	Planning/design considerations
<i>Chemical processes—Continued</i>			
Retention of particulates	The deposition and retention of inorganic and organic particulates from the water column, primarily through physical processes	Sediment and organic solids can be suspended by water entering the wetland that has sufficient tractive stress to entrain these materials. Velocity reduction due to static surface water in the wetland, or dense vegetation causes deposition. The quality of water delivered from the wetland is improved, and deposition is prevented from impairing downstream or offsite areas	The long-term accumulation of sediment must be considered for its effects on wetland function. Riverine restorations can be designed to cycle sediment into and out of the stream corridor, if planned to function dynamically. Vegetative functions may suffer because of sediment. Watershed treatment of upland drainage areas should be considered for sediment reduction. Depressional wetlands that capture sediment can be designed to function dynamically with sediment deposition as their size and shape adapts to increased deposition
<i>Biological processes</i>			
Maintain characteristic plant community	Species composition and physical characteristics of living plant biomass	Species composition and structure, regeneration, canopy cover, density of all vegetation, and basal area of trees have a direct effect on wildlife habitat, sediment deposition, floodwater storage, transpiration, nutrient cycling, and other functions	The planned wetland plant community must be able to function with the planned hydroperiod, water depths, management, structure operation, and habitat needs. Vegetation slows water velocity, takes up nutrients, provides cover, and a host of other factors. Methods of establishment, cost, required maintenance, and invasive species competition must be taken into account
Maintain spatial structure of habitat	The capacity of a wetland to support animal populations and guilds by providing heterogeneous habitats	The microtopography and macrotopography required to provide hydrologic diversity go hand in hand with creating a heterogeneous plant community which provide diverse habitats	The plan should provide for diversity of age and strata, horizontal and vertical structure, patchiness, and canopy gaps, which are matched with varying water durations and depths to provide a self-sustaining system. Microtopography usually provides an increase in this function

Table 13–1 Common wetland functions and processes—Continued

Function	Description	Function interaction	Planning/design considerations
<i>Biological processes—Continued</i>			
Maintain interspersion and connectivity	The capacity of a wetland to permit aquatic organisms to enter and leave the wetland via permanent or ephemeral surface channels, overbank flow, or unconfined hyporheic aquifers. The capacity of a wetland to permit access of terrestrial or aerial organisms to contiguous areas of food and cover	Increase in function of dynamic and long-term surface water storage provides increased connectivity to adjacent wetlands and streams for aquatic organisms. Increase of microtopographic complexity provides diverse hydrologic and vegetative conditions. Increase of spatial structure of habitat also provides increased connectivity	The physical substrate (land surface) of a wetland can provide the requisite conditions for a vegetative community, which provides connectivity. The planning and design of structures should consider provision for passage of aquatic and terrestrial organisms. Specific fish and herpetofauna structures can be considered
Maintain distribution and abundance of Invertebrates	The capacity of a wetland to maintain characteristic density and spatial distribution of invertebrates (aquatic, semiaquatic, and terrestrial)	Hydrologic, vegetative, and soil condition factors combine to provide conditions which improve the abundance of invertebrates	Wetland soil, decomposing leaf litter and coarse woody debris, and diverse aquatic water depths all contribute to an increase in this function. Microtopography usually provides an increase in this function
Maintain distribution and abundance of vertebrates	The capacity of a wetland to maintain characteristic density and distribution of vertebrates (aquatic, semiaquatic, and terrestrial)	Fish, birds, herpetofauna, and mammals use wetlands for part or all of their life cycle. The wetland vegetation, hydrology, and physical substrate relate directly to the quality of this function	Each wetland type and location must be carefully evaluated for the needs of local vertebrates. Fish and other aquatic organism passage may be a critical need. Waterfowl nesting and rearing are common concerns. Aquatic mammals such as river otters may need consideration. The design must consider the needs and challenges of mammals such as beaver, muskrat, and nutria
Rare and declining habitat	Vernal pools, high plains playas, wet savannas, prairie potholes, pocosins, and other habitats are either a rare habitat type or have been degraded more than other types	Diversity in habitat types across landscapes creates more opportunities for plants and wildlife. The rarity of certain habitats decreases these opportunities. Habitat loss is responsible for 85% of the imperiled plant and animals in the U.S. Restoration of rare and declining habitats could significantly alleviate further degradation of these species	The importance of specific wetland types will vary by region and state. Design wetlands to mimic the hydrology and ground surface microtopography of undisturbed habitats of the kind being restored. Replication of vegetation by specific species will be critical to this function

Sources of information that should be reviewed include the USFWS National Wetland Inventory maps, state wetland inventory maps (NRCS), U.S. Geological Survey (USGS) Topographic Quadrangle maps, geographical information system (GIS) data from Federal and state agencies, and wetland status and trend information from various agencies and groups (USFWS (<http://www.fws.gov/nwi>)). Historical aerial photography, such as Farm Service Agency (FSA) crop compliance photography and county soil survey information, can be useful in identifying hydric soils, drained wetlands, and various wetland types that may be difficult to detect otherwise. Flood plain elevations can often be determined from sources such as the Federal Emergency Management Agency (FEMA). Land user input may be the best source of information for assessing prior hydrologic conditions, the value of the lost wetland functions, and the feasibility of restoration or creation. By combining information from various sources, preexisting hydrology and existing drainage systems can be analyzed and documented on a restorable wetland site.

Landscape ecology offers a means of looking at the landscape comprehensively to determine the consequences of wetland restoration, enhancement, or creation. An understanding of how a landscape, composed of diverse ecosystems, is structured, how it functions, and how it changes, allows issues, such as habitat fragmentation and biodiversity, to be addressed in planning. More information regarding this ecological planning approach can be obtained from the journal *Landscape Ecology*, published by Springer Science+Business Media B.V., as well as other journals and publications. A key factor in the landscape scale approach to planning and design is that wetlands are part of an interconnected landscape of ecosystems of which humans are an integral component.

In general, restoring degraded wetlands within a complex of existing wetlands will have the greatest chance of success. This is because there is a greater chance of preexisting hydrologic soil conditions, better biological conditions such as seed-containing soils, and faunal recovery possibilities from adjacent areas. Wetland enhancement may be considered to improve wetland functions and values for a specific suite of species. Planners should assess the effects of targeted enhancement on the wetland's other functions and values. Wetland creation may involve such constraints as poorly suited soils, insufficient water supply, and lack

of desired plant material, rendering the process more difficult and expensive. For sites where conditions for wetland creation are suitable, features such as aspect, depth, dominant vegetation, sediment and detrital loading, light and wind exposure should be considered, as they are important in shaping an individual wetland's thermal, nutrient, hydrologic, and chemical dynamics, which strongly influence a wetland's resultant floral and faunal assemblages.

When investigating wetland functions, the planner should consider regional, watershed, and decision-maker objectives in setting priorities for restoration, enhancement, or creation. Table 13-1 lists 11 commonly considered functions, three wetland processes, and provides descriptions, some interactions between functions, and planning/design considerations for each. This list is not all-inclusive. Examples of multifunctional wetlands are shown in figure 13-7.

(c) Planning step 3—Resource inventory Planning step 4—Data analysis

Data collection and analysis is the first phase of site evaluation in planning a wetland project. The data collection and analysis done in these steps need not be to the level necessary for engineering design. However, design data may be collected and analyzed during the planning phase for future use. The information obtained is often used to determine feasibility of the project. The necessary data should be collected as early as possible in the planning process. The level of data collection will depend on the complexity of the proposed project.

As a general guideline, the following items should always be obtained during planning:

- soils map, with physical and engineering interpretations—Web Soil Survey or published soil survey. It may be appropriate to perform onsite investigations during this phase to determine soil texture, measure hydraulic conductivities, conduct geologic investigations, test for nutrients, pH, salinity, and contaminants, determine water holding capacity, and perform engineering analysis.
- hydrologic data—as appropriate, obtain enough information to determine the feasibility of project alternatives. This may include drainage area,

Figure 13-7 Wetland functions and values

(a) Dynamic surface water storage



(b) Removal of imported elements and compounds



(c) Maintain distribution and abundance of vertebrates

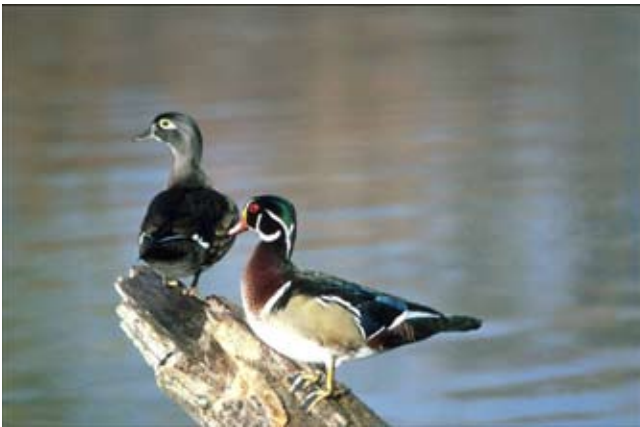

(d) Values—esthetic quality and open space



(including hydrologic soil group and land use and cover information), climate data (including WETS table), and stream records. In some cases, this is the step where complex hydrologic analysis is required. This may include runoff hydrographs, stream hydrographs and duration curves, evapotranspiration studies, and ground water investigations. An evaluation of the drainage area should be made that includes current soil erosion rates, sources of point and nonpoint pollution, and potential changes of land use which would affect the function of the project.

- project boundaries—in most cases, the selection of project boundaries can be based on the boundary of the landscape position which supports the HGM wetland class present; for example, a riverine wetland should ideally contain the active flood plain along a stream reach along one or both sides of the channel.
 - wetland determination for current and former wetlands—this should be done according to the three-factor approach of wetland hydrology, hydric soil, and hydrophytic vegetation used in the Wetlands Research Program Technical Report Y-87-1, Corps of Engineers Wetland Delineation Manual (COE 87M) and regional supplements; however, the level of detail used for delineations is usually not necessary.
 - existing drainage systems, including tile lines, drainage ditches, road ditches, culverts, and any other surface and subsurface features, affecting the direction of movement and quantity of water delivered to the project site
 - aerial photographs, USGS topographic maps, or GIS layers that include orthophotography, digital elevation model, and soils information
 - Federal, state, and local regulations that apply to the site
 - information required in the area to perform NEPA evaluation, including threatened and endangered species, and cultural resources
 - location of all utilities, roads, and other easements
- survey landscape context to determine landscape corridors that link habitat areas such as stream zones, ephemeral wet areas, woodlots, and others
 - detailed topographic surveys and/or cross section and profile surveys
 - vegetative surveys, including elevations and species noted in the area
 - fish and wildlife habitat evaluations, including the habitat needs for nesting, rearing, breeding, spawning, and other activities throughout their life cycle; this should include the connectivity requirements between the wetland and streams, uplands, or other landscape positions; this has a direct effect on the planned wetland components, hydroperiod, and hydrologic regime
 - landscape use and aesthetic quality evaluations
 - water quality data

More complex projects may require additional information such as a complete ecological or economic analysis. Intensity of the analysis should be commensurate with project complexity. More intensive evaluation normally is needed on wetland creation projects than on restorations or enhancements.

Large projects may have the potential to involve multiple landowners or units of government. Small projects may have the potential to become incorporated with existing or planned adjacent wetland projects. The resource inventory phase should include information necessary to make planning alternatives that utilize this potential. This may be as simple as discussing these possibilities with landowners and documenting the results. Or, it may involve researching the needed easements, permits, or studies required to satisfy the requirements of a drainage district, levee district, or state and Federal agencies.

Following is additional discussion of some of the items to be considered.

(1) Soils

Soils at the site of the proposed wetland must be assessed for overall suitability. Water holding capabilities are influenced by soil texture, organic matter content, and drainable porosity. Clays and loams generally retain moisture through capillary forces higher in the

Other data needed depending on wetland HGM type and planned functions may include:

soil profile than sands and sandy loams. The coarse textured soils may result in having “drier” plant communities, depending on water level. The soil’s suitability to support the planned plant community should be evaluated. The Web Soil Survey or published soil survey may provide physical and chemical interpretations for wetland vegetation.

The suitability of soils for construction should be evaluated during a geologic investigation. This includes logging in accordance with the Unified Soil Classification System (USCS) and may include collection of undisturbed samples for analysis of strength, consolidation, settlement, erodibility, and permeability. If there is the potential for soil dispersion, this analysis should be included, as well. Potential borrow sites (on or offsite), as well as structure foundations should be investigated.

During the site evaluation of the soils, any suspected topsoil contaminants should be analyzed. Often, this will require a soils test performed by the state agricultural extension service or a private laboratory based on known or suspected contaminants that might be present in an area or region. Arsenic may be found in orchard sites and in areas where cotton has been grown. Selenium and boron, in some areas, are naturally high in concentration and may cause plant toxicities and can disrupt food chains and reduce targeted population densities. Sites where contaminants are found must be avoided or precautionary measures taken.

(2) Water

(i) Quality—Hydrologic conditions directly affect chemical and physical soil properties such as nutrient availability, substrate anoxia, and pH. Even modest changes in hydrologic conditions may result in significant changes in plant and animal species diversity and productivity. Therefore, the watershed and surrounding geomorphology of the proposed wetland site may need inventory and evaluation.

(ii) Quantity—In evaluating the suitability of a site, the source of the water that will supply the wetland must be carefully considered. Wetlands exist where inundation or saturation occurs for long enough periods to support anaerobic soil conditions and support hydrophytic vegetation. In addition, these conditions must provide the hydroperiod and hydrologic regime needed to meet the planned wetland function. In some

instances, a site may be selected that will require pumping or diverting of water from an offsite source. Whenever possible, these sites should be selected in areas where water can be provided in an energy-efficient manner by surface water or flow from an adjacent natural or manmade water source. Processes that require large amounts of energy, such as using pumped ground water as a primary water source, should be avoided because of high operation and maintenance expense. Using surface waters from offsite sources may require permits in several states and may be affected by water rights laws.

(iii) Storm event discharge—The resource inventory should include data in sufficient detail to determine the need for structure reservoir routing, whether the site is subject to active flood plain inundation or if it is supplied with perennial baseflow from offsite. This data is critical in selecting and locating wetland components. Figure 13–8 shows an example of stream gage data.

(3) Vegetation

When plans are relatively firm for the type or HGM class of wetland to be restored, enhanced, or created, the plans for site revegetation must be determined. It is critical that the project objectives, wetland HGM class, depths and durations, and desired species composition be determined up front. Once this has been done, decisions can be made as to whether the site needs to be revegetated as a whole, partially revegetated, enhanced with specific plantings, or whether the site can naturally revegetate on its own from a viable seed bank, seed wall, or by overbank flooding. Should the site be left to revegetate naturally, an evaluation of the desired species must be considered in relation to the existing propagules sources, as well as the likelihood of invasion by noxious, invasive, or problem species. Other criteria such as site conditions, budget, and seed availability are to be included into the decision; however, the site should be revegetated with the selected desirable species as quickly as possible. Otherwise, the site may revegetate with an inappropriate group of species and/or invasive species. Appendix C, parts 7 through 10, contains a checklist which provides some general guidelines in assessing vegetation and revegetation approaches based on planning considerations, vegetative community conditions, and function objectives. The determination of plant species value for wildlife and for erosion control can be found in the FOTG and other field office reference ma-

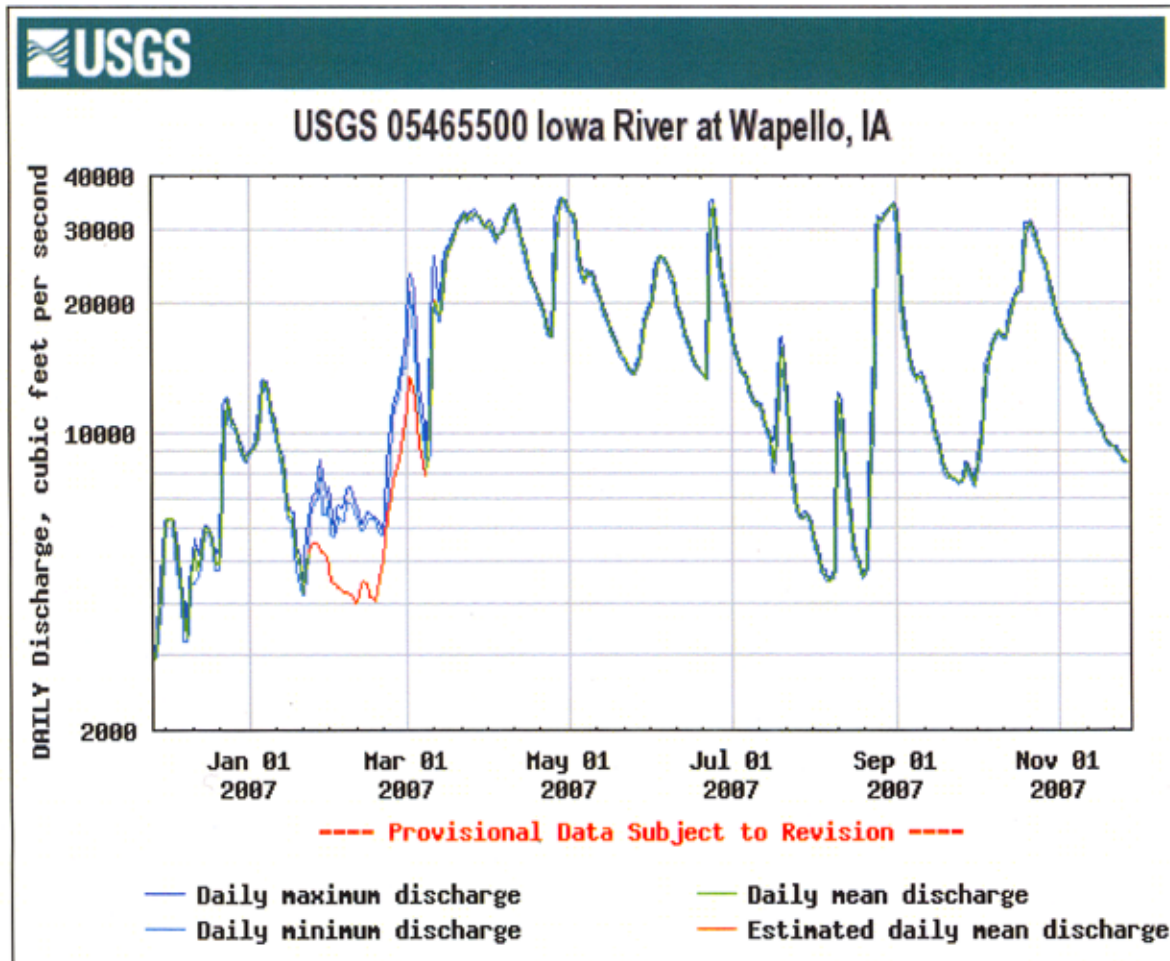
Figure 13-8 Riverine wetland planning may involve streamflow data collection

terials. The vegetation plan should include an assessment of land cover patterns on the landscape and indicate how the wetland fits into a larger pattern of habitats for wildlife.

(4) Wildlife and fish

Wildlife and fish use will change post-restoration, and it is important to quantify and document these use changes. This documentation is important not only to stay in compliance with NEPA requirements but also for accountability (what are we getting for our money). There are several recognized methods for site evaluation for wetland wildlife and fish. For small sites, simple surveys such as transects or call surveys conducted throughout a season, may suffice. For larger sites, more detailed evaluations that can help to accurately quantify wildlife and fish use can be used. Many of these incorporate models to assess the documented change. Some of these methods include (but are not limited to) the Habitat Evaluation Procedure (HEP), Wetland Evaluation Technique (WET), Index of Biotic Integrity (IBI), and individual state assessment methods. Each evaluation method has its strengths and limitations, so it is important that the user choose a method that will meet his or her needs. A good overview of wildlife evaluation methods as they pertain to wetlands can be found in *A Comprehensive Review of Wetland Assessment Procedures: A Guide for Wetland Practitioners* (Bartoldus 1999). State fish and wildlife agency biologists, Federal and local government biologists, nongovernmental organization biologists, academic and professional biologists, and published guidelines are an excellent source of species-specific habitat information.

(5) Plants and animals that may pose wetland management challenges

Restoring, enhancing, or creating wetlands may attract new or increased numbers of plant and animal species, some of which may prove to be a management challenge. In natural wetland communities, keystone species such as the beaver, muskrat, crayfish, and alligator establish and maintain heterogeneity within wetland systems through the process of their activities. These same activities may pose unique challenges to the design and maintenance of wetlands restored to meet specific functions utilizing traditional restoration methods. Embracing such organisms and their activities through innovative design and management will reduce long-term maintenance costs while promoting natural processes that will allow for natural vari-

ability and sustainability in wetland communities and functions. Listed below are some of the more common problem species and planning considerations for their control.

(i) Waterfowl—In urban and industrial areas, large numbers of ducks and geese have the ability to damage lawns and landscaped areas (fig. 13–9). Overuse by waterfowl can damage community parks or make them unpleasant to humans, and large numbers of waterfowl can adversely affect water quality in water supply reservoirs. Due to excessive waterfowl waste, wetlands may receive a high load of organics and become a source of unpleasant odors and mosquitoes. Discouraging the public from feeding waterfowl and planting a vegetated border of tall, rigid stemmed herbaceous vegetation around the wetland are ways to deter waterfowl loafing. It would not be prudent to locate wetlands that attract large numbers of geese near urban airports.

(ii) Mosquitoes—Dozens of mosquito species may breed in a wetland, but very few of these species, termed vector mosquitoes, are of concern to humans. Vector mosquito species generally breed in shallow, stagnant water where they are safe from predators and in waters that have high organic content in degraded wetlands with a compromised ecological community. To reduce the attractiveness of a wetland to breed-

Figure 13–9 Wetlands near airports can pose waterfowl management problems



ing mosquitoes, addressing nutrient and organic enrichment concerns and stabilizing hydrology within the wetland is of utmost importance, especially in urban areas. In addition, some species of mosquito avoid breeding in waters that house a diverse community of predatory insects or a large number of organisms that would compete for the same food resources as mosquito larvae. Thus, managing for a diverse ecological community can help to deter and control mosquito reproduction in wetlands.

In wetlands designed to maintain fish or that naturally house wetland fish species, vector mosquitoes may not be a problem unless there are extensive areas of shallow water less than 6 inches deep with fine-stemmed vegetation where fish can not maneuver. In some situations, it may be acceptable for populations of small, native wetland fish to be stocked and managed in suitable habitat within their natural range to provide mosquito larvae control. Before introducing any species of fish, local fisheries experts should be consulted, and careful consideration should be given to possible adverse impacts on populations of other native species, fish or otherwise.

The use of pesticides within wetlands to control mosquitoes is generally not recommended unless used as a last resort in areas where human health concerns are high. An exception to this would be applying pesticides to treatment wetlands that receive high levels of pollutants and do not support diverse biotic assemblages of plants and animals. Pesticides must be chosen carefully and applied following label instructions. The application of pesticides to wetlands could have significant negative impacts on nontarget species.

Bacillus thuringiensis israelensis or *Bacillus sphaericus* (BTI) is a biocontrol microbial larvicide which is ingested by and kills mosquito and other true fly (Dipteran) larvae. To date, BTI is not known to harm other insect or vertebrate species. True fly larvae are critically important decomposers of organic material and are the most abundant macroinvertebrate prey within wetland sediments. Keeping this in mind, treating wetlands with BTI to reduce mosquito concerns could have the potential to negatively impact other true fly species and their predators, a consideration that must be addressed especially when providing adequate wildlife habitat and food resources are targeted goals for wetland management.

Artificial wetland drawdown or drainage is a common, but ineffective practice used to control mosquitoes in some areas. The act of draining wetlands increases the amount of shallow, stagnant, short hydroperiod pools preferred by mosquitoes, while reducing the populations of organisms that prey on and compete with mosquito larvae. Contrary to traditional wetland drainage measures, restoring and maintaining a wetland's hydrology within the realm of historic, natural variability will have a greater effect in controlling mosquito populations without compromising nontarget organisms or other wetland functions. Reducing wetland access, using repellents, wearing appropriate clothing, and avoiding wetlands during peak mosquito activity periods and seasons are effective means in avoiding mosquito nuisance concerns.

(iii) Fish—Carp and other rough fish that invade wetlands can potentially destroy the aquatic plant community or compete with wetland animals for resources, reducing populations of desirable plants and animals. Designing wetlands that will experience natural drawdown due to seasonal or semipermanent hydrology will allow for natural control against rough fish. Although fish populations can be reduced by netting, the most effective method of rough fish control in permanent wetlands equipped with water control structures is to conduct a complete drawdown and allow the bottom sediments to dry. Special care must be taken to be sure that small pools of water do not remain when a complete drawdown is needed. Careful timing of water drawdown and potential impacts to nontarget plants and animals should be considered.

Wetlands with inflows or outflows connected to other water bodies may allow for fish passage and may require barriers to fish movement to keep undesirable fish out of, or in some circumstances within, the wetland being managed.

(iv) Vegetation—Some species of vegetation can become very prolific and cause problems in achieving planned wetland functions and values. For example, cattails can cover an entire shallow (less than 2 ft deep), nutrient-enriched wetland, eliminating other desirable vegetation or open water habitat. However, dense stands of cattails can also provide water quality benefits by removing nutrients and pollutants and provide habitat for some species such as the yellow headed blackbird. The planned function and value of the wetland must be considered before deciding upon veg-

etation control. Vegetation can be controlled chemically, mechanically, biologically, or a combination thereof. For sites with foreseen vegetation management challenges, water control structures may be planned to facilitate complete drainage and tillage of the wetland bottom or that allow water depth to be increased by at least 3 feet for a growing season. In addition, muskrats can be used as biological control agents for cattails, as can beavers for tree control.

(v) Mammals—It is claimed that the beaver is a close second to humans in the ability to change a landscape. For this reason, beavers can commonly become a problem within wetlands and along streams where they may burrow into banks or dikes or dam outflows (fig. 13–10). Adjacent to urban areas and within tree plantings, beavers may eat shrubbery and ornamental trees. The best defense against beaver invasion is to select vegetation beavers do not like. Consider using screened culverts and water control structures with anti-beaver devices or installing drains that prevent beavers from controlling the water level.

Muskrat and nutria are two other mammals that can cause problems in permanent water over 3 feet deep (fig. 13–11). Their burrowing activities may place levees and water control structures at risk unless extra width is planned. Like beavers, these animals start their burrows in deeper water, so planning for a wide, shallow berm or very gradual slope will help prevent problems. This same technique works well in circumstances where burrowing crayfish may be of concern to the stability of structures. If muskrats or nutria become problems, they can be controlled by trapping.

(6) Use and spatial organization

Analysis and selection of wetland sites must be based on an understanding of landscape ecology. Generally, proposed wetland changes will be of greater benefit, biologically and aesthetically, if they are planned as part of the naturally occurring aquatic ecosystem. Understanding existing patterns and connections between various landscape elements is critical to achieving planned objectives. For example, animals will colonize new areas if they can move upstream and

Figure 13–10 Beavers can be a nuisance animal



Figure 13–11 Muskrats can damage earthen dikes



downstream under cover with relative safety. Such cover can be rapidly developed through the use of soil bioengineering revegetation techniques or riparian plantings, which offer protection that ensures the natural function, health, and survival of fragile sites and species. Waterfowl need both open areas and cover to feed, roost, and nest, whereas some migratory songbirds need connected bands of trees and shrubs to provide movement corridors through the landscape. A restored wetland will colonize more quickly and become more productive if it is linked to existing wetlands. Fish and other aquatic species will inhabit wetlands that are hydrologically connected to streamflow during seasonal high flows. Where practical, restore wetland complexes that maximize biological diversity. Temporally and spatially, flood plain wetlands are key components of a river and its flood plain. Dry secondary channels and backwaters of rivers are re-wetted as the river rises during seasonal rains and isolated wetlands are reconnected to the river when discharge exceeds bankfull. The presence of such a dynamic connection between the stream and the riparian corridor maximizes the diversity of hydroperiod and hydrologic regime and increases the value of the associated function variables.

Wetland values are also enhanced when adjacent landscape conditions are taken into account. For example, buffers can increase wetland productivity by separating a restored or enhanced wetland from other areas

of incompatible use. Adjacent riparian forests, for example, will protect fragile wetland ecosystems while improving plant diversity, cover, and food sources within parts of the ecosystem. In addition, such a forest may reduce or prevent undesirable access to the wetland, temperature gain, encroachment by farm machinery, erosion, and overland nonpoint source pollution. Soil bioengineering technology may be used to quickly reestablish natural riparian zones to serve these needs and enhance overall wetland buffer functions.

Placing wetlands in headwaters of coldwater fish streams may adversely affect trout, salmon, and other coldwater fish since it can raise stream temperatures or decrease dissolved oxygen (fig. 13–12).

(7) Recreation

Wetlands can accommodate direct human use and recreation consumptive uses, such as hunting and fishing, and nonconsumptive uses such as educational tours and lectures, bird watching, nature trails, boating, hiking, jogging, biking, and horseback riding (fig. 13–13). Wetlands can be designed to be used for both categories or for a single purpose.

Incorporating human recreational use into a wetland site may involve designing access roads or paths, comfort facilities, observation platforms, fishing piers, hunting blinds, and any number of other structures as

Figure 13–12 Salmonids may be adversely affected by water warmed by wetlands



Figure 13–13 Wetlands provide nonconsumptive recreational use



part of the wetland. Structures will add to the costs of the overall project, but greater use and visibility of the wetland may make this a desirable trade off.

Structures should neither detract from the wetland nor interfere with its biological or other functions. For example, avoid placing trails or access roads through large homogenous ecosystems of core habitat to preserve as much interior biotic environment as possible. Trails should be located along the outer edge of a buffer zone which protects core habitat from disturbance. The attributes of a buffer zone should be defined early in the planning stages, with acceptable uses within the buffer zone clearly defined. It is also pertinent that linear barriers to animal movement, such as roads or wide trails, not be placed between important patches of habitat, for example, a road that parallels a water body, thereby cutting off bottomland to upland passage. In situations where such a barrier is unavoidable, planning for safe passageways (constructing crossings and/or barriers, or using traverse-friendly materials) may improve the ability for animal movement over, above, below, or along an obstacle.

Technical guides for designing recreational structures and facilities are available from the USACE, the USFWS, and the National Park Service.

(8) Aesthetic quality and open space

Aesthetic quality is a fundamental reason for choosing leisure and recreational sites. Many people perceive wetlands in modified rural and urban environments as remnants of the natural landscape. Land management decisions, including those related to wetland restoration, enhancement, or creation, are often made because of a landowner's perception of what will beautify the land and reflect a stewardship ethic to his or her neighbors.

Landowners may be reluctant to adopt conservation practices or landscape features that contradict aesthetic norms for attractive or well-cared-for land. A landowner's willingness to cooperate in wetland restoration or enhancement activities or to manage and protect a wetland over the long term can be directly related to the planner's ability to blend the wetland with the existing landscape. Wetlands contribute significantly to scenic quality, thereby attracting tourists or others seeking recreation and providing economic development opportunities. The edge of wetlands and other places where people enter the wetland site

are key opportunity areas for measures that display the landowner's intent to care for the land and include wetlands as an important part of land management.

As human populations continue to grow and require natural resources, the need for open space becomes increasingly important for both physical and psychological well being. Wetlands provide extremely important remnants of open space in many urban settings and contribute significantly to the pattern of open space to be found in the rural landscape (fig. 13-14). In addition to open areas of water, wetland open space can take the form of vegetated riparian corridors that may connect with other corridors to provide a complex pattern of greenway open space.

(9) Cultural features

Specific wetland benefits have always been valued, to a certain extent, throughout history. Wetland's clean, fresh water and abundant game made them attractive camp and settlement sites. Because of this, cultural resources may be encountered in and around wetland landscapes. These may include archeological sites, earthen features, and historic structures and buildings. Also, wetlands have unique preservation potential because they have low oxygen and high acidity, which reduce decay or bacterial breakdown. This means that preserved artifacts are more likely under these conditions.

Figure 13-14 Wetlands provide open space in manmade landscapes



Cultural resources need to be considered early in the planning process. Both NRCS General Manual (Title 420, Part 401.20) and the National Cultural Resources Training Program provide guidance for this process. They also contain procedures for when cultural resources are unexpectedly discovered. Planners need to work closely with landowners, an NRCS cultural resources coordinator, the State Historic Preservation Office, or Native American groups to ensure that proposed practices or installation do not harm significant cultural resources. This process is required by several Federal and state cultural resource laws and may be a requirement for a Clean Water Act, Section 404 permit.

(10) Social

Planners should work closely with the landowner during the planning process to ensure that their objectives are incorporated into the design when feasible. Due to Federal, state, and local regulations, the potential for conflict may exist between the landowner, planners, and other agencies. It is important for planners to recognize this potential and keep the landowner informed during the planning process. It is also important to be aware of any perceived or real impacts outside of the project area and its implications. For example, a restoration may not be hydrologically affecting adjacent landowners, but the perception may be different, so local informational public meetings may be needed to inform and educate those involved.

The NRCS Social Science Team (www.ssi.nrcs.usda.gov) has developed a broad array of guidelines and publications regarding the social components of conservation that can be very helpful when planning any conservation related project. These are available on the NRCS Web site under Technical Resources and Social Sciences.

(11) Economic evaluation

Monetary values associated with wetland restoration, creation, or enhancement are difficult to determine. It is relatively easy to base economic values on the production of forage or livestock water, hunting and fishing fees, visitor days, and other accepted measurements. It is much more difficult to determine economic values of wetland functions such as ground water recharge, water quality improvements, flood-flow alteration, preservation of open space, or aesthetic quality. Functional wetland benefits enjoyed by the general public can often equal or exceed those planned by the landowner.

Composite benefits to the overall landscape ecology, such as restoring fragmented habitats and connecting landscape patterns, although poorly understood, are also important.

Economic analysis can be performed with combinations of monetary and nonmonetary information. Performing a strictly monetary benefit-cost analysis for wetland creation, restoration, or enhancement is difficult because much information is lacking concerning the physical effects of wetland improvements. Two broad approaches can be used to resolve this problem. The first is to perform a least-cost analysis, which essentially requires determining the least costly way to achieve a given level of wetland values. The second is more comprehensive and involves displaying, for the decision maker, both the monetary and nonmonetary effects of each wetland improvement option. A key element in the analysis is to determine the base condition, or the benefits and costs associated with the current land use. The SCS Economics of Conservation Handbook, part 1, should be used when conducting an economic evaluation.

(12) Environmental evaluation

During planning, an environmental evaluation may be needed to comply with the National Environmental Policy Act and many state laws. States generally have checklists of environmental concerns.

In planning, potential impacts of alternatives to environmental concerns are considered. Proposed work must avoid harming such concerns as rare, threatened, or endangered species and archaeological sites that are protected by law. It should avoid or minimize affecting other environmental concerns.

Protection of threatened or endangered species or critical habitat is especially important since many such plant and animal species are associated with wetlands. Federal and state lists are maintained by NRCS, USFWS, NOAA National Marine Fisheries Service, state departments of natural resources, a state's Natural Heritage Program, or other appropriate state offices. These lists must be reviewed to verify whether species are present or that their habitats either exist or can be developed at the proposed site.

(13) Permits and regulation

It may be necessary to obtain Federal, state, or local permits prior to wetland restoration, enhancement, or creation. It is important to be aware of these regulatory issues during planning before designs are completed. Restrictions may exist that prevent the project from being designed as originally conceived.

(i) Section 404—Clean Water Act—Where a natural wetland exists, a Section 404 permit may be necessary before construction can begin. Section 404 of the Clean Water Act (33 U.S.C. 1344) and Section 10 of the Rivers and Harbors Act of 1899 (33 U.S.C. 403) are two of the Federal authorities for jurisdiction in wetlands of the United States. Permits are evaluated and issued by the USACE and subject to review by EPA. In addition, Section 401 of the Clean Water Act may sometimes require a water quality certification permit for a wetland construction project. In general, wetland restorations are covered under the Nationwide Permit No. 27 for Section 404 purposes. Contact with the local USACE permitting office is always a good idea to verify the project falls under the scope of the Nationwide Permit.

(ii) Water storage and diversion—Water law and water rights vary from east to west and state to state and can be very complicated. Western water rights, or the rights to adequate water supplies for certain uses, are controlled by each state and often by a local water district. On wetland sites where an adequate supply of clean water is in doubt, it is absolutely essential that this question be addressed before the wetland is planned and sited. Water rights may be obtained through outright purchase from local farmers or ranchers and, in some cases, through state assertion of water rights for protection and enhancement of natural resources in the public interest.

Eastern water rights or riparian rights rely on ownership of land along a water way and can include public navigability rights. In some states, a restoration on private land connected to public waters may make private waters public, so specific restoration designs may be necessary to protect a landowner's rights and interests.

(iii) Flood plain—In flood plains included in the National Flood Insurance Program, is necessary to obtain a local permit for a project which has the potential to raise the 100-year flood elevation. Normally, it

is prohibited to raise the flood elevation in the defined floodway, and areas outside the floodway are limited to 1 foot or less increase in flood elevation. It may be necessary to perform complex water surface profile analysis to document the projects effects on the flood elevation for a permit. The local permit program is usually administered by city or county government. The permitting entity will have information about the FEMA funded flood studies, and data needed to perform an analysis. Most NRCS field offices have copies of the FEMA flood study maps for their district.

Projects which store water above natural ground and/or include dikes can potentially increase the flood elevation.

(iv) Dam safety—The requirements for dam safety permits vary widely across the country. The need for permits is usually based on some combination of storage volume and structure height. Many states consider embankments of 6 feet or less in height to be dams, and many wetland embankments store significantly more water above natural ground than the typical embankment pond.

(v) National Point Discharge Elimination System—The EPA's National Pollutant Discharge Elimination System (NPDES) permit system is usually administered by the states. It requires permits for construction activities which have the potential to discharge sediment and other pollutants from construction sites until permanent cover has been established. Best Management Practices for sediment control, discharge of hazardous construction materials, and control of spills of equipment fuels and lubricants are usually required. Individual states have set permit requirements based on location of the activity, and size of the disturbed area. The permits are administered by the state agency responsible for environmental protection.

(vi) Easements—The number of potential easements on a project site are too numerous to mention in their entirety. Easements are recorded on property ownership documents. They may require a project proponent to obtain permission from the easement holder to conduct the activity. The following are some of the most common easement issues:

(vii) Utilities—Buried or overhead electrical, telephone, oil, gas, water, and other utilities owners will

always have an easement across the property and will almost certainly have a concern with the alteration of the land over or under their easement or the construction activity.

They commonly require, at a minimum, that constructed access routes be maintained through the project. It is common to require the owner to pay the expense of new construction and land rights to relocate the utility.

(viii) Water storage or flowage—The landowner of a wetland project must obtain an easement for any water stored on an adjoining property, both permanently or temporarily. Also included are any waters diverted away from their original, natural flow path. Many states have defined the minimum return period of the storage event. It is easy to overlook water storage requirements under state laws.

An example would be a wetland structure designed to safely handle a 10-year storm discharge. The top of this structure was lower than the lowest elevation along the upstream property line. However, state law required that an easement be obtained up to the water surface during a 100-year runoff event. This same structure, when overtopping during the 100-year event, would back water across the property line.

(ix) Irrigation, drainage, and levee districts—These entities often have easements on ditches, canals, dikes, levees, or other features in a wetland project area. In some cases, the actual boundary and width of these easements are indeterminate. Also, many old easement holding entities have disbanded, merged with other entities, or turned their easement over to another entity. In addition to easements, there may be set-back requirements. For instance, the USACE usually has a set-back distance for excavations adjacent to its project levees.

(d) Planning step 5—Formulate alternatives

Once the problem is defined, objectives are set, and data is collected and analyzed, project alternatives can be developed. It is recommended that at least two alternatives, which are in keeping with the project objectives, be developed.

(e) Planning step 6—Evaluate alternatives

Alternatives are analyzed by the project's decision makers and based on many factors. The following is a list of factors which should be considered:

- *Construction cost*—reflects the availability of materials, equipment, and construction contractors locally available to do the work. It also reflects the relative difficulty of constructing the wetland components.
- *Maintenance costs*—estimated costs for keeping constructed structures, vegetation, etc., in the condition required for the planned wetland function throughout the life of the project components.
- *Management costs*—includes the costs, required skill and experience, and time required to manage the planned wetland components in accordance with project objectives. Although some of these factors are subjective and qualitative, an effort should be made to assign costs. Included are costs for invasive species control, mowing, water control structure operation, etc.
- *Projected life span of components*—takes into account the cost of replacement, rehabilitation, and maintenance of wetland components. These efforts can be used to determine a life cycle cost for the project alternative.
- *Project benefits*—can be addressed by using the local HGM class functional assessment to determine which alternative has the highest increase in function. Although it is difficult to assign a monetary value to functions, it is still useful for comparisons with other costs.

Other factors to consider include:

- relative aesthetic quality
- other landowner or societal benefits beyond the project objectives
- flexibility of the project in terms of future modifications or merging with future adjacent projects

(f) Planning step 7—Make decisions

One of the most difficult steps in the planning process is the decision-making process. Often, there are multiple decision makers. In addition, funding, government program requirements, and permitting requirements affect the selection of project alternatives. However, if the planning process has been followed up to this point, any selected alternative will meet the objectives of the project and will be appropriate for the project objectives.

Planning steps 8 and 9 include the engineering design of the selected alternative, its construction, acceptance by the project owner or sponsor, and evaluation of the project's performance. These items are included later in this chapter.

650.1304 Design

The design process does not begin until the previous planning steps have been completed up to the selection of the plan alternative. The designer is responsible for data collection, analysis, design, plans, specifications, construction cost estimates, construction contract documents, construction quality assurance, and certification of the completed work. The designer becomes familiar with the objectives of the project and works to deliver engineering services required to provide a project that meets the objectives.

As a member of a multidisciplinary project team, the designer is involved in the planning process from the beginning. He or she can provide valuable input in data collection and analysis and the development of plan alternatives. This ensures the designer's complete understanding of the project objectives and prevents the development of alternatives that are later found to be not feasible. The designer also informs the project planner when the selected alternative is found to have problems not anticipated in the alternative development step and assists in modification of the plan. The designer communicates with and solicits input from the project team members throughout the implementation phase of the project.

A wetland restoration, enhancement, or creation project is a system with individual components that work together to perform the planned functions. As such, the criteria in the individual eFOTG, Section IV, Conservation Practice Standards (CPS) must be followed. A partial list of the available CPSs include Dike—356, Structure for Water Control—587, Grade Stabilization Structure—410, Diversion—362, Grassed Waterway—412, Water and Sediment Control Basin—638, Open Channel—582, and Streambank and Shoreline Protection—580. Each of these practices has individual criteria for design storm, freeboard, size, et cetera. Each also has individual Engineering Job Approval Authority limits.

(a) Data collection

(1) Surveys

Once an alternative has been selected, adequate engineering surveys are needed to perform the design.

Survey data may have been obtained during the planning process, but the designer must determine their adequacy and supervise the collection of additional data. The final survey data should include:

- surface topography—includes the maximum potential flooded area of the wetland during extreme storm runoff events and the maximum potential area of ground water rise. Include the areas that may experience a water surface profile increase in drainage ditches and stream channels. Due to the special nature of wetland projects, the topographic contour interval should be no greater than 1.0 feet. Consider obtaining sufficient data for accurate 0.5 foot contours.

In small, noncomplex projects, spot elevations, profiles and cross sections may be adequate for survey.

- location of roads, rights-of-way, utilities, or other public infrastructure
- potential flowage path of auxiliary spillways to the original downstream point of discharge of the hydrologic system
- potential downstream breach hazard areas of planned water impoundments to the point of discharge into the 100-year flood plain of downstream receiving waters

- location, size, and dimensions of hydraulic structures on and off project that will affect the flow of surface and subsurface water into and out of the wetland. This includes road culverts, drain tiles, drainage ditches, conduits through embankments, and other structures (fig. 13–15).
- location of property boundaries, project easement boundaries, buildings, structures, significant individual trees or timber boundaries, significant remnant or declining habitat, and fences
- existing benchmarks, boundary markers, or other control points which can be potentially “tied-in” to the project horizontal and vertical datum
- profiles and cross sections at the planned location of significant water control structure conduits and embankments, if needed to provide sufficient detail
- locations of soil boring or test pit locations
- other special areas of concern such as known or potential cultural resource sites, hazardous material disposal areas, or endangered species nesting sites

Surveys can be performed by many different technologies including transits, plane table and alidade, total station instruments, and Global Positioning Systems (GPS) (fig. 13–16). On sites where Laser Imaging

Figure 13–15 Surveys should locate existing water conveyance structures



Figure 13–16 Survey-grade GPS equipment increases the efficiency of topographic surveys



Detection and Ranging (LIDAR) topography is available, it is still necessary to survey in benchmarks to the same datum. These are used to transfer design lines and grades to the ground surface. This is also the case where GPS topography has been provided. GPS topography must be “survey grade.”

If the potential project site is to have an easement boundary survey performed, consider specifying that the surveying contractor provide the horizontal and vertical coordinates of boundary markers in the project datum.

At least two solid benchmarks must be set that will not be destroyed during construction and will last at least a few years in the event project construction is delayed. These benchmarks will also be used for monitoring once construction is completed. They should be tied to locally recognized benchmarks with mean sea level vertical datum whenever possible, especially for large and perpetual projects. They should also be referenced to a horizontal datum system such as Universal Transverse Mercator (UTM) or State Plane Coordinate. Consider using 5/8-inch-diameter reinforcing steel bars at least 30 inches long, protected with a steel fencepost.

Guidelines for surveying techniques and note keeping can be found in EFH, Chapter 1, Engineering Surveys, as well as NRCS Technical Release No. 62 (TR-62).

(2) Geotechnical investigation

The geotechnical investigation is performed for two distinct purposes. The first is to determine the nature of surface and subsurface soils and the source and direction of ground water movement. This information, if not obtained in the planning process, is needed to properly analyze the wetland water budget and the resultant effects on wetland function. The data needed will vary by HGM wetland type and is determined by the wetland's dominant water source and hydrodynamics. A partial list of data needed for wetland function may include:

- shallow soil boring to determine location and depth of low permeability soil horizon
- piezometer and monitoring well information for determination of ground water movement
- chemical analysis of wetland soil for inventory of available nutrients

- analysis of wetland soil to determine seed bank
- measurements of saturated hydraulic conductivity (vertical and horizontal) (fig. 13–17)

The second purpose is to determine the properties of surface and subsurface earth materials for the design of planned structures. This is referred to as a **geologic investigation**.

The intensity of the geologic investigation is dictated by the size, potential hazard, and engineering job approval authority requirements of the project's structural components. Soil borings or test pits should be located along the planned centerline of embankments and water control structure conduits and the planned locations of borrow. The material is logged in accor-

Figure 13–17 Soils investigation



dance with the USCS. The borings or pits should extend down to the maximum influence of structure loads on foundations or the effects of water impoundment head on water loss or piping potential. If needed, undisturbed samples are obtained for laboratory analysis of settlement, consolidation, seepage, and strength. Soils that are potentially dispersive are tested on site or retained for laboratory analysis. The investigation should also determine the current and seasonal high water table.

Guidelines for the USCS and logging can be found in EFH, Chapter 4, Elementary Soil Engineering.

In complex projects, the services of a trained geologist/geomorphologist may be needed.

Table 13–2 provides guidance for the use of USCS soil types in dikes.

Table 13–2 Soil characteristics related to dikes

Group symbol	Soil description	Suitability for class III dikes	Permeability and slopes
GW	<ul style="list-style-type: none"> Well-graded gravels and gravel-sand mixtures Little or no fines 	<ul style="list-style-type: none"> Very stable—suited for shell of dike Good foundation bearing 	<ul style="list-style-type: none"> Rapid
GP	<ul style="list-style-type: none"> Poorly graded gravels and gravel-sand mixtures Little or no fines 	<ul style="list-style-type: none"> Stable—suitable for shell of dike Good foundation bearing 	<ul style="list-style-type: none"> Rapid
GM	<ul style="list-style-type: none"> Silty gravels and gravel-sand-silt mixtures 	<ul style="list-style-type: none"> Stable—generally adequate for all stages Good foundation bearing Good compaction with rubber tires 	<ul style="list-style-type: none"> Moderate
GC	<ul style="list-style-type: none"> Clayey gravels and gravel-sand-clay mixtures 	<ul style="list-style-type: none"> Stable—adequate for all stages Good foundation bearing Good compaction with rubber tires 	<ul style="list-style-type: none"> Slow permeability
SW	<ul style="list-style-type: none"> Well-graded sands and gravelly sands. Little or no fines 	<ul style="list-style-type: none"> Very stable—adequate for class III dikes Good foundation bearing Compaction can be done with crawler tractor 	<ul style="list-style-type: none"> Rapid
SP	<ul style="list-style-type: none"> Poorly graded sands and gravelly sands. Little or no fines 	<ul style="list-style-type: none"> Stable—adequate for class III dikes Generally fair foundation bearing Use flat slopes and wide berm Compaction can be done with crawler tractor 	<ul style="list-style-type: none"> Rapid Use flatter slopes Protect against wave action
SM	<ul style="list-style-type: none"> Silty sands and sand-silt mixtures 	<ul style="list-style-type: none"> Fairly stable—adequate for low stages Only fair foundation bearing Use wide berm Good compaction with rubber tires 	<ul style="list-style-type: none"> Moderate—use flat slope on waterside Protect against wave action
SC	<ul style="list-style-type: none"> Clayey sands and sand-clay mixtures 	<ul style="list-style-type: none"> Stable—adequate for all stages Generally good for foundation bearing Fair compaction with rubber tires 	<ul style="list-style-type: none"> Slow permeability

Table 13–2 Soil characteristics related to dikes—Continued

Group symbol	Soil description	Suitability for class III dikes	Permeability and slopes
ML	<ul style="list-style-type: none"> Inorganic silts and very fine sands, rock flour, silty or clayey fine sands and clayey silts of slight plasticity 	<ul style="list-style-type: none"> Low stability—generally adequate for low stages Fair foundation bearing Dumped fill should be used on class III only Fair compaction with rubber tires 	<ul style="list-style-type: none"> Moderate—use flat slope on wet side Protect slopes against all erosion forces
CL	<ul style="list-style-type: none"> Inorganic clays of low to medium plasticity, gravelly clays, sandy clays, silty clays, and lean clays 	<ul style="list-style-type: none"> Stable—adequate for all stages Fair foundation bearing Fair compaction with rubber tires Use dumped fill on lower stages only 	<ul style="list-style-type: none"> Slow permeability
OL	<ul style="list-style-type: none"> Organic silts and organic clays having low plasticity 	<ul style="list-style-type: none"> Very low stability—may be adequate for class III dikes of low height Can use dumped fill 	<ul style="list-style-type: none"> Moderate—use for very low stage only Slopes at natural angle of repose when wet
MH	<ul style="list-style-type: none"> Inorganic silts, micaceous or diatomaceous fine sandy or silty soils, and elastic silts 	<ul style="list-style-type: none"> Low stability—generally adequate for all stages Difficult to compact Could use dumped fill for low stages Poor foundation bearing 	<ul style="list-style-type: none"> Slow permeability Use flat slopes and protect against erosion
CH	<ul style="list-style-type: none"> Inorganic clays having high plasticity and fat clays 	<ul style="list-style-type: none"> Fairly stable—adequate for all stages Poor compaction, dumped fill may be adequate 	<ul style="list-style-type: none"> Very slow permeability Use flat slopes on wet side
OH	<ul style="list-style-type: none"> Organic clays having medium to high plasticity and organic silts 	<ul style="list-style-type: none"> Very low stability—adequate only for low stages and can use dumped fill Has poor foundation bearing and compaction 	<ul style="list-style-type: none"> Very slow—use for low stages only Use flat slopes
PT	<ul style="list-style-type: none"> Peat and other highly organic soils 	<ul style="list-style-type: none"> Very low stability— use only for temporary dikes Remove from foundation for mineral soil dikes 	<ul style="list-style-type: none"> Variable—may vary significantly between vertical and horizontal

(3) Hydrology data

A hydrologic analysis is done for two purposes. The first is to determine the volumes and peak rates of discharge of surface runoff, or the expected stream hydrographs for hydraulic design of the wetland project components. The second purpose is to determine the values needed to analyze the wetland's water budget. The following discussion includes both purposes.

For a wetland to be functional, it must have adequate amounts of water during appropriate times of the year (the wetland's **hydroperiod**). It must also provide the planned depths of water (**hydrologic regime**). Hydrologic studies of existing or potential wetland systems may be relatively simple and require only a few assumptions and estimates; however, some wetlands may be so complex that they require the services of a hydraulic engineer. An examination of the water budget; the relationship between the water budget, hydroperiod, and regime; and the flow characteristics within a wetland are necessary to understand wetland hydrology.

Detailed information on wetland hydrology tools can be found in NEH650.19, Hydrology Tools for Wetland Determination.

(i) Water budget—The basic formula for the water budget is:

$$\frac{\Delta S}{\Delta t} = q_i - q_o \quad (\text{eq. 13-1})$$

where:

$\Delta S/\Delta t$ = change in storage volume per change in time

q_i = flow rate of water entering the wetland, vol/time

q_o = flow rate of water leaving the wetland, vol/time

Equation 13-1 translates into the following equations where all values are given in consistent units of units of volume unless otherwise specified. For water entering a wetland the formula is:

$$Q_i = P + R_i + B_i + G_i + P_i + T_i \quad (\text{eq. 13-2})$$

where:

Q_i = volume of water entering the wetland

P = direct precipitation on impoundment area

R_i = storm event water runoff from contributing drainage area

B_i = baseflow entering the wetlands

G_i = seepage and springs from ground water sources

P_i = water pumped or artificially added to the wetland

T_i = tidal flow in

For water leaving a wetland the formula is:

$$Q_o = P + R_o + B_o + G_o + P_o + T_o + E + T \quad (\text{eq. 13-3})$$

where:

T = transpiration from plants

Q_o = volume of water leaving the wetland

R_o = storm event outflow

B_o = baseflow leaving the wetland

G_o = deep percolation below the root zone of the substrate

P_o = water pumped or artificially removed from the wetland

T_o = tidal flow out

E = evaporation from surface water or wet soil surfaces

For water stored in a wetland, in units of volume, the formula is:

$$S = S_s + S_p \quad (\text{eq. 13-4})$$

where:

S = total volume of water stored in a wetland

S_s = volume of stored surface water

S_p = volume of water in the wetland substrate (soil)

Following is a description of each of these factors and guidance on how to develop numerical values for the factors.

Precipitation (P)—The amount of rain and other precipitation (P) that falls directly on a wetland can be determined from local precipitation data. The precipitation records are used for analysis of averages over a chosen time step (such as monthly), as well as statistical maximum events (such as 10-year, 24-hour precipitation).

Direct precipitation is the dominant water source for mineral and organic flat HGM wetland types. It is also a major component of depression wetlands, es-

pecially playa systems with no ground water inflow. Precipitation data is available in two forms. Monthly precipitation statistics data can be found in the WETS tables obtained through eFOTG or at <http://www.wcc.nrcs.usda.gov/climate/wetlands.html>.

The data is provided as average, and 30 percent chance “less than” and “more than” average amounts. In addition, monthly totals are provided for the period of record for the available weather stations. Daily precipitation data for a weather station period of record can be obtained from the National Water and Climate Center at <ftp://ftp.wcc.nrcs.usda.gov/support/climate/daily-data/>.

This data consists of actual daily precipitation totals, as well as temperature data. The daily data in these files is used in the Soil-Plants-Air-Water (SPAW) computer model.

In general, monthly statistical data is used for analysis by hand calculations or simplified spreadsheet tools. Daily data is used when utilizing the SPAW or other computer software.

Surface water runoff (R_i and R_o)—Storm water runoff is an important component of the water budget for both depressional and riverine HGM type wetlands. It is not a significant component for flats, tidal and estuarine fringes, or slope wetlands. The analysis of storm water runoff differs considerably between riverine and depressional systems.

- **Riverine**—Riverine wetland systems receive water from the stream. Water is supplied to the surface of the riparian wetland during flood events (episaturation). It can also be supplied as ground water. This ground water surface is supported by the water surface profile of the stream, and water flows through the wetland soil creating wetland conditions (endosaturation). In riverine systems, the flow **rate** (ft^3/s) and **duration** are the critical parameters. This information is provided by the stream hydrograph. The hydrograph determines the extent of inundation during flood events and provides the needed information to design water control structures and other hydraulic features. A water balance analysis using runoff volumes is usually not relevant.

Detailed information on the analysis of riverine wetland hydrology can be found in NEH 630.19,

Hydrology Tools for Wetland Determination. NEH630.13 has procedures for developing stage inundation relationships, and the Stream Corridor Restoration Manual provides general planning, hydrology, and hydraulics information. Data for streamflow at individual stream gage sites including peak discharges, statistics, and hydrographs is available from the USGS at <http://waterdata.usgs.gov/nwis/sw>.

- **Depressional**—In depressional systems, the designer is concerned with the volume and timing of surface runoff for analysis of hydroperiod and hydrologic regime. If water control structures are utilized, peak discharges may need to be determined. The runoff volumes are used in a water balance analysis to optimize the size of wetland depressions and determine the extent of different hydrologic regimes within the wetland.

Traditional surface runoff volume computation methods using the NRCS runoff curve number (RCN) must be modified somewhat for the analysis of wetland hydrology. The RCN method was developed for determination of runoff volumes for single rainfall events. Wetland hydrology requires the use of daily, weekly, or monthly total rainfall amounts to determine the corresponding runoffs. These rainfall amounts represent the sum of all precipitation for the time increment. Various methods have been developed for determination of the appropriate adjusted curve number to use for these rainfalls. One procedure uses a curve number adjustment which converts the single storm RCN to an equivalent RCN to use with monthly average rainfall to determine the average monthly runoff. This 30-day RCN (CN_{30}) is used in the Agricultural Waste Management (AWM) computer program. Other information on runoff hydrology associated with depressional wetlands can be found in NEH650.19, Hydrology Tools for Wetland Determination.

Design of individual wetland structures can be very adequately done using traditional methods. For these applications, the need is to determine the structures ability to function during a specific return period storm. The watershed RCN is assumed to be a single, conservative value. Runoff hydrographs from the contributing drainage area can be determined with the use of EFH, Chapter 2, Estimating Runoff and Peak Discharge, for

drainage areas of 2,000 acres or less and the associated EFH2 computer program. NRCS Technical Release WinTR55 methods can be used for drainage areas up to 20,000 acres.

Evaporation and transpiration (E and T)—

Evaporation (E) is the water released from the wetland to the atmosphere from an open water surface or from the surface of the exposed bare soil. Evaporation is normally estimated from pan or free water surface (FWS) (lake) evaporation data collected at a nearby station (NOAA records). FWS (lake) and pan evaporation data can be found in NOAA Technical Report NWS 33 and 34, available at <http://www.weather.gov/oh/hdsc/studies/pmp.html#Tech34>.

Transpiration (T) is the water released to the atmosphere from the leaves of emergent vegetation. If wetlands contain large open areas with little emergent vegetation, evaporation and transpiration can be considered separately. If wetlands are covered with vegetation, evaporation and transpiration may be calculated together as evapotranspiration (ET). It may be necessary to consult a water management engineer or an agronomist for estimates of ET. Evapotranspiration is a critical loss of water to wetlands in flats and certain depressional wetland systems such as playas, vernal pools, and Carolina bays. It is of less importance in evaluating the hydrology of flooded riverine systems. The evapotranspiration due to hydrophytic vegetation is not well understood and varies considerably by wetland type and region.

A good estimate of peak ET rates can be determined by using the Modified Blaney-Criddle method to determine the potential evapotranspiration (PET), described in NEH, Part 623, Chapter 2, Irrigation Water Requirements. The method is included in the Irrigation Water Requirements (IWR) computer program. The calculations are made on a monthly time-step basis. This method can be used with readily available data from the WETS tables for the local area available from the National Water and Climate Center at <ftp://ftp.wcc.nrcs.usda.gov/support/climate/wetlands/>.

In many cases, the peak ET rates at the height of the growing season are within 10 percent of the Modified Blaney-Criddle potential evapotranspiration for herbaceous vegetation. The crop curve coefficients for the early and late parts of the growing season are less certain, however. There is currently no database of wet-

land plant community ET rates available that relate climatic factors, plant communities, growth stage, and available water to ET rates.

Factors to consider when performing estimates of E, T, and ET are:

- Dense herbaceous plant communities greatly reduce the solar radiation, temperature, and wind velocities which drive surface evaporation. Early in the season, standing dead vegetation of annual plants will greatly reduce FWS E and will have low ET rates until the plants have grown to maturity.
- Perennial herbaceous vegetation will increase ET rates earlier in the season than annual vegetation, because annual plants must produce new biomass each year, and biomass volumes are small at the start of plant growth.
- The peak ET rates of herbaceous plants may be relatively close to the daily PET rates in mid-summer, computed by various methods.
- The ET rates of wetland plants may be closely tied to the soil moisture content or depth to ground water.

Baseflow (B_i and B_o)—The baseflow includes all sources of surface flow entering (B_i) or leaving (B_o) a wetland in the period between storm runoff events.

Baseflow enters or leaves a wetland over long durations through single point discharge locations. The baseflows entering or leaving wetlands can be determined directly by the use of a current meter. It can be estimated by measuring the cross-sectional area of the flow channel and multiplying that figure by the average velocity. It can also be measured with various water measurement devices such as Parshall flumes, Cipoletti weirs, or Ramp flumes. Details on the geometry and rating curves of these devices can be found in the Water Measurement Manual published by the U.S. Bureau of Reclamation (USBR). Baseflow information may be needed for hydraulic design of water control structures. For instance, the weir length of a stop log structure needed to maintain water level depends on the anticipated baseflow.

In certain cases, the baseflow for structure design can be determined by the use of drainage curves. Drainage curves are appropriate in humid regions, where the

drainage area slopes are 1 percent or less. They can be used to determine the capacity of water control structures for wetland water level management. They may also be used in determining the storage capacity requirements of wetland embankments. They will not provide inflow hydrographs for reservoir routing.

Drainage curves are expressed in the form:

$$Q = CM^{\frac{5}{6}} \quad (\text{eq. 13-5})$$

where:

- Q = required capacity of structure, in ft³/s
- C = a coefficient related to the characteristics of the watershed and the magnitude of the storm against which the structure is to be protected
- M = drainage area, in mi²

Detailed information on the development and use of drainage curves and the coefficients for use in the drainage formulas can be found in NEH, Section 16, Drainage of Agricultural Land.

The presence of baseflow entering and leaving an existing wetland provides a unique opportunity for determination of current losses due to evapotranspiration and/or ground water flow. The difference in flows, measured by a current meter, can be attributed to evapotranspiration and ground water flow. A series of these measurements conducted throughout the growing season can be used to calculate a crop coefficient to use with a PET, if ground water gains or losses can be accounted for. This coefficient can be applied to the water budget of a restored or enhanced wetland on site or at another location in the local area. The gains or losses due to ground water can be assumed to be constant if the wetland depth and area are constant; otherwise, they can be proportioned to wetland extent during the growing season.

Ground water (G_i and G_o)—Ground water inflow and outflow are the major components of the water budget for many wetlands. The quantification of these flows is usually the hardest to determine with any accuracy. Ground water moves laterally through seepage and springs and can leave a wetland through vertical downward movement. Ground water flow is usually less seasonal than surface water flow. If interaction with ground water has a significant impact on the water budget, the services of a ground water geologist or

a water management engineer may be required. The need for this information is especially critical in the analysis of ground water influenced depressional systems such as prairie potholes in the Northern Plains. The analysis of ground water flow in wetlands can be broken into two categories: the direction of flow and seasonal pattern of ground water levels, and the actual volume of flow.

Water levels and flow direction—Analysis of the direction of ground water movement is perhaps more important than volumes in many wetlands. Determinations of ground water flow directions can determine if the wetland is in a discharge, recharge, or flow through condition. It can help predict offsite effects of wetland restoration or enhancements and resulting salinity levels. The level of water tables is determined with shallow monitoring wells. The installation and use of these are described in Engineering Field Manual (EFM), Chapter 19. Information on proper installation can be found in the USACE publication ERDC TN-WRAP-05-02, Technical Standard for Water Table Monitoring of Potential Wetland Sites, available at <http://el.ercd.usace.army.mil/elpubs/pdf/tnwrap05-2.pdf>.

The function of a monitoring well is to determine the USFWS water table elevation of the entire soil profile. The well is screened throughout its length, so any variation in hydraulic head is integrated throughout the soil profile.

To determine the direction of movement of water into or out of a wetland, piezometers may be needed. They are installed in sets of two or more or in conjunction with monitoring wells. The function of a piezometer is to determine the hydraulic head at a specific soil layer. When compared with the head in an adjacent piezometer in a different soil layer or a monitoring well, the direction of movement can be determined. If all piezometers/wells are installed at the same site, the determination will be limited to vertical movements. Installations at two or more locations can determine directions of movement in the horizontal plane also. ERDC TN-WRAP-00-02 describes the installation of piezometers and can be found at <http://el.ercd.usace.army.mil/elpubs/pdf/tnwrap00-2.pdf>.

Ground water investigations are also described in EFH, Section 16, Drainage of Agricultural Land, Chapter 2.

Figure 13–18 shows the case of downward movement detected by wells and piezometers.

Figure 13–19 shows the case of upward movement detected by wells and piezometers.

Figure 13–18 Downward movement detected by wells and piezometers

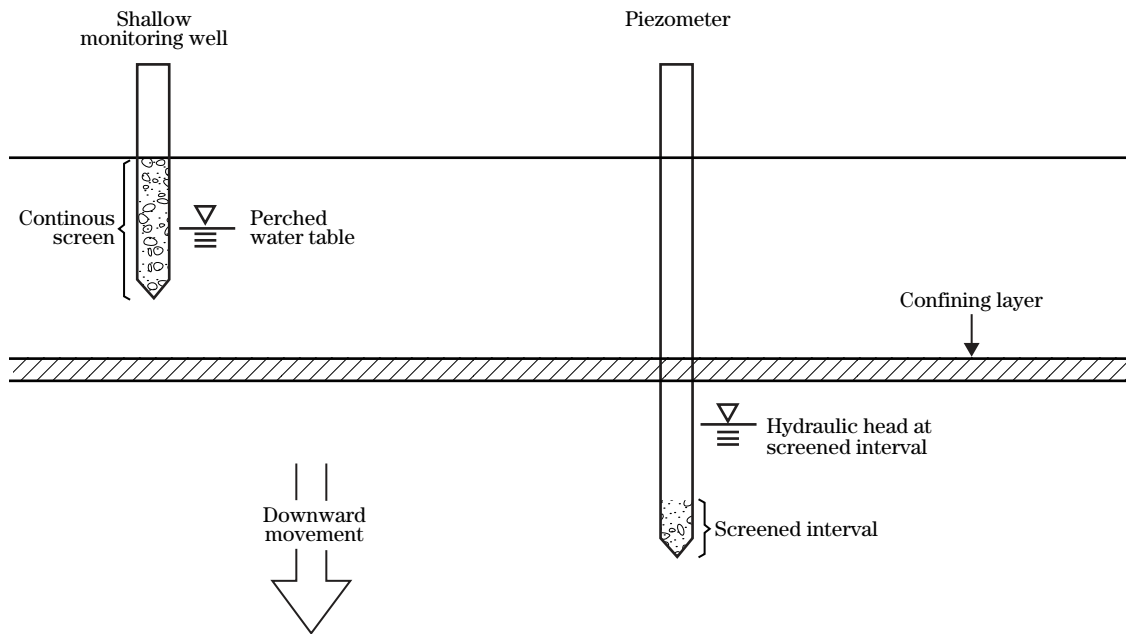
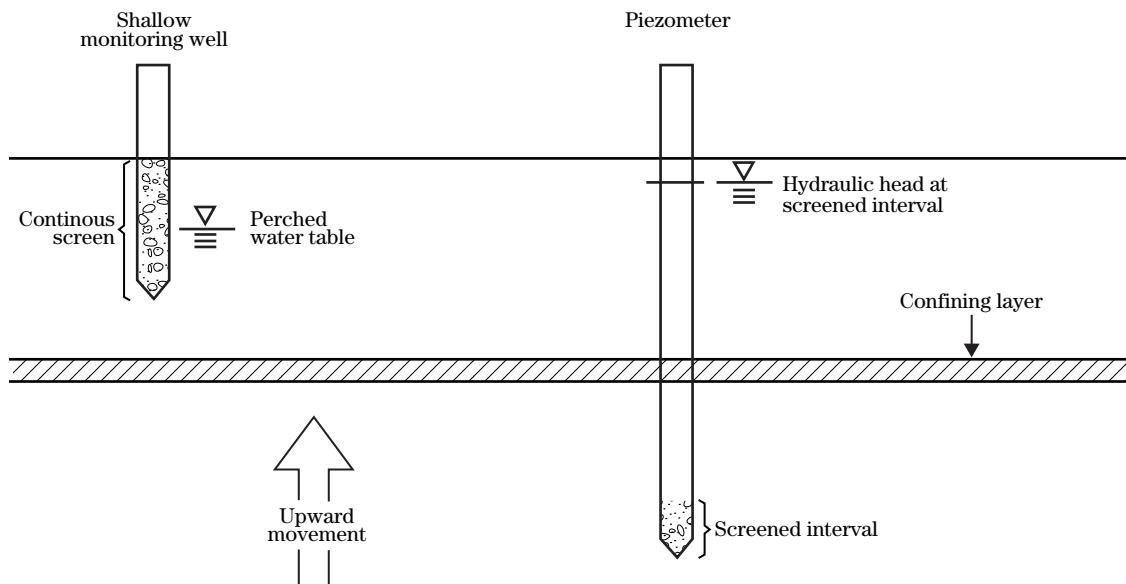

Figure 13–19 Upward movement detected by wells and piezometers



Volumes of flow—One of the simplest methods of quantifying the volume of ground water flow is to measure the difference in the baseflow entering and leaving a wetland over a given time period, if evapotranspiration losses can be accounted for. Methods for estimation of baseflow, evaporation, and transpiration losses are described elsewhere in their respective water budget sections. Otherwise, estimates of the volume of subsurface flow can be made using Darcy's equation:

$$G_o \text{ (or } G_i) = KiA \quad (\text{eq. 13-6})$$

where:

K = hydraulic conductivity

i = hydraulic gradient, $\Delta h/\Delta L$

A = cross-sectional area of flow

Δh = change in hydraulic head

ΔL = flow distance

The hydraulic gradient can be determined from the difference between the water levels in two or more wells or piezometers. The gradient, i , is the difference in water level, Δh divided by the distance of travel through the soil, ΔL . For two piezometers at the same location, but at different levels, the flow distance is the distance between the screened intervals. The parameter K_{sat} is the saturated hydraulic conductivity, or the flow rate under saturated conditions. Laboratory or field tests can be conducted to determine this figure. Table 13-3 lists some typical values for K_{sat} which may be used in lieu of more precise information. The cross section is the area of flow through the strata.

Example 13-1 illustrates an estimation of ground water inflow using monitoring well data.

Table 13-3 Hydraulic conductivity vs. soil texture

Soil type	Min. K_{sat} (ft/s)	Max. K_{sat} (ft/s)
Clays	< 3.3×10^{-8}	
Peat	3.3×10^{-8}	3.3×10^{-7}
Silt	3.3×10^{-7}	3.3×10^{-6}
Loam	3.3×10^{-7}	3.3×10^{-5}
Very fine sands	3.3×10^{-6}	3.3×10^{-5}
Coarse sands	3.3×10^{-4}	3.3×10^{-3}
Sand with gravel	3.3×10^{-3}	3.3×10^{-2}
Gravels	> 3.3×10^{-2}	

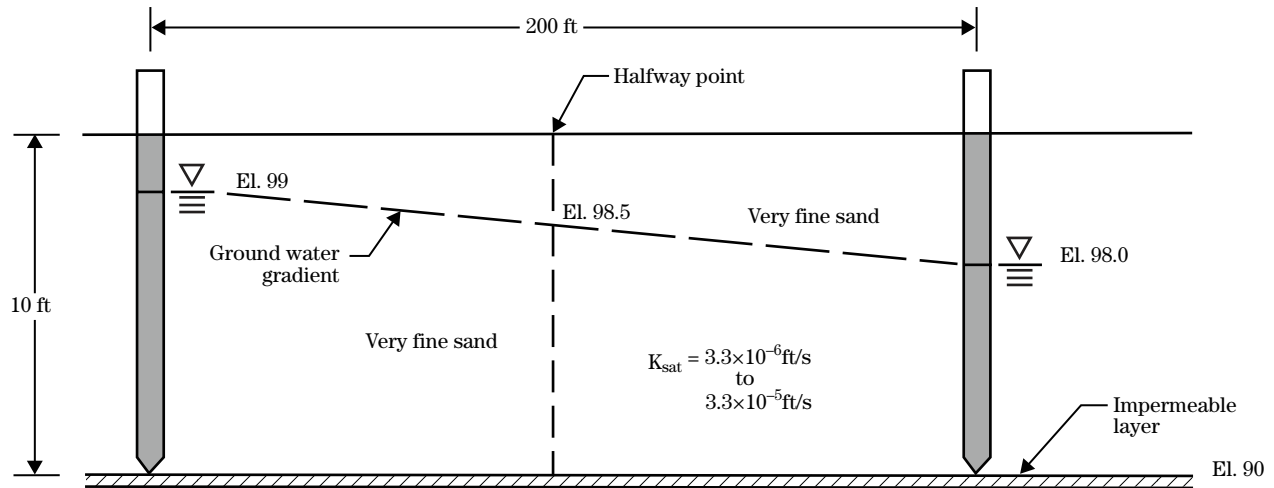
Example 13-1

Using equation 13-6, an estimate of the volume of flow can be made with the illustrated well data. The hydraulic gradient is found with equation 13-7:

$$Q = KiA$$

$$i = \frac{\Delta H}{\Delta L}$$

$$\Delta H = 99.0 - 98.0$$

$$= 1.0 \text{ ft}$$

(eq. 13-7)

$$\Delta L = 200 \text{ ft}$$

$$i = \frac{1}{200}$$

$$= 0.005$$

The area is the average area between the ground water surface at each well and the bottom of the permeable layer and is computed per unit foot of vertical flow area.

$$\frac{((99.0 - 90.0) - (98.0 - 90.0))}{2} = 8.5 \text{ ft}^2/\text{ft}$$

For the maximum K_{sat}

$$Q = (3.3 \times 10^{-5}) \times 0.005 \times 8.5$$

$$= 1.4 \times 10^{-6} \text{ ft}^3/\text{s}/\text{ft}$$

For the minimum K_{sat}

$$Q = (3.3 \times 10^{-6}) \times 0.005 \times 8.5$$

$$= 1.4 \times 10^{-7} \text{ ft}^3/\text{s}/\text{ft}$$

Example 13-1—Continued

For a flow boundary of 1,500 feet, and converting to gallons per minute:

$$\begin{aligned}Q_{\max} &= 1.4 \times 10^{-6} \times 1500 \times 40 \\ &= 0.95 \text{ gal/min}\end{aligned}$$

Q_{\min} is 0.1 gallons per minute.

This example makes the following simplifying assumptions:

- The impermeable layer prevents any significant vertical flow, so the flow is essentially horizontal.
- The K_{sat} is truly a horizontal saturated hydraulic conductivity and is homogeneous throughout the profile and from well to well.
- The wells are located on the horizontal direction of the ground water flow lines.

From the previous example, it can be seen that the main source of uncertainty is the determination of K_{sat} . The installation of more wells can provide more confidence in the results. The design of a monitoring plan must be done carefully to obtain the highest quality of data. In some cases, a good measurement of the flow rate into the wetland can be obtained for a check on the K_{sat} value.

Pumped water (P_i and P_o)—The volume of water pumped into (P_i) or out (P_o) of a wetland can be determined from the use and capacity of the pump. Information on the design of pumps and pumping plants can be found in NEH, Section 15, Chapter 8, Irrigation Pumping Plants (fig. 13–20).

Tidal flows (T_i and T_o)—Estuarine fringe HGM wetland types have a hydrology dominated by tidal inflows and outflows. This chapter does not include riverine wetland types where the stream hydrograph is influenced by tidal action. In these systems, no other hydrologic inputs are significant.

The forces that affect these systems are the tide stage and volume of water moving in and out of the wetland. Tide stage is based on the predictable and cyclic rise and fall of ocean surface due to the gravitational forces of the moon and sun and other factors such

as wind speed and direction, tilt of the Earth's axis, et cetera. Tides in most locations are semidiurnal, which means that there are two high tides and two low tides on a daily basis. The magnitudes of the two high tides are usually different, as are the magnitudes of the low tides. The average highest semidiurnal tide is referred to as Mean Higher High Water (MHHW), and the average lowest semidiurnal tide is the Mean Lower Low Water (MLLW). These tide stages help determine the hydrologic regime of the wetland, but are not the sole determinant.

The volume of T_i and T_o is defined as the tidal prism. This is the amount of water entering the wetland between the lowest water elevation due to tidal outflows and the highest water elevation entering the wetland due to tidal inflows. Wetland water budget analysis focuses almost exclusively on the tidal prism. It is important to note that the highest stage of the tidal prism is not necessarily the highest tide stage. This occurs as the tide reverses before the wetland level reaches the high tide stage.

Sea water moves into and out of estuarine wetlands through tidal channels and as sheet flow between channels. The geometry of these channels determines the majority of the flow rate during the tide cycle and, thus, the volume of the tidal prism. Tidal channels in a sustainable estuarine wetland system are in dynamic equilibrium with sediment movement in and out, the tidal prism, and the channel hydraulics. The tidal prism increases if the capacity of the inlet channel or channels is increased. However, this increased tidal prism may cause increased stress on the channel cross section, causing more channel material to move out of the wetland than is deposited during inflows and causing channel erosion. In systems where significant subsidence has occurred, restoring tidal access can cause wave erosion. The designer may consider leaving existing dikes in place between breaches at the tidal channels to mitigate against wave erosion. In most cases, total removal of existing dikes is not necessary to restore wetland hydrology.

Stored surface water (S_d)—The volume of stored surface water (S_d) can be determined from a stage storage curve developed from a topographic survey of the wetland. In simplified water budget analyses, S_d is often determined in terms of the depth of water stored over the wetland surface. The other water budget terms must also be determined in terms of depth.

Figure 13–20 Hydrology enhancement with pumped ground water



For instance, in a High Plains playa, the runoff over the watershed, direct precipitation, seepage out of the wetland, and storage can all be expressed in inches and used to determine the hydroperiod and hydrologic regime. The use of a drainage area to playa size ratio must be applied to the runoff depth.

Stored pore water (S_p)—The water storage capacity is the volume of water stored in the void spaces of the wetland soil matrix between the saturated condition and the soil water content at the driest part of the hydroperiod for the depth of the profile subject to water content changes. The saturated water content per unit volume is usually expressed as porosity, η , the ratio of the volume of soil voids divided by a unit volume. Porosity can be determined by a laboratory analysis.

An estimate of porosity can be determined if the soil's *in situ* dry density is known. The dry density can be determined by using the procedure "Inplace Moisture-Density Determination: Calibrated Cylinder Method" found in the NEH, Section 19, Construction Inspection. This requires the use of a calibrated drive cylinder, driver, and drying oven. It is also necessary to assume the specific gravity, G_s of the soil solids. Specific gravity is the ratio of the soil grain density to the density of water and has a relatively small range of values for most soils. If this value is unknown, a value of 2.65 is a good estimate for mineral soils. Example 13-2 shows the soil volume-weight relationships and determination of soil porosity from a known dry density and assumed specific gravity for a unit volume of 1 cubic foot.

Example 13-2

Known: Dry density (γ_d) = 85 lb/ft³

Assume: Specific gravity, G_s , = 2.65

Find: porosity, η

Step 1 Determine the volume of soil solids, (V_s) and volume of the voids (V_v).

$$\begin{aligned} V_s &= \frac{\gamma_d}{G_s} \times 62.4 \\ &= \frac{(85)}{(2.65 \times 62.4)} \\ &= .51 \text{ ft}^3 \\ V_v &= 1 - V_s \\ &= 0.49 \text{ ft}^3 \end{aligned}$$

Step 2 Determine porosity.

$$\begin{aligned} \eta &= \frac{V_v}{V} \\ \eta &= \frac{0.49}{1} && \text{(eq. 13-8)} \\ &= 0.49 \end{aligned}$$

V = unit volume of 1 ft³

Total stored pore water is a function of the profile depth and porosity. The profile depth used is the average depth where the soil moisture varies throughout the wetland hydroperiod. Below this depth, the soil moisture is usually assumed to be a long term constant. This depth is usually assumed to be the rooting depth of wetland vegetation, the depth to the least permeable soil layer, or the level of the lowest water table elevation during the hydroperiod. Water in this part of the profile is removed by water movement through the soil, evaporation from the surface, or transpiration through plants.

Finally, the moisture content at the low point of the hydroperiod must be assumed. Free drainage of soil will not remove 100 percent of the water in the soil voids. Capillary water is held in the soil against gravity and requires plant root tension to remove. The ratio of water removable by gravity in a unit volume of soil is called the drainable porosity, also expressed by the variable η . This parameter is often utilized in the analysis of wetlands where physical surface or subsurface drainage measures are being removed or modified.

The volume of soil water storage available is the difference between the drainable porosity and the total porosity for the depth of the soil profile. The drainable porosity is not a constant per unit depth. It decreases in a nonlinear fashion with increased depth of profile. The determination of drainable porosity values will require the services of a soil scientist or water management engineer.

Once free drainage removes water by gravity, wetland plants remove more water by tension through their roots. Determination of this removal amount can be done using soil-plant-water relationships. These parameters are used in irrigation engineering. The minimum amount of water storage is assumed to be a percentage of available water capacity (AWC). The AWC of a soil is the difference in volume between field capacity (FC) and permanent wilting point (PWP). FC is the maximum volume of water stored after free drainage due to gravity. PWP is the volume of soil water when plants begin to die due to dryness. In practice, the depth of the soil profile is assumed to be the rooting depth of the vegetation, and the ending stored soil water volume is assumed to be a percentage of AWC, commonly 50 percent. The soil will store the volume of water between this condition up to saturation before surface water appears on the wetland. The values for

available water capacity of a soil are usually available from state supplements to NEH, Section 15, Chapter 1, Soil-Plant-Water Relationships and are expressed as inches of stored water per foot of soil profile.

In practice, the procedure used is based on the type of wetland and assumptions of the total variation of soil water during the hydroperiod cycles. Many wetlands never dry to the point where water is removed from soil voids. In these cases, the change in S_p can be assumed to be 0. Slope wetlands are often supplied with a constant flow of ground water, which keeps the soil at a steady state of saturation. In other cases, such as High Plains playas, seasonal variations can be extreme. At the peak of the hydroperiod, the wetland may pond water above the soil surface. At the dry part of the hydroperiod, the soil may dry to the point where vegetation dies after soil moisture is removed to the bottom of the rooting depth by plant ET. Mineral flat wetlands often fluctuate only from saturated conditions to free drained conditions, which require the use of the drainable porosity parameter.

Example 13-3 shows the determination of the change in stored soil pore water, (ΔS_p) for a highly variable depressional wetland which saturates and then completely dries out down to the bottom of the plant root zone using the porosity and total storage found in the example 13-2.

Example 13-3

Known: $S_p = 0.49$ in/in (from example 13-1)
AWC = 3.5 in/ft
Plant community root depth = 3 ft

Assume: 50 percent depletion of AWC.

Find: ΔS_p in inches

Step 1 Determine S_p at minimum point of hydroperiod.

$$S_{p(\min)} = \% \text{ depletion} \times \text{AWC} \times \text{root depth}$$

$$\begin{aligned} S_{p(\min)} &= 0.5 \times 3.5 \times 3 \\ &= 5.25 \text{ in} \end{aligned}$$

Step 2 Determine S_p at maximum point of hydroperiod.

$$S_p = \eta \times \text{root depth}$$

$$\begin{aligned} S_p &= 0.49 \times 3.0 \times 12 \\ &= 17.64 \text{ in} \end{aligned}$$

Step 3 Determine change in S_p , (ΔS_p)

$$\begin{aligned} \Delta S_p &= 17.64 - 5.25 \\ &= 12.39 \text{ in} \end{aligned}$$

(ii) The hydroperiod—The hydroperiod is the seasonal pattern of the water level of a wetland. An analysis of the hydroperiod will determine the availability of water throughout the year; the extreme wet and dry conditions which can be expected; the extent of storage, drainage, and pumping which may be required for the proposed function; and the design of the water control facilities in the wetland. This analysis will identify limitations on wetland function associated with the water budget and potential management alternatives. The hydroperiod of the wetland can be determined from the data gathered for the water budget.

To achieve the desired goals of the hydrologic system, it may be necessary to manipulate the factors of the water budget. This may be achieved by the following methods:

- The volume of runoff inflow may be increased or decreased by diverting runoff water into or out of the wetland area.
- The rate of runoff inflow may be controlled by a water control structure upstream from the wetland.
- The rate and volume of runoff may be altered by changes in the land use and management of the contributing drainage area of the wetland.
- The baseflow into the wetland may be increased by diverting available water into the wetland.
- The evapotranspiration rate may be controlled by selection and management of vegetation and by windbreaks surrounding the wetland.
- The volume of water artificially supplied by pumping into the wetland can be varied.
- The volume of storage in a wetland can be altered by the construction of levees and water control structures.
- Excavation of deep pools or fill can increase or decrease water storage capacity.
- The volume of ground water outflow may be decreased by compaction of the wetland substrate.

(b) Hydrodynamics of wetland systems

The flow characteristics of a wetland describe the movement of water within the wetland system. Understanding and predicting the internal flow char-

acteristics can be critical to the restoration, enhancement, or creation of a wetland for a specific function. The hydrodynamics of a wetland is one of the factors in determination of HGM class. Each class has unique dominant water sources and direction of movement. Each of the HGM classes is included in the following discussion, along with the appropriate water budget parameters to use in a hydrodynamic analysis.

(1) Depressional systems

Depressional systems can be placed in two general categories. These are systems with a significant ground water component and those without ground water influence. Wetlands which have a significant ground water inflow are discharge wetlands, and those with significant ground water outflow are called recharge wetlands. The prairie pothole wetlands of the Northern Plains are an example of this type of depressional wetland. The analysis of the ground water flow is complex and will require the services of a ground water hydrologist. Discussion of this analysis is beyond the scope of this chapter.

Depressional systems with no significant ground water inflow typically exhibit a water table perched upon a low permeability soil horizon, which is separated from the local ground water table. These types are represented by High Plains playas, California vernal pools, and others. For these systems, the water budget can be expressed by the simplified equation:

$$\Delta S_s + \Delta S_p = (P_i + R_i) - (R_o + G_o + E + T) \quad (\text{eq. 13-9})$$

The individual parameters of the equation can be represented as volume in acre-feet or cubic feet. They can also be represented in direct depth, typically inches. If using volumes in terms of depth, a ratio of drainage area to basin area is employed. The analysis of these systems is further simplified using monthly data for rainfall, evaporation, and transpiration. Daily or weekly statistics for these parameters are generally not available.

The water budget terms, using monthly data and volumes expressed in depth, are described:

ΔS_s is the basin storage, in inches of depth. As stated previously, the analysis must include the ratio of drainage area versus basin area. The analysis must also include the maximum depth of storage before surface water leaves the basin as overflow. Surface storage is

determined by a stage-storage curve developed from topography. When using storage in terms of depth, the storage volume must be divided by the surface area to determine the equivalent depth.

As stated, ΔS_p is the inches of available storage in the soil pore spaces. The analysis typically assumes that this storage is filled before water begins filling the basin surface storage volume. Values for AWC are available from state supplements to NEH, section 15, Chapter 1, the published soil survey, or the Web soil survey at <http://websoilsurvey.nrcs.usda.gov/app/>.

P is the direct precipitation on the basin and drainage area. This value is available as a monthly statistic on the WETS table. The WETS table is available from the National Water and Climate Center at <ftp://ftp.wcc.nrcs.usda.gov/support/climate/wetlands/>.

R_i is the surface runoff resulting from the monthly rainfall totals (P). The NRCS RCN method of estimating runoff is based on an individual rainfall event. Runoff analysis is described in 650.1304(b)(3)(i).

R_o is the runoff out of the basin once the maximum storage depth is reached. This can be changed by physically raising or lowering the outflow elevation with grading or water control structures.

G_o is the seepage loss through the wetland substrate. The parameter that governs the loss of water vertically downward through the soil profile is the saturated vertical hydraulic conductivity (K_v). The published soil survey or Web Soil Survey provides values for this parameter. However, the water budget analysis is especially sensitive to this parameter, and the published range of values is very wide. Fortunately, the measurement of vertical hydraulic conductivity is relatively straightforward with standard permeameter devices. For information on setting up and performing a field permeability test, contact the Wetland Hydraulic Engineer, National Wetlands Team, Fort Worth, Texas, or the Soil Mechanics Engineer, National Design, Construction, and Soil Mechanics Center, Fort Worth, Texas. The relationships between soil type, compaction, and hydraulic conductivity data is treated in appendix 10D (Agricultural Waste Management Field Handbook).

E is the evaporation from an open water surface.

A water budget analysis can be readily accomplished using spreadsheet methods. An example is shown in figure 13–21.

(2) Riverine systems

Riverine wetlands are formed and maintained by the presence of a stream and exist in the original stream flood plain. The hydrology of these wetlands may be supported by out of bank flow or by a ground water level dependent on the stream's water surface profile, or both. Some riparian wetlands may have hydrology supported by surface runoff from uplands only, especially where the stream has a deep, incised channel and the soils have low permeability. The water budget analysis for these areas is the same as depressional wetlands. It is important to note, however, that a restoration of the stream corridor includes the restoration of the riparian wetland system. These restorations should be planned and implemented using the guidance found in NEH 653, Stream Corridor Restoration and NEH, Stream Restoration Design.

(i) Hydrology

Surface water—The hydrology of the system is defined in terms of the stream's hydrograph. The restored stream will provide out of bank flows and/or maintain a ground water table with a frequency sufficient to support flood plain wetlands. Out of bank flow rates are those which exceed the **geomorphic bankfull discharge, channel-forming discharge, or dominant discharge**. This discharge is that with a return period frequency from 1 to 3 years normally, and is often equated to the 2-year peak discharge. It is also the discharge which maintains a stable channel. Guidance on determining this discharge can be found in NEH, parts 653 and 654. Many areas of the county have regional curve reports developed which define the bankfull discharge return period and discharge rate versus drainage area. Streams that do not provide out of bank flows onto their original flood plain during this discharge may be considered for restoration to restore these flood flows.

Ground water—The ground water surface of riparian wetlands may be perched on low permeability soils in the flood plain and found significantly above the actual stream ground water surface. In this case, the stream hydrology and wetland ground water table are disconnected. The ground water conditions are the same as for depressional wetlands.

Figure 13–21 Simplified water budgets can be readily analyzed using spreadsheet tools

Wetland and Water Budget Spreadsheet

Landowner: _____ Practice: _____
 NRD: _____ Designed: _____ Date: _____
 Field Office: _____ Checked: _____ Date: _____
 Approved: _____ Date: _____

Wetland Info:
 Converted wetland currently in agricultural production, excess water drained away

County: Cont. DA CN₁ = CN₃₀ = 67

Estimated Max. Deep Percolation = Inches/Month Overflow Height = Inches
 Estimated Water Holding Capacity = Inches
 Ratio of Drainage Area:Basin Area = (runoff multiplied by this ratio to obtain runoff, surface inches)

Month	Precip (Inches)	Runoff (Inches)	Runoff (Sur. In.)	Other Inflow (Sur. In.)	ET Potential (Inches)	Sum (Inches)	Deep Perc (Inches)	Sum (Inches)	Outflow (Inches)	Balance (Inches)
										Starting= → -6.00
September	3.02	0.60	5.99		5.17	-2.16	0.00	-2.16	0.00	-2.16
October	1.67	0.08	0.85		3.76	-3.40	0.00	-3.40	0.00	-3.40
November	0.98	0.00	0.00		1.88	-4.30	0.00	-4.30	0.00	-4.30
December	0.85	0.00	0.00		0.94	-4.39	0.00	-4.39	0.00	-4.39
January	0.51	0.00	0.00		0.94	-4.82	0.00	-4.82	0.00	-4.82
February	0.70	0.00	0.00		1.41	-5.53	0.00	-5.53	0.00	-5.53
March	2.08	0.20	2.01		2.35	-3.79	0.00	-3.79	0.00	-3.79
April	2.54	0.38	3.76		4.70	-2.19	0.00	-2.19	0.00	-2.19
May	4.77	1.65	16.51		5.64	13.45	0.50	12.95	0.00	12.95
June	3.94	1.11	11.13		6.58	21.45	0.50	20.95	0.00	20.95
July	3.43	0.82	8.16		7.05	25.48	0.50	24.98	0.98	24.00
August	3.32	0.76	7.55		6.58	28.29	0.50	27.79	3.79	24.00
Total	27.8	5.6	55.96	0.00	47.00	58.1	2.00	56.1	4.77	

Soils Info:

	Depth	AWC	Description
Fillmore, Clay County NE	0 - 19 in.	3.99	hydric
	19 - 33 in.	2.94	hydric
	33 - 45 in.	1.8	hydric

Design Info:

Precipitation and Runoff are monthly 50 percent chance events.

Et ~ 1.0 pan evaporation initial conditions, may be modified depending on location

Created by Geoff Cerrelli, Civil Engineer USDA/NRCS Harrisburg, PA (717) 237-2215

Modified by Jacob Robison, Civil Engineer USDA/NRCS Grand Island, NE

Additional weather data at www.wcc.nrcs.usda.gov/cgibin/getwetco.pl?state=ne

The riparian wetland ground water surface may be directly connected to the stream water surface profile. In high permeability flood plain soils, a change in stream water surface translates quickly to the flood plain wetland. In these cases, the stream will support wetland conditions with no out of bank flows if the stream water surface profile is sufficiently high.

(ii) Hydraulics—The stream's hydraulic characteristics are determined by its **channel geometry**. Channel geometry parameters include bankfull width, bankfull depth, channel slope, flood plain slope, sinuosity, and Manning's n value. Hydraulic analysis can be done simply by using cross-sectional data and Manning's equation or by analysis of the stream's water surface profile along a reach using the USACE HEC-RAS program. The WinXSPro program is a simple channel cross section analyzer that can quickly develop a stage-discharge table from an input cross section and Manning's n value.

Flood plain features—Active flood plains exhibit many complex features such as oxbows, chutes, scour channels, natural levees, and backwater areas. Flood plains that are no longer active (flooded during geomorphic bankfull discharge) may still exhibit remnant flood plain features with wetland hydrology due to surface runoff and ponding. These features can provide valuable wetland functions and should be considered for restoration. Flood plain features subject to flooding are dynamic systems and should be designed for a minimum level of management. Constructed dikes, levees, and water control structures are problematic and typically hinder the function of the wetland. Flood plains no longer subject to flooding can include constructed features for restoration or enhancement of wetland hydrology.

(iii) Design alternatives

Incised channels—Riparian wetlands that have been altered due to channel incision are common throughout the country. The incision results in an increase in channel capacity to the point where out of bank flows no longer occur with the frequency needed to support wetland hydrology. There are three basic options to restoration. The first is to concentrate on the flood plain wetland area with no attempt to restore the channel. The wetland is treated as a depressional wetland and must support wetland hydrology with surface runoff and ponding. Construction of dikes and water control structures is appropriate to re-create the hydroperiod formerly provided by stream flooding.

The second option is to raise the stream water surface profile by installing grade stabilization structures, filling the channel, or both. It is critical to ensure that the upstream effects do not extend beyond the project boundary. This option is most appropriate where the channel has incised in place, without channel straightening. The grade stabilization structures should be full-flow, open structures and spaced close together to prevent excessive water surface profile drop between structures. The drop is typically held to about 1 foot between structures. Careful attention is given to the downstream structure where the profile is returned to the incised channel. Interruption of sediment transport caused by the new structures can cause grade loss downstream of the project.

The third option is a complete meander reconstruction of a new channel with the appropriate width, depth, slope, and sinuosity to restore horizontal connectivity with the flood plain wetlands. The services of a trained fluvial geomorphologist should be obtained. Guidance in planning is available in NEH, Part 653, Stream Corridor Restoration, and guidance in design is available in NEH, Part 654, Stream Restoration Design.

Denuded channels—These wetlands have been altered by the loss of streambank stability. The channels usually have hard, immovable beds, which preclude grade loss. The banks typically have eroded because of the removal of riparian wetland vegetation due to clearing, grazing, channel straightening, flow augmentation, or watershed modifications. Usually, the wetland hydrology still exists, and restoration focuses on reestablishing wetland vegetation. In many cases, livestock exclusion is all that is necessary. Soil bioengineering measures are also appropriate to restore bank stability and wetland vegetation. Detailed information on soil bioengineering techniques is available in the EFH, chapter 18.

Diked or leveed streams—These wetlands have been altered by the presence of dikes adjacent to the channel, preventing flood flows from entering the flood plain. Typically, the original wetland hydrology was provided by these flood flows, and not by stream water surface profile induced ground water. Surface water from adjacent uplands is either diverted around the wetland or is transported through the flood plain, the dike, and into the channel through a conduit with a "flap gate." The flood plain may have remnant flood plain features.

In many cases, the dikes are part of a large flood control project and must be maintained. In these cases, restoration of the original wetland hydrology is not possible. The focus is in using other means to replicate this wetland's hydrology with other water sources including surface runoff.

If modification of the dike system is possible, the main restoration activity involves removal of the dike. Often, it is cost prohibitive to completely remove the dike and properly dispose of the fill material. Usually, flood flows can be allowed onto the flood plain by breaching the dike in one or more locations. The areas of dike removal must be carefully considered. A breach at the downstream end of the diked area will allow backwater to enter the wetland and minimize the danger of high velocity floodwater flowing through the wetland. Internal wetland structures can be maintained for water level control using this approach. An additional breach at the upper end of the area will allow flood flows to pass through the system. This approach can be utilized to allow the stream system to maintain a natural dynamic wetland with associated scouring, sediment deposition, and maintenance of flood plain features. Internal water level control structures are problematic using this approach, as they are subject to headwater flows through the flood plain.

A hydraulic analysis of the system is recommended when designing a dike removal project. The resulting change in the stream water surface profile at the upstream and downstream end of the project may create channel instability.

Figure 13–22 illustrates a schematic of a riverine wetland project incorporating a backwater breach of a levee.

A dynamic riverine project incorporating a headwater breach is illustrated in figure 13–23.

(3) Slope wetland systems

The general water budget equation for slope wetland systems is:

$$\Delta S_p = (G_i + P + R_i) - (ET + G_o + R_o) \quad (\text{eq. 13-10})$$

In a typical case, the steady state condition for a slope wetland is one where the slope wetland is a defined area where wetland vegetation exists in an area with

an obvious boundary, there is no surface discharge, infrequent rainfall events do not significantly contribute to the wetland's hydroperiod, and there is little change in the soil storage or ground water inflow throughout the season. These simplifying assumptions provide the equation 13–11:

$$G_i = ET + G_o \quad (\text{eq. 13-11})$$

A further simplifying assumption common to many slope wetlands is that the majority of the ground water inflow is forced to the surface by a layer of low permeability rock or soil. This water is then made available for transpiration by wetland plants or evaporation from the wet surface of bare soil. All of this water is utilized by the wetland vegetation. The equation then becomes:

$$G_i = ET \quad (\text{eq. 13-12})$$

Assuming that the ground water inflow is relatively constant, the volume of this flow will support a certain surface area of vegetation. If the ground water flow is diverted or otherwise reduced, the area which will support wetland vegetation will shrink. Restoration is usually focused on eliminating or reducing the amount of diverted ground water inflow. The ET of the system can often be assumed to be the PET expressed as the FWS evaporation or lake evaporation available from the NOAA reference provided in NEH650.1304 (a)(3), Evaporation and Transpiration. If the current diversion is a spring development for the purpose of providing livestock water, the diversion rate can be expressed in terms of animal units (AU). Example 13–4 shows a slope wetland water budget analysis on a monthly basis for a quarter-acre slope wetland.

Another restoration practice is to modify the conditions of the watershed that provides the ground water inflow. Ground water is provided by precipitation on a "ground water watershed." Unlike surface runoff, it is usually difficult to define the exact boundaries of this ground water catchment area. However, if an improvement in watershed conditions can be accomplished over a large land unit which includes the small area of the wetland's ground water catchment, an increase in ground water inflow will result, even though it is difficult to quantify. A common case is the reduction or elimination of deep rooted woody vegetation in pasture or rangeland and the increase in shallower rooted herbaceous cover.

Figure 13-22 Schematic of a riverine wetland project incorporating a headwater breach of a levee

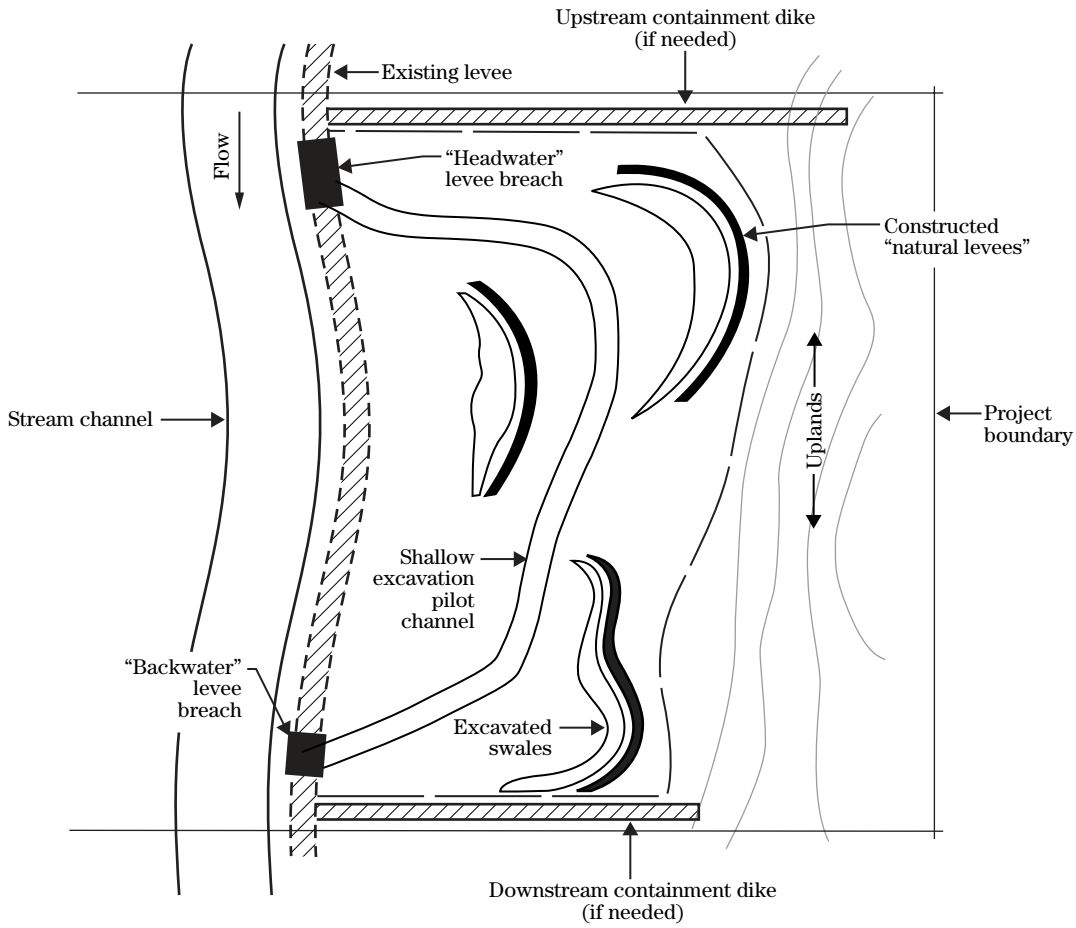
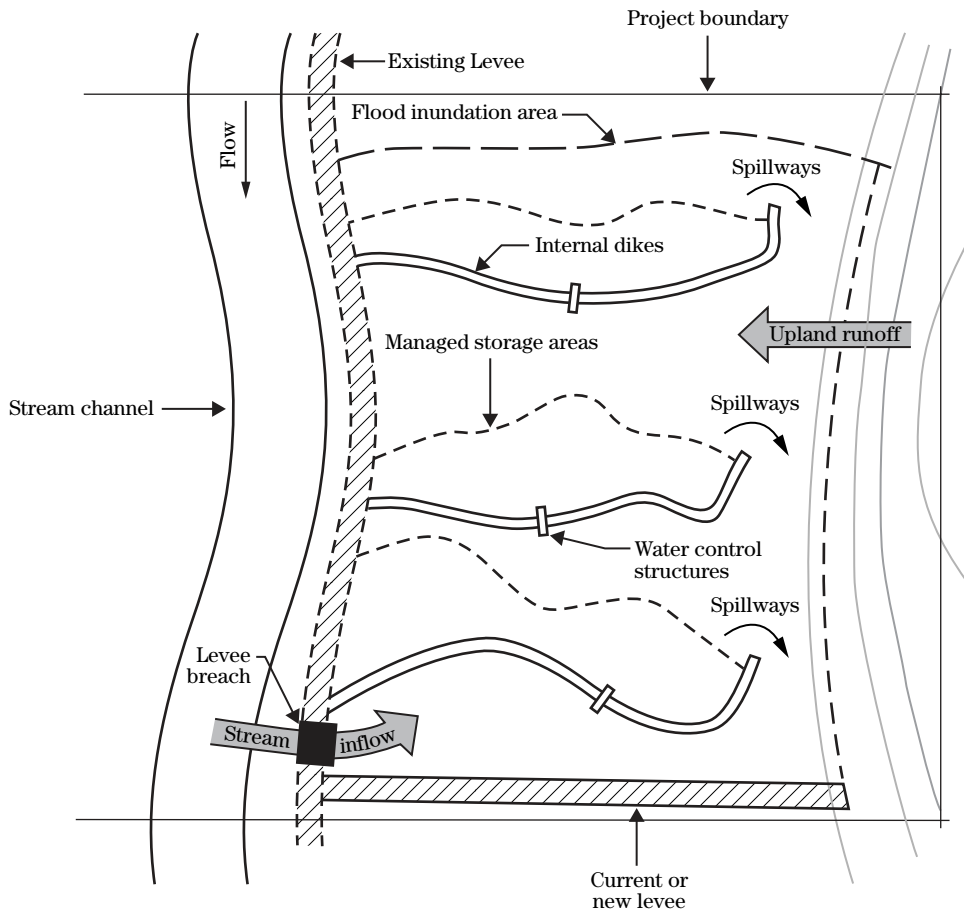

Figure 13-23 Dynamic riverine project incorporating a backwater breach



Example 13-4

Average daily PET for the month of June: 0.25 in/d

Water use per AU = 15 gal/d

Flow rate of water use per acre of wetland =

$$(0.25 \text{ in/d}) \times (450 \text{ gpm/ac-in/h}) \times (24 \text{ h/d}) = 2,700 \text{ gal/d}$$

For a one-quarter-acre wetland the ET use is:

$$0.25 \times 2,700 = 675 \text{ gal/d}$$

For this example, the local functional assessment allows a reduction of 10 percent of the wetland inflow for a “minimal effect” on the wetland function. This allows 67.5 gallons per day to be used for livestock water. In terms of stocking rates:

$$\frac{(67.5)}{15} = 4 \text{ AU}$$

The wetland restoration would then provide for a stocking rate for livestock that did not exceed an average of four animal units for the water source.

(c) Design of structural components

Structural components are used in wetland restoration, creation, or enhancement for many reasons. They create or increase storage capacity. They divert water into, out of, or through wetlands. They serve to protect embankments from overtopping during runoff events. Structures are used to manage water levels to improve wetland functions. They provide passage for fish and other aquatic organisms. It is important to remember that design of each structure must be done in accordance with the appropriate CPS and the associated purposes and criteria. These CPSs include Dike, Grade Stabilization Structure, Structure for Water Control, Pond, Pumping Plant for Water Control, and others. These components have their own separate criteria for design storms, capacity, and structural design. It is common for the component criteria to exceed the 10-year, 24-hour storm runoff criteria for the Wetland Restoration, Creation, or Enhancement CPSs. It is also important to consider the potential hazard associated with failure for each of these components.

(1) Dikes and levees

The following information applies to dikes considered to be Class III dikes according to the FOTG Standard-Dike, with low hazard class. Both dikes and levees shall be referred to as dikes.

Dikes are embankments of earth constructed to contain water. Dikes constructed for wetland restoration, creation, or enhancement fit into two broad categories. The first is a dike constructed to prevent stream, lake, or tidal flooding from entering the wetland project area. The use of a dike for this purpose is most appropriate when the wetland project is part of an existing flood control system where adjacent nonproject areas must have continued flood protection. The second category is where dikes are constructed to restore or enhance wetland hydrology by storing and controlling water provided by direct precipitation, surface runoff, or stream flooding.

Planning and design of new flood protection dikes must be conducted with extreme care. These dikes can raise the stream floodwater surface up and downstream of the wetland project, increase flood velocities, and interrupt the lateral connectivity between the flood plain and stream for aquatic organisms.

The following guidelines and procedures apply generally to dikes constructed in rural or agricultural areas where minimum damage is likely to occur from dike failure, and the maximum design water stage against the dike is 6 feet for mineral soils and 4 feet for organic soils. Channels, sloughs, swales, and gullies can be excluded in determining the design water stage in accordance with the FOTG.

Causes of dike failure are overtopping, undermining, sloughing, piping, or seepage along water control structures placed through the dike. The design of the dike should eliminate these dangers as much as possible. Since dikes usually are long and differences in soil conditions normally exist along the route, adjustments may be needed in the design section and construction methods for the different soil conditions.

Locating the dike away from a channel or excavation so that it will not be scoured by high velocities will protect against undercutting. Piping and erosion potential along conduits should be controlled by using a filter drainage diaphragm or antiseep collars installed according to the requirements found in NHCP Standard 378—Pond. When pumps are installed, the pump discharge pipe should be located over the top of the dike. If it is placed through the dike, the pipe should be placed above the design water surface, and the connection between it and the pump should be made with a flexible coupling to reduce vibration. Consideration should be given to the installation of an antisiphon device.

In the design of fills, consideration should be given to the moisture conditions of the fill and foundation soils at the time the fill is placed and to the method of construction. Ideally, stable fills are constructed of moist soil placed in layers 8 to 12 inches thick and traversed with the hauling equipment or otherwise compacted with a roller or other compacting equipment. The moisture content of fills should be controlled to the extent possible to maximize the in place fill density. Refer to NEH, Section 19—Construction Inspection for a discussion of compaction and the measurement of fill density. In general, placing fine-grained soil at a moisture content wetter (or much wetter) than the optimum moisture content results in a safer fill than placing material that is much dryer than optimum. Dikes constructed of fill that is much dryer than optimum

can suffer from piping failures during the first filling of the pool, as the large macropores in the dry fill matrix allow water to force their way through the fill before the fill matrix moistens. Dry fills of ML material can also experience sudden settlement upon wetting under certain conditions. Placing soils much wetter than optimum will result in lower than the maximum Proctor density (NEH, section 19), but the danger of a piping failure is reduced. The low strength of the resulting soil will usually not result in serious settlement and slope stability problems in fills less than 6 feet high. In most fine-grained soils (CL, CH, ML, and MH) a moisture content low enough to allow construction equipment to place fill in lifts, finish slopes, and not leave deep ruts will result in a safe fill on low dikes. For fills higher than 6 feet, the moisture and density control of the dike becomes more important. These fills should be placed in accordance with the minimum requirements in NEH, Section 20, Construction Specifications, Specification 23, Earthfill, Class C Compaction. An effective means of mitigating problems with wet soil compaction, strength, and slope stability is to provide flatter side slopes. Soils of OL material or soils with high organic content should be avoided. These soils, when removed from saturated conditions, will lose organic matter content through mineralization due to aerobic decomposition. Even when saturated, they will exhibit high levels of settlement and consolidation.

Where design water stages are of long duration and heavy waves are expected or where rapid lowering of the stage is possible, flatter side slopes and special protection for the waterside of the dike may be required. This special protection is important where the fill is of low plastic or noncohesive soils.

The first step after the tentative dike location has been made is to determine the design high water stage (H_w), based on frequency of the design storm and the duration of floodwater or storm tide stages.

(i) Dikes for flood control adjacent to streams and shorelines—Determination of H_w for flood control dikes is based on the water surface profile for the required return period event from stream flooding, lake stage, or high tide elevation, as appropriate. Records of flood stages and dates generally are available from the USACE, U.S. Coast Guard stations, municipal and port authorities, and the Coast and Geodetic Survey of the U.S. Department of Commerce. The latter issues annual editions of “Tide Tables—East

Coast” and “Tide Tables—West Coast.” Localized information may be obtained from landowners, recreational groups, or other sources. Storm tides resulting from hurricanes can, in the absence of records, be assumed to last about 75 hours along the southern and eastern coasts. However, actual records should be used where available.

Data for stream peak discharges can be found at the data sources provided in EFH650.1304(a)(3)(i). Where information on flood stages of streams is not available, use the techniques provided in NEH630.13, Stage Inundation Relationships.

Where dikes restrict flow in a flood plain, it is especially important to determine the stage for the design discharge after installation of the dike. If the flood plain on one side of a stream is to be protected by a dike, it will be necessary to find out if inundation of the unprotected land upstream, downstream, and on the other side of the flood plain will increase in depth, duration, and extent. An increase in water surface profile caused by dike installation will usually require obtaining easements on the affected property. In many areas, the flood plain is covered by the National Flood Insurance program, and flood maps have been developed with assistance from FEMA. Determination of the resulting water surface profile can be done by developing a HEC-RAS model.

High stages along coastal areas result when high daily tides are increased by high winds and waves. High wind tides can be expected several times annually in some areas. Hurricane winds along the Atlantic and Gulf coasts sometimes cause high water stages along the shorelines of freshwater lakes and reservoirs in the region. These also should be considered in design.

(ii) Dikes for internal water control and storage—For dikes designed to store and control surface runoff, dike height is based on the need to handle the runoff hydrograph for the design storm. If there is no drainage area to produce an inflow storm hydrograph, the height is based on the required hydrologic regime of the wetland. The entire storm runoff hydrograph volume may be stored behind the dike for controlled release, or reservoir routing methods may be used. Reservoir routing should be done in accordance with the criteria found in NHCP Standard 378—Pond. In cases where the dike crosses an unstable channel (gully) and failure of the dike will allow gully advance or

if dike failure will result in a grade control problem, the hydrologic and hydraulic criteria found in NHCP Standard 410—Grade Stabilization Structure should be used.

The design height of the dike (H_d) will be the sum of H_w , the added height (H_v) for wave action, if any, and the freeboard (H_f) (fig. 13-24). The constructed height will include an allowance for settlement (H_s), which will depend on the foundation and material used in construction. Freeboard (H_f) is the allowance added to the selected flood stage without the inclusion of wave heights. Criteria for settlement and freeboard are found in the FOTG Practice Standard—Dike.

(iii) Wave height—Wave height (H_v) allowances should be based on the best local experiences or computed by an acceptable formula. Table 13-4 may be used for open water reaches of less than 2,000 feet. The Stephenson formula with the Gaillard modification may be used in cases where the fetch length is greater. The use of the Stephenson formula is detailed in NEH, Section 11, Drop Spillways.

To convert the Stephenson wave height, H_v , to a H_v above high water stage, Gaillard suggests that it be modified as in equation 13-13:

$$\text{Modified wave height (ft)} = H_v 0.75 \quad (\text{eq. 13-13})$$

It is recommended that where waves are expected to have appreciable velocity, resulting in a run up the dike, the Stephenson formula be used to provide a reasonable degree of safety.

Vegetative growth between the dike and open water, if sufficiently high and dense, will tend to reduce wave heights. In such instances, allowances in (H_v) can be made. Such allowances should be based on plant growth and permanence of the stand and condition.

A wave berm or “beaching berm” is effective in dissipation of wave energy. Wave berms should slope toward the water at a 12H:1V ratio and should extend at least 2 feet above the average wetland operating level and at least 1 foot below.

Table 13-4 Additional height for wave action

Fetch (ft)	Wave height, H_v (ft)
1,001–1,250	0.2
1,251–1,500	0.4
1,501–1,750	0.6
1,751–2,000	0.8

Figure 13-24 Section through dike

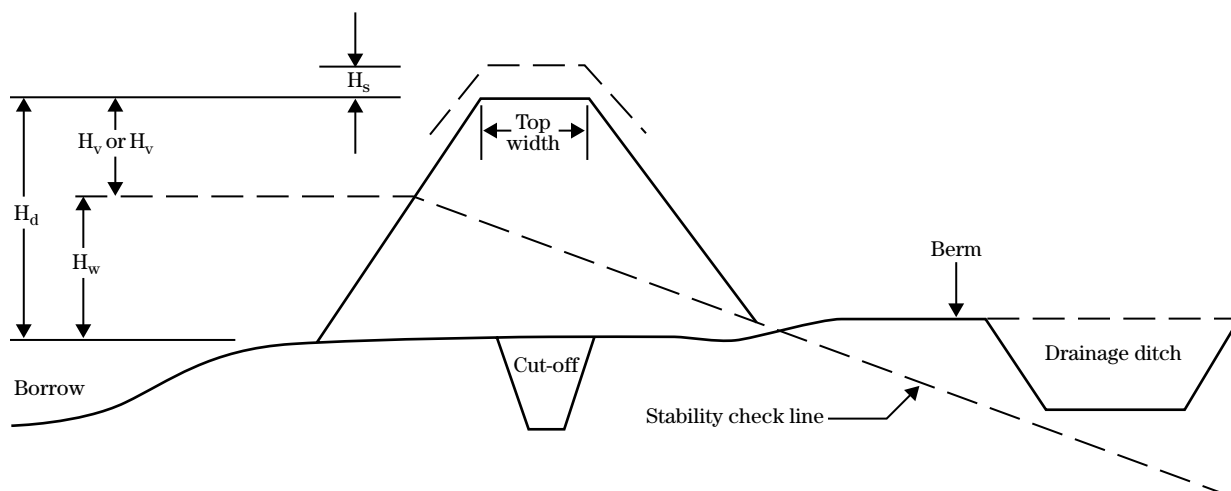

(iv) Design height—In the case where wave height is not determined, the design height is the sum of the design high water stage, H_w , and the freeboard, H_f . When wave height is calculated, the design height is the sum of H_w and H_v (fig. 13–24).

(v) Settlement allowance (H_s)—In fills placed near optimum moisture condition with firm foundation conditions and using Class C or better compaction methods, a settlement allowance of 5 percent of the dike height is appropriate. For soils placed much dryer or wetter than optimum, fills with high organic matter content or other adverse conditions, provide no less than 10 percent increase in height for settlement. In cases where the fill is placed with excavators with no compactive effort, use a 20 percent allowance. In cases where the use of organic soils is unavoidable, provide 40 percent allowance for settlement, and provide at least 6 inches of mineral soil cover to minimize aerobic decomposition.

(vi) Dike materials—Dikes usually are constructed of fill material borrowed from areas parallel to the line of the dike or from the planned wetland basin. In cases where borrow will parallel the dike location, investigations for foundation and borrow can be combined. It may be necessary to use borrow pits outside the immediate area and transport fill material to the site. If unstable soil conditions are found, it may be more economical to change the dike location rather than employ the costly construction methods required by the use of unstable soils.

For preliminary investigations, table 13–2 will assist in evaluating soil conditions along the line of the dike and can be used as a guide to soil stability and permeability.

Simple field tests can be used to classify the soil according to the procedures outlined in EFH Chapter 4, Elementary Soils Engineering. This information along with knowledge of engineering behavior characteristics may provide enough information to design stable low dikes in most average soil conditions. Figure 13–25 shows a dike built for internal water control.

(vii) Cutoff trench—Foundation cutoff trenches shall be installed according to the minimum criteria found in the NHCP Standard—Dike. The cutoff trench should be deep enough to extend into a relatively im-

pervious layer or to provide piping stability when combined with drainage or other seepage control. The bottom width should be adequate to accommodate equipment for excavating, placing, and compacting the fill. Backfill the trench with relatively impervious material or soil that has low permeability.

(viii) Dike stability—Unprotected subsurface drains are not normally permitted to be closer to the landside toe of the dike than a distance equal to three times the design water height. If subsurface drains are to be installed or to remain closer than this distance, they should be enclosed in a designed filter as a toe drain. Properly designed drain pipe within the specified distances from the dike may be laid instead of a drain.

Where a dike crosses an old channel, the base of the dike should be widened on the landside. The additional width should be at least equal to the height of the dike above normal ground elevation. The top of the extended base should be no less than 1 foot above normal ground and should slope away from the dike to provide for the runoff from the dike. The side slope of the extended fill should be no steeper than the landside slope of the dike. Such an extension of the base of a dike is known in certain areas as a banquette (fig. 13–26).

Figure 13–25 Dike for internal water control



The use of highly permeable soil in the dike should be avoided when possible because of potential leakage and piping. Where highly permeable soil is used in the dike fill, especially over a more slowly permeable foundation, the landside base of the dike may need to be extended or a toe drain provided to increase the dike's stability. The phreatic line should be contained within the embankment cross section. The additional width for drainage may be provided in the manner shown in figure 13-27.

Where existing foundation materials are inadequate to support the dike, a geotextile material may be used to replace or reinforce portions of the foundation. This may be an alternative to removing existing material and re-compacting or replacing it with borrowed material. Geotextiles consist of either two-dimensional grids or three-dimensional webs. They are made of many types of materials and by many different manufacturers.

Figure 13-26 Use of a banquette at a channel crossing

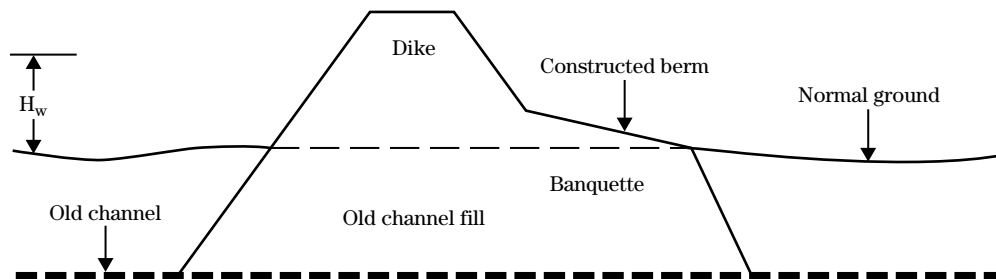
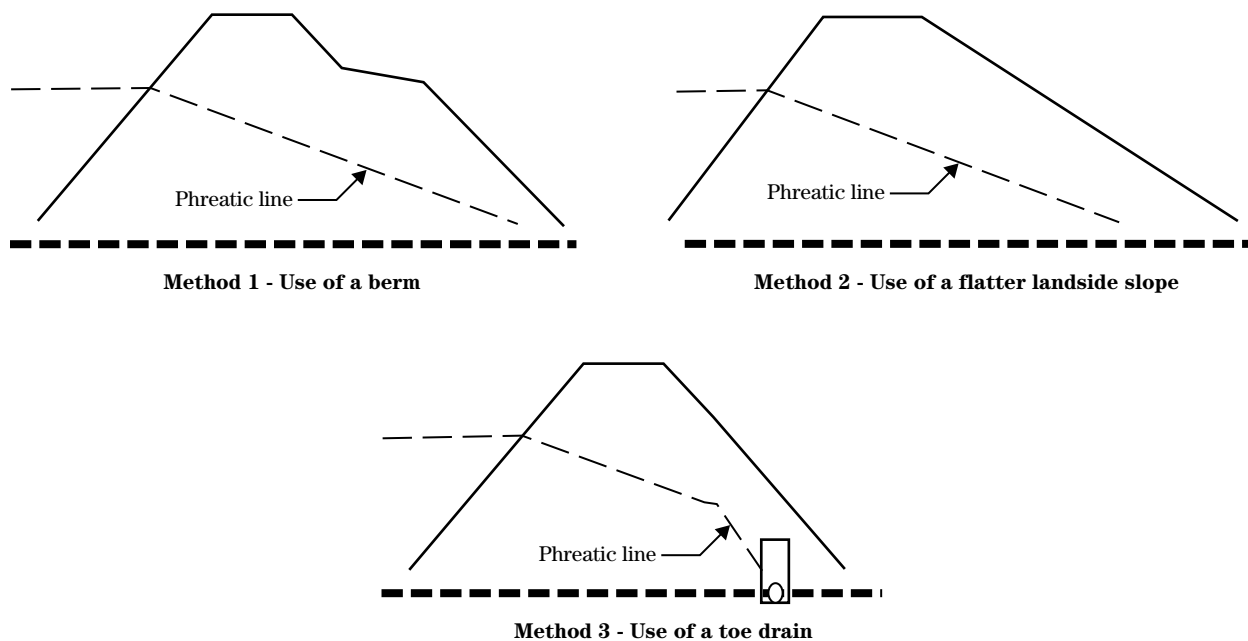

Figure 13-27 Methods of increasing the stability of a dike



Berms—If borrow (borrow ditch or channel) is excavated parallel to the line of the dike, the berm which separates the dike from the borrow should be wide enough to protect the toe of the dike effectively. When the foundation materials are noncohesive or highly permeable, the width of the landside berm should be increased to prevent piping along the face of the interior channel. Such piping along the channel could cause the berm to erode and slump, thereby undermining the dike.

For dikes where the design water depth is more than 6 feet for short sections, the landside ditch borrow pit should be far enough away from the dike to ensure stability. A line drawn from the design waterline on the face of the dike through the landside toe of the dike should, when extended, pass below the ditch or borrow pit cross section.

If a dike has a narrow top width, the landside berm should be wide enough to accommodate a maintenance roadway during critical high water periods. This facilitates travel to all sections.

Some fibrous organic soils have a steep natural slump that cannot be shaped to the planned side slopes. In such cases, the dike should be built to the designed base width and the top widened to meet the steeper side slopes. The sides will slump to flatter slopes as fibrous material decays.

Additional freeboard shall be provided to contain waves for dikes having longer surface exposure (fetch) by adding the following amounts to the applicable freeboard given previously.

For fetches over 2,000 feet, use the modified Stephenson formula for total freeboard ($H_v + H_d$). In areas where dikes will be exposed to wave action for extended periods of time, additional slope protection or a berm at the water level may be required.

(2) Water control structures

Water control structures are used to manage water levels, pass storm event runoff, and divert water into or out of a wetland.

(i) Hydraulic design—Hydraulic design of wetland structures can be separated into two separate analyses. The first analysis is for storm event runoff, and the second analysis is for water level control and man-

agement. The two analyses use separate tools and assumptions.

Storm event runoff—For wetland systems that have a contributing drainage area, the peak discharges and volumes of runoff must be determined to ensure that the structures perform safely, without structural failure according to the criteria in the appropriate practice standard. The hydrology tools used are the traditional NRCS procedures for single event, return period storms. For drainage areas up to 2,000 acres, EFH, Chapter 2 procedures can be used. For drainage areas between 2,000 and 20,000 acres, Technical Release 55 (TR-55) methods are appropriate. Larger drainage areas require the use of Technical Release 20 (TR-20) methods. Reservoir routing can be done with the use of the WinPond or SITES computer software, as required by the drainage areas. Both computer programs will allow the user to input a user-defined stage-discharge table for principal spillways and auxiliary spillways. The Hydraulics Formulas computer program can be used to develop a stage-discharge curve for various structures including straight weirs and stoplog structures. For flat auxiliary spillways that do not have enough slope to develop critical depth, the designer must determine a stage-discharge relationship for program input. Grassed waterway design procedures can be used, or the designer can build a HEC-RAS computer program model and run a series of flows near the estimated peak auxiliary spillway discharge to find a unique stage for each flow.

In riverine systems, the hydrologic analysis may require that streamflow records be obtained to determine the design stream hydrographs. The hydrologic and hydraulic criteria for water control structures are found in the appropriate FOTG Practice Standards, which include Grade Stabilization Structure, Pond, Dike, Structure for Water Control, or Dam.

Water level control and management—The structure must be able to maintain the desired water level during baseflow conditions, draw down the wetland in the necessary time period for management, and raise or lower water levels as needed for the planned wetland functions. This analysis was covered in EFH650.1304(a)(3)(i), Water Budget. In wetlands with no significant contributing drainage area, the analysis focuses on handling ground water inflows and precipitation.

(ii) Structure selection—Different structure types have different abilities to manage water levels precisely or pass high capacity flows. A general guide for water control structure selection based on capacity and structure height is shown in figure 13–28. EFH, Chapter 3, Hydraulics, provides tools for analysis and design of water control structures.

Diversions, spring developments, or pump systems may be used to supplement inflow. Refer to EFH, Chapter 9, Diversions; Chapter 12, Springs and Wells; and Chapter 14, Water Management (Drainage) for further discussion.

In wetland restorations, consider designing the structure to mimic the slow drawdown associated with natural outflows to maximize wetland function. An example is maximizing the function of mud flats for wading and shore birds.

(iii) Buoyant forces—The analysis of buoyant forces is especially critical in wetland situations for the obvious reason that saturated conditions will probably exist to the top of the structure for at least part of the year. The buoyant force (F_b) acting on a structure is equivalent to the volume of structure (including the solid part) times the unit weight of water. The forces resisting buoyancy include the weight of the structure and the weight of any soil acting vertically downward on the structure. The weight of the soil is only the saturated unit weight (γ_{sat}), which is the saturated unit weight minus the unit weight of water (γ_w). Only the soil load acting vertically downward is considered. Thus, only the area of the horizontal projections of conduits, riser bases, et cetera, will have a vertical load. Example 13–5 shows the calculations for a buoyancy analysis for a corrugated steel riser with a circular concrete base. A factor of safety (FS) of at least 1.5 is recommended to account for unknown forces due to floating large debris or ice imposing horizontal forces not accounted for in the analysis.

Figure 13–28 Structure selection guide

		Discharge—CFS								
		10	25	50	100	150	200	400	800	1500
Controlled Head—Feet	4	Drop spillways or hooded inlet spillways				Drop spillways				
	8									Drop or chute spillways
	12									
	16	Hooded inlet or pipe drop inlet spillways								
	20					Monolithic drop inlet spillways				
	25									Chute spillways
	30									
	40	Pipe drop inlet spillways								
	80									

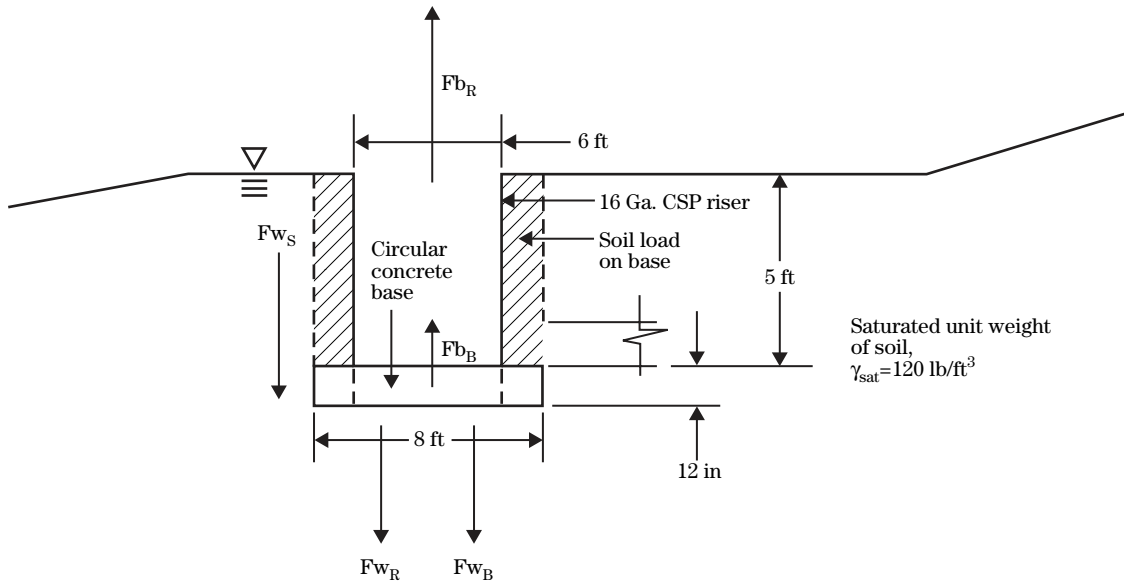
Example 13-5

Step 1 Find the buoyant forces on the riser, F_b .

F_b = the sum of the buoyant forces acting on both the riser, F_{b_R} and the riser base, F_{b_B}

$$F_{b_R} = VR \times \gamma_w$$

where:

γ_w = unit weight of water, 62.4 lb/ft³

$$\begin{aligned} VR &= \frac{\pi(6)^2}{4} \times 5 \\ &= 141.4 \text{ ft}^3 \end{aligned}$$

$$\begin{aligned} F_{b_R} &= 141.4 \times 62.4 \\ &= 8,823.4 \text{ lb upward} \end{aligned}$$

$$F_{b_B} = VB \times \gamma_w$$

$$\begin{aligned} VB &= \frac{\pi(8)^2}{4} \times 1 \\ &= 50.3 \text{ ft}^3 \end{aligned}$$

$$\begin{aligned} F_{b_B} &= 50.3 \times 62.4 \\ &= 3,138.7 \text{ lb upward} \end{aligned}$$

$$\begin{aligned} F_b &= 8,823.4 + 3,138.7 \\ &= 11,962.1 \text{ lb upward} \end{aligned}$$

Example 13-5—Continued

Step 2 Find the downward forces acting on the riser due to the weight of the components and the earth backfill over the base, F_w .

F_w = weight of the riser, F_{w_R} , weight of the base, F_{w_B} , and weight of the saturated soil backfill, F_{w_S}

F_{w_R} = height of the riser, 6 ft \times the weight per liner foot of 16-gauge, metallic-coated, corrugated steel pipe,
55.0 lb/ft

$$\begin{aligned} F_{w_R} &= 6 \times 55.0 \\ &= 330.0 \text{ lb} \end{aligned}$$

The weight of the base, F_{w_B} , is the volume of the base, V_B , times the density of concrete, γ_c , which is 150 lb/ft³.

$$\begin{aligned} F_{w_B} &= V_B \times \gamma_c \\ &= 50.3 \times 150 \\ &= 7,545.0 \text{ lb} \end{aligned}$$

The weight of the saturated soil backfill, F_{w_S} , is the buoyant unit weight, γ_b \times the volume of soil backfill, V_S . The buoyant unit weight is the saturated unit weight minus the density of water. The saturated unit weight, γ_{sat} is given as 120 lb/ft³.

$$\begin{aligned} \gamma_b &= \gamma_{\text{sat}} - \gamma_w \\ &= 120 - 62.4 \\ &= 57.6 \text{ lb/ft}^3 \end{aligned}$$

The volume of the soil backfill, V_S , directly over the riser base can be calculated by subtracting the volume of the riser, V_R , from the total volume over the riser base, V_B .

$$\begin{aligned} V_B &= \frac{\pi(8)^2}{4} \times 5 \\ &= 251.3 \text{ ft}^3 \end{aligned}$$

$$\begin{aligned} V_S &= 251.3 - 141.4 \\ &= 109.9 \text{ ft}^3 \end{aligned}$$

$$\begin{aligned} F_{w_S} &= \gamma_b \times V_S \\ &= 57.6 \times 109.9 \\ &= 6,330.2 \text{ lb} \end{aligned}$$

The total resisting force due to weight:

$$\begin{aligned} F_w &= 330.0 + 7,545.0 + 6,330.2 \\ &= 14,205.2 \text{ lb} \end{aligned}$$

Example 13-5—Continued

Step 3 Sum the forces.

$$\begin{aligned}\sum F &= F_b - F_w \\ &= 11,962.1 - 14,205.2 \\ &= -2,243.1 \text{ lb}\end{aligned}$$

The negative sign indicates the resultant is acting downward, meaning the riser will not “float.” The factor of safety, FS, is the sum of the resisting forces divided by the sum of the buoyant forces.

$$\begin{aligned}FS &= \frac{F_w}{F_b} \\ &= \frac{14,205.2}{11,962.1} \\ &= 1.19\end{aligned}$$

A factor of safety of 1.5 is recommended to provide stability against overturning forces from ice or large debris or other unknown factors. Changing the thickness of the riser base is one way to add additional weight. Adding an additional 1.5 feet of thickness will increase the weight by an additional 11,308.5 pounds. It will also increase the buoyant force due to the riser by an additional 4698.9 pounds.

The new FS:

$$\begin{aligned}FS &= \frac{(14,205.2 + 11,308.9)}{(11,962.1 + 4,698.9)} \\ &= 1.53\end{aligned}$$

(iv) Sheet pile design—Sheet piling is commonly used to form high-capacity, low-head weir structures to raise water level in wetlands and bypass large storm runoff flows. It is a commonly available material, and experienced contractors are available for installation throughout the country. The two methods used for driving sheet piling are vibration and impact. Impact driving is done with drop weights or power driven hammers. Most vibratory drivers are hydraulically driven. Vibration works best in sand and gravel

material, whereas impact driving works best in fine-grained materials or foundations where large coarse-grained material, such as cobbles, may be encountered. Foundations of large cobbles, boulders, or rock are not suitable for piling. The design of sheet piling can be done with the assistance of the CWALSHT computer program. For guidance on the use of this program, contact a qualified structural engineer. Figure 13–29 provides a schematic layout of a typical sheet pile weir installation.

Figure 13–29 Schematic layout of a typical sheet pile weir installation

(a) Plan view of sheet pile weir layout

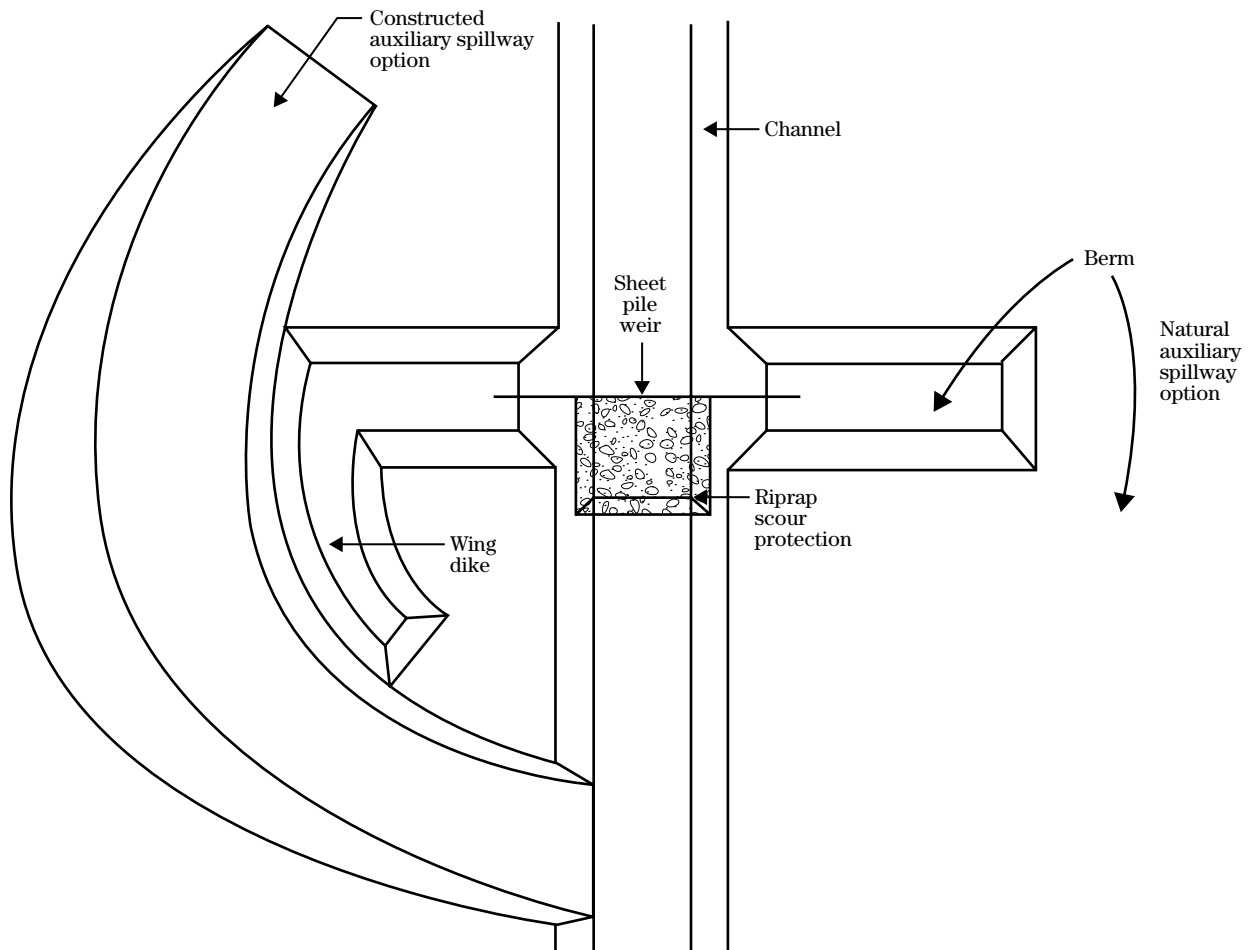
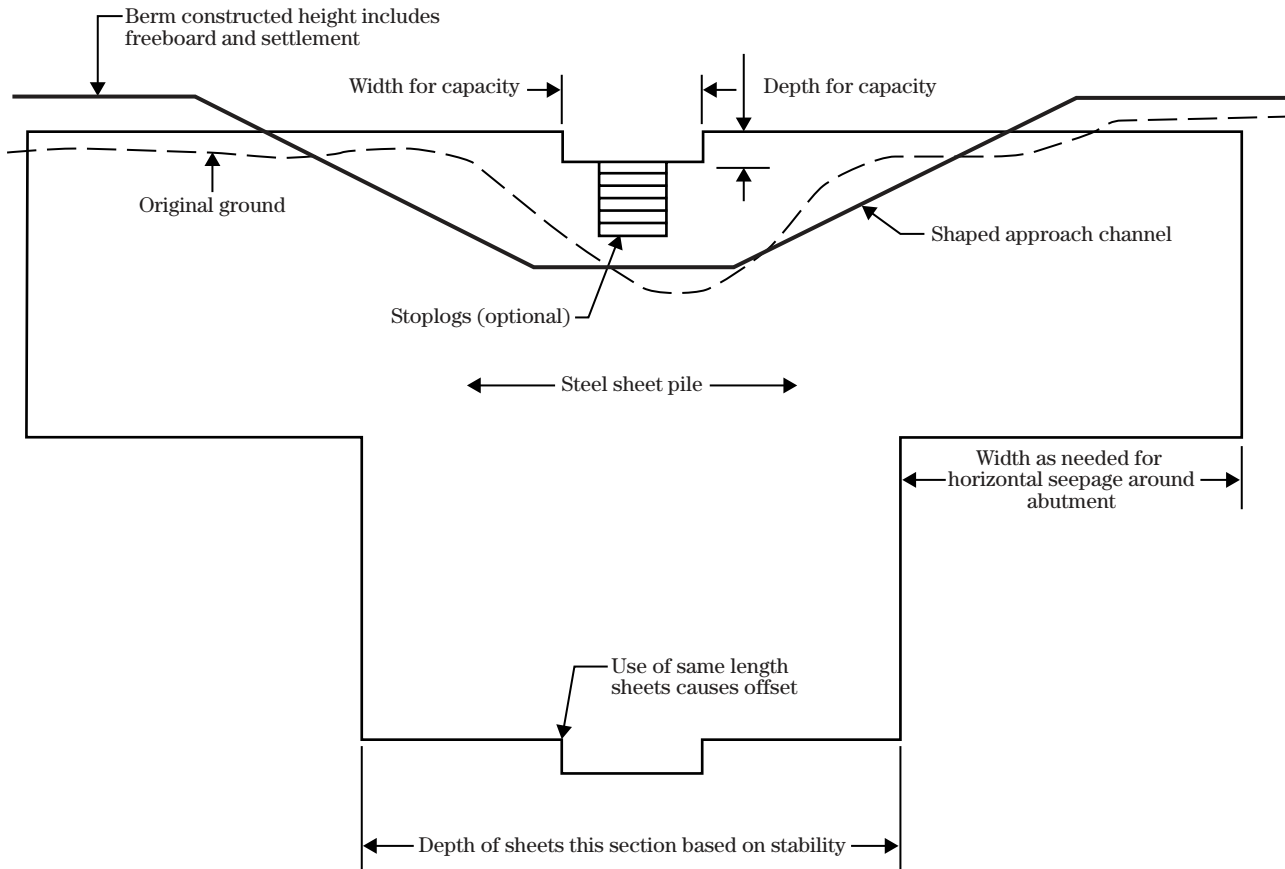
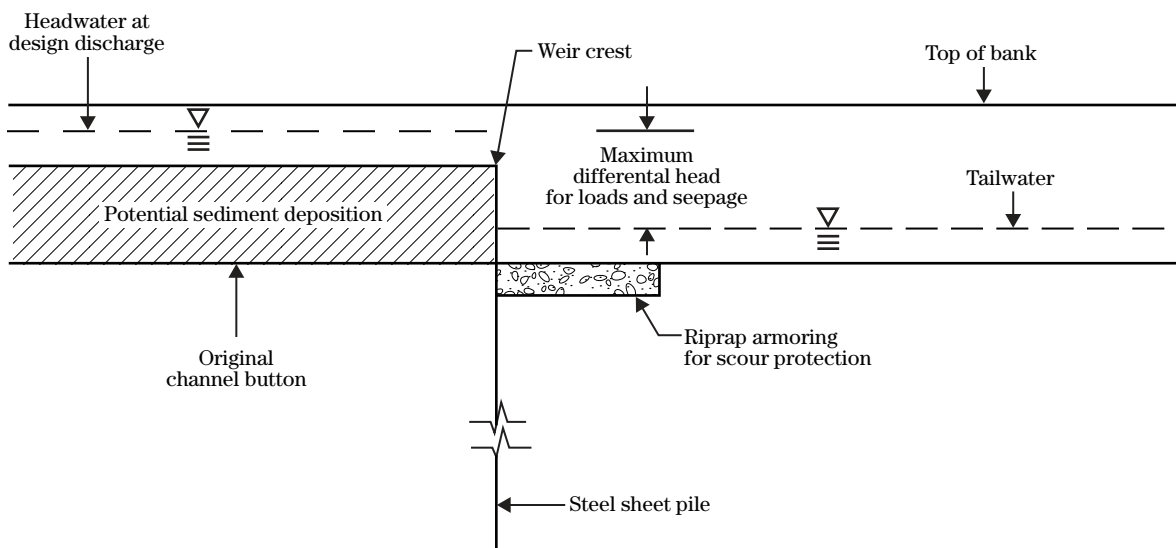

Figure 13-29 Schematic layout of a typical sheet pile weir installation—Continued

(b) Cross-sectional view of sheet pile weir layout



(c) Profile view of sheet pile weir layout



The following factors should be considered in the design of a sheet pile weir.

- Single weirs (not in series) are full-flow open grade stabilization structures meeting the purpose and criteria of FOTG Practice Standard 410. An option is to size the weir to handle the total capacity required of the principal and auxiliary spillway, which precludes the need to provide for a natural or constructed auxiliary spillway. This discharge requirement ranges from a 10-year, 24-hour storm to a 25-year storm discharge, depending on indicated rainfall and drainage area (FOTG CPS 410). The problem is that the upstream channel often does not have the capacity for this discharge (especially with backwater effects caused by the weir) and construction of the weir will force storm flows to “break out” upstream and flank the structure. The upstream channel capacity must be adequate to pass the total required storm discharge with the structure in place. The possibility of sediment deposition filling up the upstream channel must be considered.
- The maximum depth of sheet pile is based on the maximum potential loads on the structure due to water level differential across the structure and any future loading due to sediment deposition. These loads only exist across the active channel. Thus, the horizontal extent of piling driven to this depth need only extend across the channel bank and into each bank to the distance of any anticipated bank sloughing.
- It is critical that the horizontal extent of piling extend into the bank far enough to prevent horizontal seepage from causing a piping failure around the structure. When analyzing the maximum potential seepage, the potential for downstream channel grade loss must be considered. If seepage analysis shows that the phreatic water surface will exit above the lowest downstream channel elevation, drainage relief must be installed to safely outlet the flow. For guidance on seepage analysis, refer to Soil Mechanics Note 5, Flow Net Construction and Use, and NEH, Section 11, Drop Spillways. NEH, section 11 provides the “Lane’s weighted creep” ratios for various earth materials and procedures for determination of the length of flow path needed to prevent piping due to seepage. The pile depth

should also be checked for adequacy against piping. However, the maximum section depth, if adequate for stability, will usually be sufficient for piping in the vertical direction.

- Sheet pile weir drop structures can be designed as “island structures” if the water surface profile of the system provides backwater for upstream structures such that out of bank flows reenter the channel with a minimum drop over the bank. Careful placement of weir structures can provide flow reentry at natural topographic lows where there are no drop-offs or high velocity flows. Systems with “island structures” are usually a series of structures, and the downstream structure may need to be designed with a safe auxiliary spillway.

(v) Foundations

Wetlands present unique challenges to structures which are not commonly found in other projects. Wetland soils are typically low strength, cannot be effectively dewatered during construction, and may have high organic content. For these reasons, special attention must be given to the nature of structure foundations and buoyant forces acting on risers and conduits.

Refer to the criteria found in CPS 378–Pond for limits on fill height for risers and conduits.

The services of a soil mechanics engineer may be required for a detailed analysis of the settlement and consolidation potential of structure foundations. Conduits and risers of lightweight metals and plastics do not impose significant foundation loads. Concrete risers, however, should be evaluated for the potential for settlement. Also, embankments can impose loads sufficient to induce significant settlement. A detailed discussion of foundation design is beyond the scope of this document. However, the following considerations apply for most wetland structures.

Consolidated, fined-grained soil, rock, or sands and gravels near surface—Consolidated soil, rock, clean sands, and clean gravels are generally sufficient to support the loads imposed by normal wetland water control structures and embankments.

In many cases, low strength wetland soils are relatively thin layers over these materials. Consider removal of this material and replacement with compacted soil

or clean coarse-grained material up to the structure base.

Deep organic, alluvial, or unconsolidated loess soils—Embankment heights should be kept to less than 3 feet on organic soils and unconsolidated alluvium. Unconsolidated loess soils are rare in wetland landscapes. However, if encountered, they have the potential for rapid consolidation if they have not previously been saturated. Lightweight structures or steel

sheet piling should be considered for water control in these situations. Provision must be made to maintain saturation of organic soil foundations to prevent aerobic decomposition.

Various examples of water control structures are shown in figures 13–30 through 13–38.

Refer to EFH, Chapter 6, Structures, for additional information on structure types.

Figure 13–30 Cut pipe culvert



This is a high-capacity, low-head structure that can provide precise water level control, but cannot perform water level adjustments. It is typically installed in conjunction with a dike. Installation must include ballast to counteract buoyant forces.

Figure 13–31 Sheet pile vortex weir



This is a high-capacity structure with imprecise water level control, and no adjustments are possible. It is used to raise a stream water surface profile to restore wetland hydrology in a riparian wetland and must be installed in series. It is also used for stream grade stabilization. It has no buoyancy or settlement issues, but must be placed where no rock or cobbles are anticipated in foundation.

Figure 13–32 Sheet pile weir with stoplogs

This configuration has a high capacity for storm flows, good water level control, and provides for water level adjustments. It has no settlement or buoyancy issues, but must be placed where no rock or cobbles are anticipated in foundation.

Figure 13–33 Pre-cast stoplog structures

This is a medium- to low-capacity structure with good water level control and flexible water level adjustments. It is heavy enough to partially counteract buoyancy, but weight can cause settlement.

Figure 13–34 Pre-fabricated stoplog structures

This is a low-capacity structure with moderate water level control and good flexibility in water level adjustment. It has relative low weight for settlement problems, but buoyancy must be considered.

Figure 13–35 CMP riser with stoplogs

This structure has a relatively high storm capacity, moderate water level control advantages, and good flexibility for water level adjustments. There are no buoyancy or settlement issues in this configuration.

Figure 13–36 Beaver protection

This structure has a relatively high capacity for storm flows, moderate water level control, and excellent water level adjustment features. It requires high management for water level control. It also has good beaver control features.

Figure 13–37 Riser with canopy barrel inlet

This is a relatively high-capacity structure that efficiently utilizes available head to force full pipe flow. It has good water level control with good flexibility for water level adjustment. Its concrete base counteracts buoyancy and spreads weight to mitigate settlement.

Figure 13–38 Plug riser

This is a moderately high-capacity structure with good water level control and moderate flexibility for water level management.

(3) Auxiliary spillways

Where there is a contributing drainage area to the impoundment, an emergency spillway is required if the runoff volume from the design storm event cannot be temporarily stored and released through a mechanical water control structure in the required drawdown time. The capacity should be sufficient to carry the maximum inflow expected for the design storm or the peak discharge resulting from reservoir routing through the principal and auxiliary spillway system. For drainage areas less than 2,000 acres, the WinPond program can be used for routing. For drainage areas between 2,000 and 20,000 acres, use the SITES computer program.

In many cases, a natural, vegetated topographic low area can be utilized as an auxiliary spillway.

Reservoir routing of wetland structures is unique in the fact that auxiliary spillway outlet channels are usually flat and do not develop critical depth during discharge. The development of critical depth is required for traditional reservoir routing programs to generate the stage-discharge table. For this reason, a stage-discharge relationship must be developed and input into the WinPond or SITES program as user-defined auxiliary spillway discharge data. This may be accomplished simply using Manning's equation for a series of flows. The WinXSPro computer program is a channel cross section analyzer that uses surveyed cross sections, Manning's n value and channel slope to produce a stage-discharge table. A more detailed analysis can be done by using the HEC-RAS water surface profile program. Inputting a series of flows ranging from near zero to the peak discharge from the design storm will provide sufficient stage-discharge information for use as user-defined input. The use of HEC-RAS has other advantages. It can easily deal with nonuniform natural spillways by inputting cross sections of the ground surface. It also provides an analysis of tractive stress throughout the flow channel. If using HEC-RAS to model a natural spillway, space channel cross sections closely near the natural crest elevation. Examine the resulting water surface elevations at each flow through the stations near the crest. The highest profile elevation will tend to move upstream with increases in flow. It is not necessary to use stage-discharge information from the same spillway station for input into a routing program. Use the highest water surface found within all stations near the crest.

When routing is not utilized, a conservative approach is to design the auxiliary spillway to carry the peak discharge from the design storm. Use of the procedures in EFH, Chapter 7, Grassed Waterways, is appropriate. Careful consideration should be given to dealing with prolonged baseflow conditions. The mechanical water control structure should be sized to handle these baseflows unless erosion resistant materials are used in the auxiliary spillway.

When a natural overflow area is not available, a section of the embankment may be utilized as an emergency spillway. When this is done, the spillway fill section should be constructed of mineral soil, using compaction methods that will produce fill densities at least 95 percent of maximum Proctor density. The spillway geometry should meet the minimum criteria found in EFH, Chapter 11, Ponds and Reservoirs, including freeboard requirements. In addition, careful consideration should be given to measures that reduce the tractive stress on the exit channel by flattening the slope. The allowable tractive stress can be increased by the use of armoring material. An example of armoring is shown in figure 13-39.

Figure 13-39 Armoring auxiliary spillway with concrete and riprap



An auxiliary spillway is not required where the impoundment is entirely surrounded by a dike and has no contributing surface runoff. These are referred to as “ring” levee systems. The dominant water source is precipitation and can be used in areas of the country where the evapotranspiration during the wetland hydroperiod is significantly less than the 50 percent chance rainfall. These are typically installed in Mineral Flat HGM class wetlands. They should be avoided in Riverine HGM class wetlands where there is an active flood plain subject to flooding during a 25-year or more frequent discharge event.

The following recommendations apply to all auxiliary spillways for wetland structures that consist of vegetated earth, where NHCP Practice Standards 378—Pond or 410—Grade Stabilization Structure does not apply:

Locate spillway in natural, undisturbed soils if possible. Choose an area at the end of the embankment where the natural terrain approaches the fill level. If necessary, cut the depth of spillway in undisturbed ground. The side slopes should be 3H:1V or flatter. The alignment of the outlet section should be straight throughout its length, if possible.

The control section should be as flat and uniform as possible across its entire width and length to reduce variation in depth of flow and potential of erosion. A minimum length of level section upstream from the control section of 25 feet is needed.

For sites with water control structures, the emergency spillway crest should be set at an elevation above normal water level dictated by the amount of temporary storage required for the intended function (recommended minimum of 0.5 ft).

The design bottom width of an emergency spillway is determined from the required discharge capacity from the design storm. The minimum design should be a 10-year frequency, 24-hour duration storm. A larger storm may be desired in many situations.

(4) Aquatic organism passage structures

Creating or maintaining passage of aquatic organisms through a water control structure is often critical feature of wetland function (fig. 13–40). Detailed information is available for passage of salmonids during various stages of their life cycle. For many other species,

little is known about their passage abilities and needs. In some cases, the wetland function requires the construction of barriers to aquatic organisms to prevent undesirable species from damaging the wetland, or other wetland species. The remainder of this discussion will be concerned with fish. Design of fish passage structures requires data on four parameters.

(i) Life cycle stage or stages of the species to be passed—Fish may need to move upstream during spawning in the adult stage or into a wetland for rearing during their juvenile stage. Their swimming and jumping abilities are vastly different at these different stages.

(ii) Passage structure hydraulics—Each structure alternative will have its own lengths, height of drop, depth of flow, and velocities. The parameters for fish passage are flow depth, flow velocity, length of passage, and height of drop at points where flow transitions from subcritical to supercritical.

(iii) Hydrology during passage period—The minimum and maximum flow rate through the structure during the anticipated time of passage is needed. This is usually defined as flow duration. For example, many states’ permitting requirements require the ability to pass fish during the 7-day low flow at the critical fish passage period.

Figure 13–40 Fish passage between a stream and a wetland



(iv) Swimming abilities of fish—Fish swimming abilities are quantified with five parameters. These are sustained swimming speed, prolonged swimming speed, burst swimming speed, height of jump, and required water column depth. These parameters vary with fish species, life stage, and fish size, and condition. They provide the hydraulic criteria for design of structures.

The Washington Department of Fish and Wildlife (WDFW) has detailed information available on design of fish passage structures at <http://198.238.33.67/hab/engineer/habeng.htm>.

Determination of the flow duration information requires access to daily mean flow information. Stream gage data for the USGS is available at <http://waterdata.usgs.gov/nwis/sw>.

Manipulation of this data to provide the required flow duration information may require the services of a qualified hydraulic engineer.

(5) Removal of drainage measures

(i) Design of subsurface drainage blocks—Surface and subsurface drains must be blocked or controlled when necessary to restore, enhance, or create wetlands. Individual subsurface drain lines must be broken and all surface inlets removed. The broken subsurface drain must be blocked or fitted with a water control structure.

The length of the subsurface drain broken and removed should be sufficient to avoid any drainage influence from the old drain. This length will vary depending upon site conditions. The minimum length of drain removed should range from 50 feet in heavy clay soils to 150 feet in sandy or organic soils.

When a dike is to be a component of the wetland, remove the subsurface drain from the centerline of the dike to the minimum length downstream from the centerline and from the centerline of the dike to the upstream toe. None of the old drain should be left under the dike.

If a water control structure is to be installed in the drain line, locate the subsurface drain break in the basin area, and locate the control structure at the edge of the basin. The outlet conduit for the control structure should be watertight for the minimum lengths and

should have adequate crush strength to support the load of the dike, if a dike is to be installed. The ends of the broken subsurface drain lines must be capped or controlled to prevent soil from entering the remaining subsurface drain. The following methods may be used:

- Capping the ends with an external cap that is securely cemented or grouted.
- Plugging the subsurface drain at each end with an impervious material, such as cement, that will be held securely in the subsurface drain. When subsurface drain lines also function as outlets from other drained areas where drainage is still desired, appropriate measures must be incorporated to keep the upstream drainage systems functional. These measures include installing nonperforated conduit through the wetland basin; rerouting drainage lines around the basin at a distance where the drainage effect on the basin is negligible; or, where topography permits, setting a water control structure at a level that does not affect upstream drainage.

Where subsurface drains are blocked or removed, consideration must be given to the effect of the action on remaining upstream and downstream drainage systems.

Plans to install a section of impervious conduit through the wetland basin should follow these guidelines:

- Extend nonperforated conduit to a minimum of 50 feet upstream and downstream from the designed basin edge in clay soils and 150 feet beyond the basin edge in both directions in sandy or organic soils.
- Install an antiseep collar around the nonperforated conduit approximately 2 to 4 feet from the connection to existing subsurface drain at both upstream and downstream ends of the conduit. The antiseep collar should have a minimum projection of 18 inches beyond the conduit perimeter.

Under no conditions should a conduit be installed that will have less capacity than the one it is replacing.

(ii) Design of surface drainage blocks—Restoration of wetland hydrology on sites drained by surface ditches can often be accomplished by simply filling the ditch. The original excavation is often still available adjacent to the ditch. In most cases, filling the entire ditch is cost prohibitive. It is usually appropriate to fill

in one or more short sections to interrupt the drainage. There are several things to consider when designing this work. If a contributing drainage area will produce a significant storm discharge over the ditch fill, it can produce a grade stabilization hazard. Diverting runoff away from the fill site can be accomplished, but care must be taken not to move the grade stabilization hazard further downstream. Another option is to treat the site as a grade stabilization structure, and use the appropriate criteria. In general, these structures should be installed in series, with a differential water level difference of 1 foot or less from upstream to downstream.

The length of fill required is a function of the height of water stored behind the fill, and the material used. All vegetation should be stripped from the foundation, and the fill should be compacted as much as possible. In lieu of an analysis, use the following general guidelines found in table 13–5 for differential water storage heights **less than 3 feet**.

For water storage heights over 3 feet, consider lengthening the block proportionally or performing a seepage analysis to determine the appropriate length.

Figure 13–41 shows schematic layout details, cross sections, and profiles of ditch plug configurations.

An alternative method is to install a series of rock check dams. These structures are constructed of rock riprap, gravel covered with rock riprap, or compacted earth covered with rock riprap. The differential water level recommendations stated above for earthen ditch fills apply. Where a high baseflow exists, they can safely transmit water through the voids in the rock or gravel and still maintain the required upstream water surface. Often, sediment deposition fills the rock voids over time, greatly reducing the flow through the rock. The surface rock must be designed to safely handle the baseflow and any anticipated storm discharge

without displacing the rock. For earth fills covered with rock, the soil-rock interface must be protected from erosion by a geotextile fabric capable of handling the maximum anticipated tractive stress.

Figure 13–42 shows schematic details of a rock check dam installations.

Surface drainage blocks may also be constructed of steel sheet pile when soil is unavailable or the foundation is unsuitable for placing fill.

(iii) Design of basin drainage—A wetland function may require that a basin be drained for management purposes. For example, if the wetland function is primarily food production, such as rice, it may be necessary to drain both surface and subsurface water from the basin for harvesting. In wetland restorations, consider designing the structure to mimic the slow drawdown associated with natural outflows to maximize wetland function. An example of this is using slow drawdown to continuously expose mud flats for wading and shore birds. Another example of a condition that could require basin drainage would be invasion of undesirable species. Eradication may require drainage of the basin.

A water control structure should be designed to provide the depth and capacity necessary for drainage, as well as other flow (storm or seepage). Refer to table 13–6.

The needed structure capacity is based on the volume of water to remove in the given time frame. Reservoir routing programs, such as SITES, have a drawdown routine which can route the drawdown for structure sizing.

A simple analysis can be done using spreadsheet methods by computing the drawdown time in elevation increments.

Example 13–6 shows a spreadsheet analysis for a stoplog weir operation. The stage-storage values are input, as well as trial weir lengths and weir coefficients. The stoplog operation assumes that each 6-inch board will be pulled when the head on the previous board reaches 0.1 foot.

Management options can be changed by changing the values in columns 2, 3, and 4. The resulting drawdown

Table 13–5 Length of drain blocks by USCS soil class

USCS soil class	Minimum length (ft)
SM, SP, GW, GP, OL	150
ML, SC, GC	100
CL, CH, MH	50

Figure 13-41 Schematics of ditch plug layout

(a) Plan view

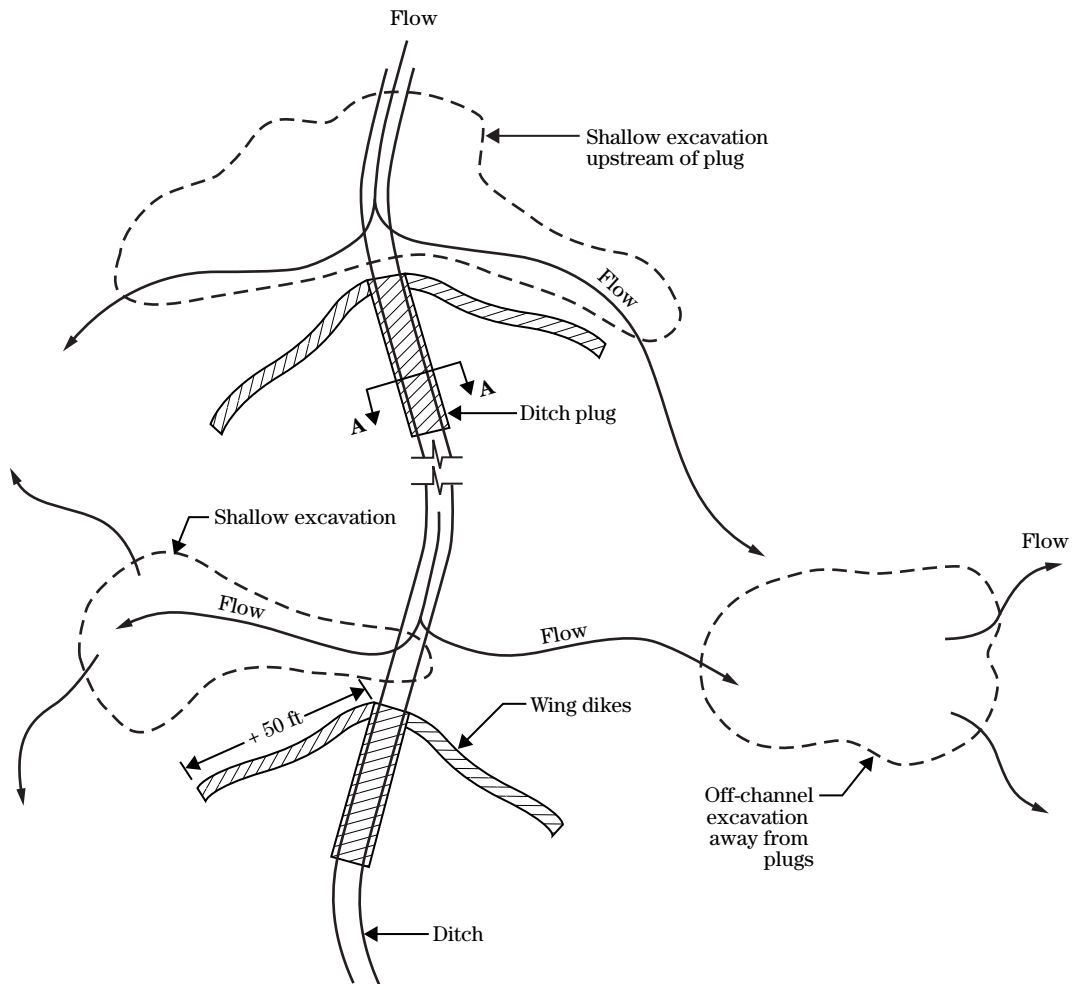
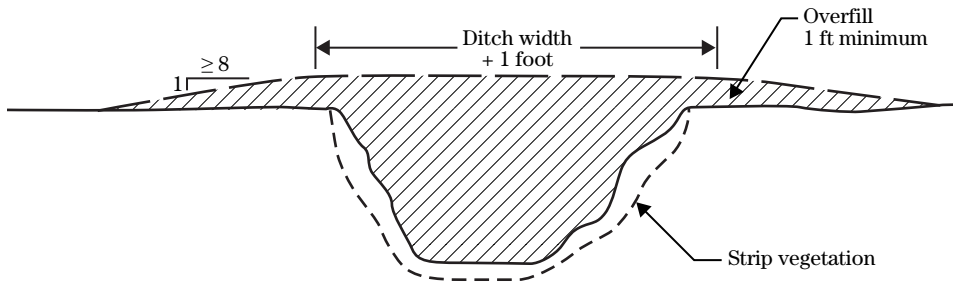

Figure 13-41 Schematics of ditch plug layout—Continued

(b) Cross section



(c) Profile

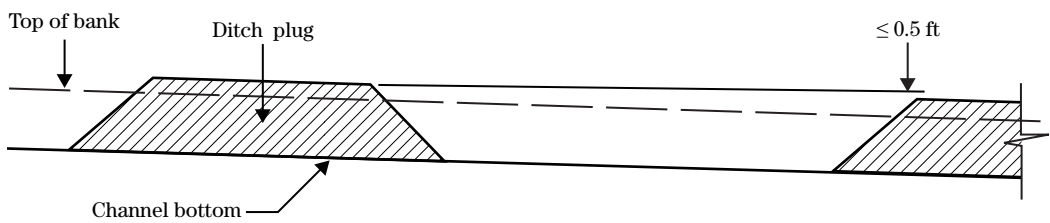

Figure 13-42 Schematics of rock check dam

(a) Cross section

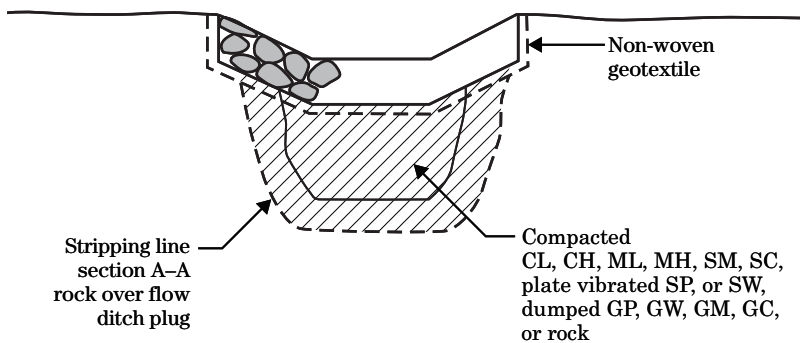
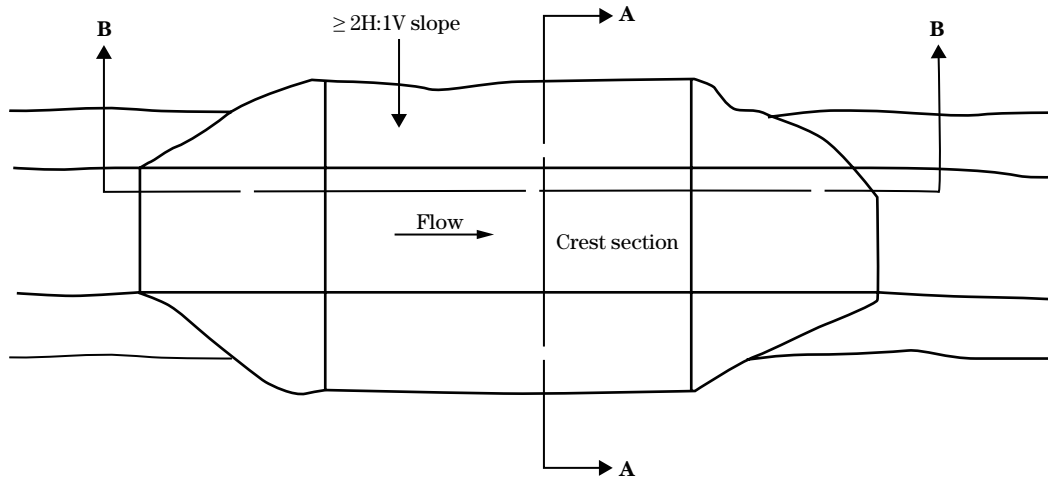

Figure 13-42 Schematics of rock check dam—Continued

(b) Plan view



(c) Profile

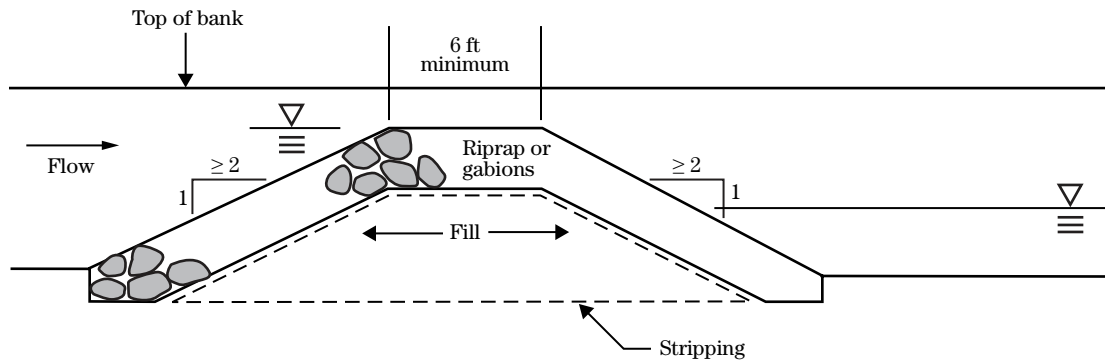

Table 13-6 Recommended removal rates for basin drainage

	Management function	Minimum removal rate (average) inches per day
Surface water	Food production	1.0-1.5
	Wetland plants	0.5
Subsurface water		0.1-0.4

Example 13-6**Drawdown Analysis -**

Weir Crest Length - 3
Weir Coefficient - 3.1

Col. 1	Col. 2	Col. 3	Col. 4	Col. 5	Col. 6	Col. 7	Col. 8
Water El.	Pull Weirs This Water Elev.	Stoplog Crest El.	Weir Head (1-2)	Storage Ac-Ft	Flow cfs	Time Hrs.	Rate In./day
100.0				63.0			
99.9			0.5	61.8	3.29	4.7	0.42
99.8			0.4	60.5	2.35	6.4	0.31
99.7			0.3	59.3	1.53	9.7	0.21
99.6	99.6		0.2	58.1	0.83	17.3	0.12
99.5		99.5	0.6	56.9	4.32	3.3	0.61
99.4			0.5	55.8	3.29	4.2	0.48
99.3			0.4	54.7	2.35	5.7	0.35
99.2			0.3	53.6	1.53	8.5	0.23
99.1	99.1		0.2	52.6	0.83	15.3	0.13
99.0		99	0.6	51.5	4.32	2.9	0.70
98.9			0.5	50.5	3.29	3.7	0.54
98.8			0.4	49.6	2.35	5.0	0.40
98.7			0.3	48.6	1.53	7.5	0.27
98.6	98.6		0.2	47.7	0.83	13.5	0.15
98.5		98.5	0.6	46.8	4.32	2.5	0.79
98.4			0.5	45.9	3.29	3.3	0.61
98.3			0.4	45.0	2.35	4.4	0.45
98.2			0.3	44.2	1.53	6.7	0.30
98.1	98.1		0.2	43.3	0.83	12.0	0.17
98.0		98	0.6	42.5	4.32	2.3	0.89
97.9			0.5	41.8	3.29	2.9	0.69
97.8			0.4	41.0	2.35	4.0	0.51
97.7			0.3	40.2	1.53	5.9	0.34
97.6	97.6		0.2	39.5	0.83	10.7	0.19
97.5		97.5	0.6	38.8	4.32	2.0	1.00
97.4			0.5	38.1	3.29	2.6	0.78
97.3			0.4	37.4	2.35	3.5	0.57
97.2			0.3	36.7	1.53	5.3	0.38
97.1	97.1		0.2	36.1	0.83	9.5	0.21
97.0		97	0.6	35.4	4.32	1.8	1.12
96.9			0.5	34.8	3.29	2.3	0.87
96.8			0.4	34.2	2.35	3.1	0.64
96.7			0.3	33.6	1.53	4.7	0.42
96.6	96.6		0.2	33.0	0.83	8.5	0.24
96.5		96.5	0.6	32.5	4.32	1.6	1.25
96.4			0.5	31.9	3.29	2.1	0.98
96.3			0.4	31.4	2.35	2.8	0.71
96.2			0.3	30.8	1.53	4.2	0.47
96.1	96.1		0.2	30.3	0.83	7.6	0.26
96.0		96		29.9			

times can be changed by changing the values in these columns for different stoplog widths and operational parameters.

(6) Ancillary structures

An array of installed practices or structures should be considered to serve the functions that are being planned and designed. Care must be taken to avoid or minimize adverse impacts upon other functions that may be planned. Observation platforms, for example, can be located near defined loafing habitat or feeding areas rather than nesting or brood rearing habitat where human disturbance should be kept to a minimum. The potential combinations are too numerous to address in this chapter, however, a few structures are cited here as examples. Design specifics for these and other ancillary structures can be found in publications listed in the references to this chapter, the FOTG, or by contacting the responsible discipline specialist.

Temporary or permanent fencing will often be necessary to control use of the completed wetland or allow vegetation to become established.

Upland islands can be created to provide nesting, roosting, and loafing habitat for both wetland wildlife and upland species that might not occur on the site otherwise. Excessive height and steepness should be avoided to prevent limited use and difficulty in vegetative establishment. Protection from wave action may require a berm 8 to 10 feet wide located at the designed water level or slope armoring, if a high degree of protection is required.

Landforms and/or vegetation can be constructed or installed to influence the circulation of people coming to a wetland for recreational or conservation education purposes. These, in combination with elevated trails, boardwalks, and elevated observation platforms, will contribute to overall enjoyment of wetland environments.

If sport hunting or fishing is planned, associated structures such as access roads, restrooms, parking areas, blinds, earthen piers, and boat access points may be needed.

(7) Microtopography restoration

Microtopography is defined as shallow depressions with a maximum depth of 6 inches. These shallow depressions fill and dry rapidly in response to gains and

losses of water to the wetland. This dynamic response provides valuable habitat functions and should be strongly considered in most restoration plans. The original, natural features are usually formed by the action of flowing water, wind, windthrow of trees, differential consolidation of wetland soils, or a number of other factors.

It is difficult to detail microtopographic features on engineering drawings. A good approach is to provide a schematic template for a microtopographic detail and require an average density and spacing per acre of restoration. Random variations in shape, depth, and spacing are preferred. In addition, construction specifications can be used to convey the design intent to a construction contractor. Line and grade design and checkout is seldom necessary and will result in unneeded time in construction quality assurance and construction cost. In addition, payment for microtopography work on a unit volume basis is problematic. Payment for this work by hour of equipment operating time or by acre of restored area has been used successfully.

(8) Hydraulic conductivity reduction

Loss of water through seepage is a significant factor of the water budget in certain depressional wetland systems or in riverine systems where a portion of the hydroperiod requires retention of floodwater in remnant flood plain features. These are cases where water is held in a perched situation and moves downward to a ground water table separated from this perched water. It is critical that the hydrodynamics of the system be determined before design. If the wetland is dependent upon ground water inflows or if an important function of the wetland is to supply water to a local ground water system through recharge, a decrease in hydraulic conductivity will be detrimental. The dominant water sources of depressional wetlands with perched water tables are surface runoff and/or direct precipitation. In natural conditions, they typically have a surface layer of soil with a high organic matter content, which provides valuable nutrients for vegetation and microinvertebrates. This layer usually lies on top of a layer of low permeability soil which forms a Bt horizon. The soil layer below this horizon usually has a higher conductivity. Restoration plans that require excavation may remove all or a portion of both of these soil horizons. Removal of the surface layer, with its high organic content may be detrimental to the wetland habitat functions. Removal of the subsurface Bt horizon can have serious negative effects on the water budget. If excava-

tion below this Bt layer is necessary, the substrate may need modification to lower its hydraulic conductivity.

In these cases, the analysis of the soil, available treatment methods, and construction techniques are in keeping with guidance available in appendix 10D of the Agricultural Waste Management Field Handbook.

(d) Vegetation design

In vegetation design, care should be taken to include plant species that match the wetland objectives, anticipated water levels, and that will perpetuate themselves in the wetland landscape. One of the first decisions will be whether the site can naturally revegetate or will need to be partially or completely revegetated by planting. Tables 13–7 and 13–8 are decision keys that will aid in that decision. Once the method of revegetation is decided, figure 13–43 will aid in determining the steps necessary to get the site vegetated according to the design. Vegetation used on dikes should be compatible with the integrity of the dike and function(s) of the wetland. Plant materials should come from local ecotypes and genetic stock similar to that within the vicinity of the wetland. Design should allow for diversity and a variety of habitat features to meet functional objectives. Local wetland plant communities should be inventoried to determine which species are adapted for the area.

Presidential Executive Order (EO) 13112, Invasive Species, stresses the use of native species, as does the NRCS Invasive Species Policy (GM 190–414). It is important to note that EO 13122 defines nativity in relation to a regional ecosystem and not broadly such as “the United States.”

Revegetation by natural colonization can develop into communities dominated by invasive species (fig. 13–44).

(1) Factors affecting plant selection

During the design phase of a wetland, 10 critical factors should be considered regarding vegetation on the site:

- *Goals and objectives*—should have been identified and firmly established in the planning phase.
- *Water supply*—includes fluctuations, inundations, flooding levels and durations, tidal re-

gimes, pool stability, water quality, water volume, and inlet and outlet locations and types.

- *Substrate*—requires consideration of soil texture, interactions among substrate, slope, and elevation, and any other planting substrate (subsoils, acid mine tailings, salinity, alkalinity) that may be encountered.
- *Water depth*—directly related to substrate saturation and water supply and to the use of water control structures. Depth of water will affect the vegetation species used.
- *Slope*—a 6H:1V or gentler slope is recommended in most cases; this is highly wetland-specific because cases of 10H:1V to 15H:1V are common. There is a direct relationship between slope gradient, slope stability, and plant species growth and survival.
- *Length of growing season*—the growing season must be long enough for the selected plant to reach full growth potential and to produce mature seed.
- *Surrounding habitats and land uses*—the vegetation must be compatible with surrounding land uses. Vegetation selection should avoid attracting nuisance animals that may be incompatible with surrounding land uses.
- *Wind and wave energy*—applies to wetlands associated with bodies of water. May adversely affect plant establishment. Select plants that will break wave action and protect shorelines.
- *Currents and velocities*—applies only to wetlands adjacent to steep gradient streams and large rivers. May adversely affect plant establishment. Select plants that will break wave action and protect shorelines.
- *Costs*—vegetation costs will vary greatly, depending upon technical decisions related to planning and design and to the difficulty of working on the site.

(2) Natural colonization

Natural colonization is defined as the process in which plant materials grow naturally on a restored or created wetland site. Natural colonization is generally the least expensive means of vegetating a wetland site (fig. 13–45). However, it requires that the propagules of the desired plant species are present on the site or will be carried to the site by water, wildlife, or wind.

Figure 13-43 Flowchart for vegetation design decisions

Table 13-7 Key to natural regeneration vs. planting: forested wetland types

1. Hydrology and soil condition marginally altered	Go to 2
1. Hydrology and soil condition significantly altered	Go to A
2. Propagules already exist on site	Go to 3
2. Propagules do not exist on site	Go to 5
3. Desirable species occur on site	Go to 4
3. Desirable species do not occur on site	Go to 5
4. Cover of plants is adequate to meet project objectives	Go to B
4. Cover of plants is inadequate to meet project objectives	Go to 5
5. Restoration site is adjacent to a surrounding seed wall	Go to 6
5. Restoration site is not adjacent to a surrounding seed wall	Go to A
6. Seed wall contains desirable species	Go to C
6. Seed wall does not contain desirable species	Go to A

A = Natural regeneration not recommended for site

B = Natural regeneration may be recommended for the entire site

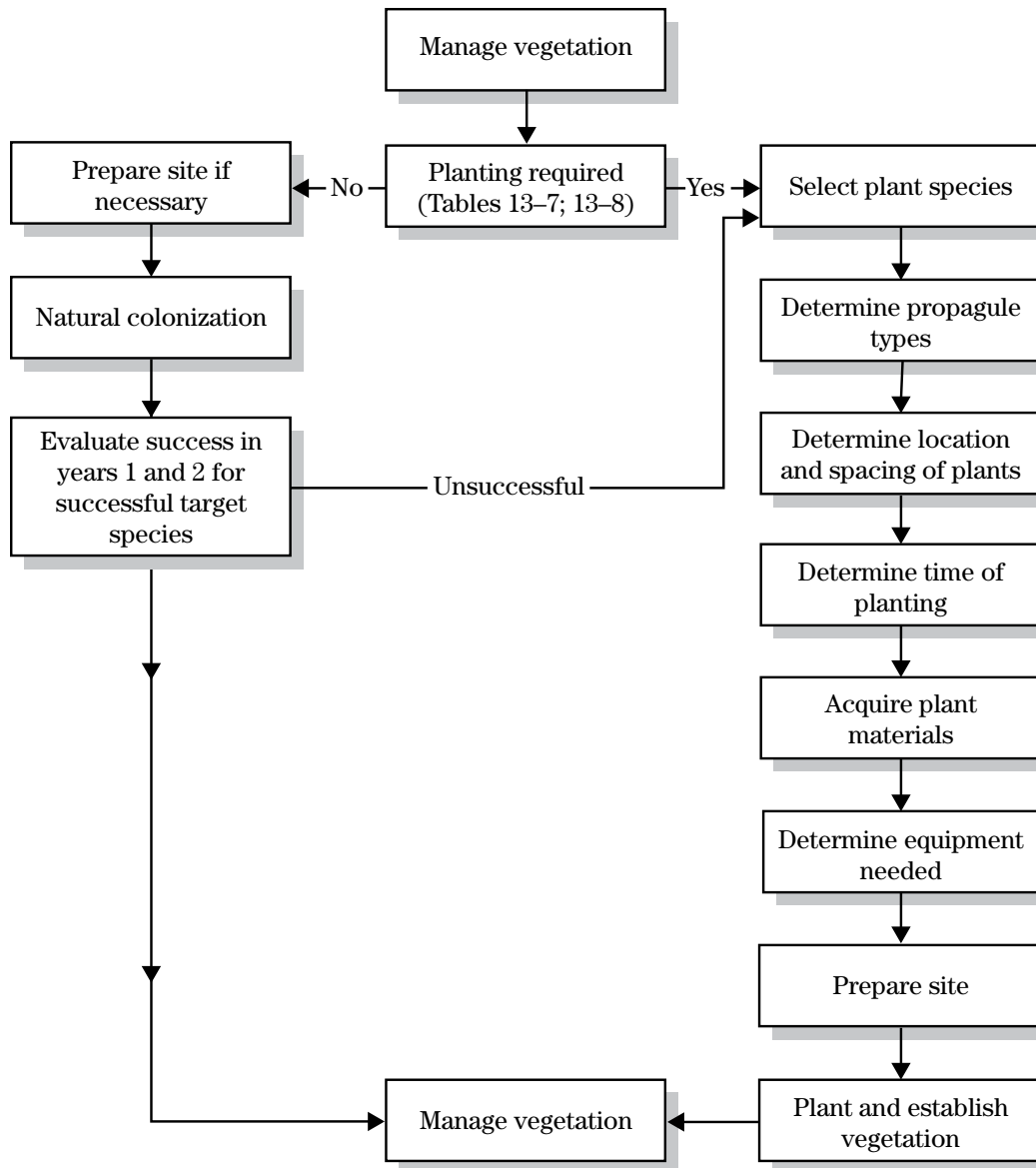
C = Natural regeneration should be no greater than 200 feet (75 m) from the surrounding seed wall

Table 13-8 Key to natural regeneration vs. planting: emergent marsh wetland types

1. Vegetation already exists on site	Go to 2
1. Vegetation does not exist on site	Go to 4
2. Desirable species occur on site	Go to 3
2. Desirable species do not occur on site	Go to 4
3. Species diversity and cover is adequate to meet project objectives	Go to A
3. Species diversity and cover is inadequate to meet project objectives	Go to 4
4. Site downstream, adjacent to, or near existing wetland	Go to 5
4. Site not downstream, adjacent to, or near existing wetland	Go to 6
5. Existing wetland contains desirable species	Go to C
5. Existing wetland does not contains desirable species	Go to 6
6. Wetland effectively drained for less than 20 years	Go to 7
6. Wetland effectively drained for more than 20 years	Go to B
7. Seed bank contains desirable species	Go to 8
7. Seed bank does not contains desirable species	Go to B
8. Density of seeds is adequate to meet project objectives	Go to A
8. Density of seeds is inadequate to meet project objectives	Go to B

A = Natural regeneration may be recommended for the site

B = Natural regeneration not recommended for the site

C = Limit natural regeneration to areas within 1/2 mile of emergent wetlands

Figure 13–44 Restoration dominated by reed canarygrass (*Phalaris arundinacea*), Washington State

Upstream or adjacent plant sources should have been examined during planning to determine the best species to encourage.

As a general rule, sites left to naturally revegetate will colonize with many individuals of only a few different early successional species. If later successional species (oaks or perennials) are part of the planting design, they may not be available from onsite propagule sources.

If extending contracts over multiple years is an option and the designer is unsure of the site's ability to vegetate naturally, the site may be left to its own resources for a period of 12 months to determine if natural revegetation will be successful. If by that time it has not vegetated naturally with the targeted species, planting should be considered. However, minimally revegetated sites are exceedingly likely to become infested with noxious and invasive species.

(3) Planting

Planting is defined as total or partial revegetation of a site through the use of seed and/or other propagules (seedlings, bulbs, corms, and tubers). The goal should be to establish a vegetatively diverse ecosystem of native species on the wetland site that is reflective of natural ecosystems in the region with the same hydrology and hydroperiod. It may be necessary to visit several natural reference sites to develop a species list and document other ecological parameters. Monostands of wetland plants do not generally address most wetland functions. Such stands may be useful in certain cases such as where only one species will survive, where a particular plant species is needed to maximize endan-

Figure 13–45 Natural regeneration on an emergent wetland, California

gered species habitat, or where monostands are used to take up contaminants for water quality improvements. The later example should be done with extreme caution to avoid concentrations of contaminants to harmful levels for wildlife.

Soil bioengineering (EFH, chs. 16 and 18) offers additional restoration and erosion control technology that encompasses the use of live cuttings or plants. Quickly established, vegetative roots bind unstable soils into a coherent mass, while the top growth of established plants serves other benefits. It is common to find complex planting plans developed for wetlands similar in concept to those developed for parks and other recreational sites. Good planting plans provide for diversity, allow multiple function uses, emphasize natural settings, and use native wetland vegetation derived from local sources.

(i) Wooded wetlands—In most wetland situations, encouragement of natural colonization of diverse vegetation or the planting of a group of species is desirable. Designs should include compatible species that tolerate the site's hydrology, elevation, water depth, and soil conditions, and that address the wetland project's goals and objectives (fig. 13–46). The planner must address horizontal and vertical structure, which includes species diversity and richness, canopy species, and understory vegetation.

Examples: For a flood plain forest restoration in Kentucky, a typical design could call for equal numbers of pin oak, *Quercus palustris*; American elm, *Ulmus americana*; American sycamore, *Platanus occidentalis*; black gum, *Nyssa sylvatica*; baldcypress,

Figure 13–46 Plant species must tolerate site conditions

Taxodium distichum; and sweet gum, *Liquidambar styraciflua*, on 10-foot centers (435 tree seedlings/acre, 72 trees of each species/acre). Trees should not be planted in straight monostand rows; instead, species should be interspersed and randomly planted to encourage maximum site diversity. This reforestation mixture is designed for variable slope areas. In other bottomland fields of uniform elevation subject to flooding, species selection should be based on the upper level of flooding. Species should have similar tolerances to flooding, require similar soil conditions, and grow at similar rates. Generally, more wet tolerant species can be planted on drier sites, but not vice versa. Refer to table 13–9 for example relative to lower Mississippi Delta.

In table 13–9, long-duration flooding or soil saturation lasts for several months at a time. Short duration occurs for a few days to a few weeks at a time. For Pacific Northwest riparian woodland, the use of black cottonwood, *Populus trichocarpa*; western sycamore,

Platanus californica; Pacific willow, *Salix lasiandra*; Pacific alder, *Alnus pacifica*; and common chokecherry, *Prunus virginiana*, may be a recommended species mixture. With trees planted on 10-foot centers and shrubs planted on 5- to 8-foot centers, cluster planting will provide habitat at several levels (canopy, understory, shrub layer, and ground) and dense cover for nesting.

(ii) Herbaceous wetlands—Regionally specific seed mixtures are commonly used to seed wet meadows, wet prairies, and fresh marsh fringes. While standard seed mixtures are given in several published planting guides, seed mixtures should generally be tailored to the wetland's targeted functions (fig. 13–47). Pay careful attention to the germination requirements for wetland seed. Many species require cold treatments and stratification before germination. Planting these species in the spring will result in vegetative failure.

Figure 13–47 Species typical of herbaceous wetlands**Table 13–9** Flood tolerances of several species in the lower Mississippi Delta

Long duration flooding Weeks to months)		Short duration flooding (days to weeks)		
January–June	January–May	January–June	January–May	January–May
Cypress	Green ash	Sweetgum	Sawtooth oak	Shumard oak
Overcup Oak	Nuttall oak	Water oak	Sycamore	Cherrybark oak
Water hickory	Persimmon	Willow oak	Cottonwood	Swamp white oak

Examples: If waterfowl habitat is a targeted function in the Southeast and natural colonization is unfeasible, seed mixtures of softstem bulrush, (*Scirpus validus*), and American threesquare, (*Scirpus americana*); seeds of sedge, (*Carex* spp), flat sedges (*Cyperus* spp.), and spike rush (*Eleocharis* spp.; and root stocks of hardstem bulrush, *Scirpus acutus*, could be included in the planting design. For root stock, planting should be on 1- to 3-foot centers, and the seed mixture should be broadcast over the vegetative plantings.

(4) Species selection and propagule types

Certain plant species will be better suited to achieving a successful wetland, depending upon planning objectives and the type of wetland to be restored or built. Desirable characteristics of such species include competitiveness, seed production, and dense root mats to stabilize the newly established wetland. The use of native or well-naturalized plant species should be encouraged. Ecological impacts of using exotic vegetation can cause ecological harm and may be prohibited by Executive Order 13112 and NRCS policy (GM 190–414). In general, plant species chosen should simulate closely a nearby wetland of similar type. The use of reference sites to document species composition and hydrology zonation is encouraged. For example, if an herbaceous Carolina Bay wetland is selected as the wetland type to be restored, plant species chosen should reflect Carolina Bay community composition on nearby sites at similar elevations and hydrologic conditions.

(i) Wooded wetlands—Woody plantings (trees and/or shrubs) come from five sources: seeds, cuttings, bareroot plantings, container stock, and dormant stub plantings. In addition, plant materials can be obtained from wetlands that are being altered. Seed should be labeled as to species composition and potential weed seed contaminants. Both seed and other plant materials should have been produced from regionally localized stock.

Where seed sources such as acorns are available, these should be harvested in the fall of the previous year. They can either be stored in a cool, dry place until spring planting and then broadcast immediately onto a prepared soil bed or inserted into shallow holes punched into the substrate (Tech Note ECS 190–15, 2003). Seeds of hard mast species should be planted on approximately 3- to 10-foot centers.

Where willows, cottonwoods, poplars, and sycamores are the species of choice, 12-inch or longer cuttings can be taken from dormant live trees. These can be stored in moist sand until planting, or they can be planted immediately on the new site by inserting cuttings on 3- to 10-foot centers. Planting dormant 6-foot (3- to 6-in-diameter) stems from cottonwoods and willows are also an effective way to establish woody species quickly.

To vegetate a wooded site more rapidly and ensure greater survival of the initial plantings, transplanted bareroot seedlings can be planted. These will shorten the time of establishment of a site by 5 to 10 years as compared to direct seeding. Wetland bareroot seedlings must be planted so that roots reach the water table and the seedlings will not die from drought stress before they have a chance to establish a viable root system. These seedlings should be planted on centers ranging from 3 to 10 feet. Bareroot stock does not store well and should be used as soon as it is dug from the nursery or donor wetland. Bareroot wetland stock lends itself very well to mechanical planting using modified commercial tree planters; and where the substrate is firm enough to allow the use of equipment, planting is both faster and more economical.

Container stock is the most expensive, but also the most reliable means of vegetating a wetland site in certain situations: rapid establishment or high stress areas. The soil ball remains intact around the root system, greatly reducing stress to the newly transplanted seedling. One-gallon container stock is usually easy to handle in the field and can be maintained in a nursery for an indefinite period of time until planting conditions are optimal. Tube planters and flats or similar smaller containerized seedlings can also be used. Container stock should be planted on centers that range from 3 to 10 feet.

Several other types of container stock have been developed for special purposes. So-called root pruned method (RPM) trees are useful for wildlife. Seedlings are grown in containers for 5 years where their roots are air-pruned. This stress forces the seedling to set seed within 5 years of planting—about 10 years earlier than barerooted stock, thus providing food for wildlife and as a propagule source for additional trees. Another special type of container stock is termed super tree. Super trees are useful where a larger plant is needed, such as for planting in deeper water or high

wave action situations. Super trees are 1-year-old seedlings that have been heavily fed and forced to reach a height of 3 to 4 feet or taller.

(ii) Herbaceous wetlands—Herbaceous wetlands contain grasses, forbs, sedges, bulrushes, cattails, reeds, and other perennial species that propagate by either seeds or vegetative stock such as tubers, rhizomes, or bulbs. Some herbaceous species colonize readily by natural means (cattails, reed canarygrass, bulrush) and can become aggressive. Other species have short seed viability periods or reproduce primarily by vegetative means. Some planting should be required if a species-rich community is targeted or particular assemblages of planting are needed for conservation purposes or for specific wildlife needs. If planting is required to stabilize a site rapidly or to accomplish mitigation, seeds or vegetative parts can be used to vegetate the wetland. Seeds are the least expensive to plant, as they are generally broadcast on the saturated surface of the wetland. However, seed sources can be unreliable and scarce. Vegetative propagules can be obtained by digging whole plants and cutting apart roots, rhizomes, tubers, and other plant parts for disk ing in, hand planting, or broadcasting on the new wetland site.

(5) Propagules

Plant materials are generally obtained from two sources: donor wetland sites and nursery-grown stock. Use of donor wetlands to obtain seeds or young plants will eventually affect the health and vigor of the donor stand, regardless of the care taken in spacing and location of plant removal areas. Removing plant materials from donor stands is not recommended unless commercial sources are not available. If donor stands are used, care should be taken to prevent degradation of that wetland. Local wetland permitting agencies may be able to provide the site locations of wetlands permitted for degradation. Such locations would serve as good donor sites.

Nursery-grown stock is generally the most reliable and ecologically appropriate way to obtain plant materials. Private wetland nurseries are becoming more widespread and can custom propagate stock for wetlands. All propagule types described previously can be provided commercially, but the most common types are seeds, container stock, or bareroot stock (fig. 13–48). Specifications for plant material to suit the wetland objectives and design should include design

needs such as plant age, stem height, root development, and container size. The American Nurseryman's Association provides an industry standard for plant material.

Examples: A clump of bareroot softstem bulrush, *Scirpus validus*, could be specified to be not less than 6 months old and 4 inches in clump density, with six live stems having attached living roots. A container-grown water oak, *Quercus nigra*, seedling could be specified to be not less than 2 years of age and well rooted in a 1-gallon biodegradable pot, with a stem height of not less than 3 feet. Such specifications are very important if plant materials are to be contracted for the new wetlands.

Figure 13–48 Bareroot nursery stock (USFWS)



(6) Time of planting

Time of planting is regionally specific, but is critical to the initial survival of the new wetland. Regional planting times are well known by local specialists, and they should be consulted if written guides are not available in the local NRCS office. Generally, planting is best done during dormant season while the ground is not frozen. Often, planting seed prior to freezing will allow the seed to stratify naturally. Losses from heat stress and drought will occur when bareroot stock is planted in the hot summer months. Consult the FOTG for planting times.

(7) Site preparation

Once the wetland area has been shaped and graded, the site should also be disked, harrowed, and prepared for sowing of seeds or planting root stock or seedlings. While these preparations are being made, soil amendments recommended from the soil analysis (conducted during planning) are added. For example, slow-release, all-purpose fertilizers and ground limestone should be incorporated into the soil. Depending on the planned species and water level management, it is often a good idea to release water onto a site to facilitate soil setting prior to planting, especially where slopes are critical. This can aid in the prevention of high spots and possible vegetation loss.

(8) Equipment

Seedbed preparation and planting in wetlands generally do not require specialized equipment. In most cases, standard farming equipment (tractors, disks, harrows) can be used in a wetland, depending upon the firmness of the substrate and on whether the water source is fully applied to the site at the time of planting.

Modified tree planters (fig. 13–49) can be used for bareroot wetland tree and shrub species. In wetlands where soil is saturated at the time of planting, the commercially available tracked or light foot pressure equipment is suitable for planting such sites. Where mud is soft and seeds of chosen species are used, aerial seeding may be necessary. In soft substrates where transplanting of plant materials is required, hand planting with dibbles has been found to work well. Designs and specs must include equipment requirements to be sure that the job is done correctly without damage to adjacent existing wetlands or surrounding areas.

(9) Plant installation

Planting considerations include spacing, sizing, timing of planting, and species-specific requirements. Additional considerations may include hydromulching, adsorbents, and the need for nurse or cover crops to protect the desired species until they are well established. Hydromulching is more commonly used in wetlands in the Western United States and is an aid where water shortages may occur in early stages of site establishment. Hydromulching may include in the slurry—seeds, fertilizers, chopped mulch (hay, straw), and tackifiers to hold the mulch to the substrate surface. Seeds can be coated in advance with adsorbents to give them a better chance of survival during germination. This should be a design consideration where planting is expected in summer months or in the Western United States. Refer to commercial hydromulching guides to write design specifications.

Nurse crops may be valuable in protecting the new wetland, especially on sandy soils or where climax forest is the desired wetland type. Planting a nurse crop such as a cereal grain or other regionally specific nurse crop will provide erosion control. Refer to the FOTG for planting rates.

Examples: Legumes and annual small grains are planted as nurse crops along with young bottomland hardwood seedlings. Early successional stage willows and cottonwoods are planted on streambanks, and climax flood plain species are encouraged to colonize or are planted after the willows and cottonwoods have stabilized the bank.

Figure 13–49 Modified planter for acorns



(10) Nuisance species control

In many regions, grazing by geese, nutria, muskrats, deer, and several species of ducks on establishing wetland plants may have major impacts on the new wetland. Ways to prevent degradation can be obtained from local officials of the Extension Service and fish and wildlife agencies.

(11) Noxious, invasive, and alien plants

Rapid colonization by these species (generically called invasive species) on newly restored, enhanced, or created sites can pose significant threats to project success. They may be present in the soil seed bank, dispersed to the site by wind from surrounding landscapes, be introduced by flooding, or be carried in the fur, feathers, or digestive tract of visiting wildlife. They interfere with success in multiple ways, but generally they outcompete natives, lower overall species diversity, alter the soil (salinization), consume excess amounts of water (phreatophyte), or do not provide proper food or cover for targeted wildlife. In addition, some of these species may pose threats to surrounding agricultural or urban lands. The wetland site should not be allowed to serve as a propagule source into these surrounding areas.

Invasive species are adapted to rapid spread on open sites, and their seed is often persistent in the seed bank longer than many native species. They colonize and cover a site so rapidly that native species have a difficult time establishing because of the severe competition. In some cases, invasives produce toxins or other exudates (allelopathic agents) from their roots or leaves that prevent the germination or establishment of other species.

It is of critical importance to know what invasive species are in your geographic area that may pose a threat. It is also critical that sites are assessed for potential invasive species invasions prior to construction. If a site has an infestation of invasive species prior to the restoration work, it is often appropriate to delay the work until the invasives are removed by cultivation, chemical, or biological means. By cultivation, a site's seed bank can be reduced or depleted.

As a general rule, stabilizing a site with targeted vegetation early on in the project will deter rapid dominance by invasive species through competition. Even when doing vegetation work early, some invasives may colonize; however, it is easier to treat spot introductions than it is to rework a site infested by invasives.

650.1305 Construction**(a) Roles and responsibilities**

The construction process involves several different parties, with specific roles and responsibilities. It involves the installation of a restored, created, or enhanced wetland by a construction contractor who performs the work in accordance with drawings and specifications prepared by the designer. Construction is implemented under a construction contract. The parties involved and their roles and responsibilities are listed.

(1) Contractor

The contractor physically installs the project. The contractor is responsible for determining the work and materials required; preparing a bid for the work; following the designer's drawings and specifications; and observing the health, safety, environmental, and socioeconomic requirements stated in the contract, or as required of a contractor by Federal, state, or local laws and regulations. The contractor promptly informs the construction inspector of any differing site conditions affecting the difficulty of the work or the designer's intent. The contractor performs quality control on the work and materials incorporated into the project.

(2) Designer

The designer is an engineer or an NRCS employee performing design duties under the Job Approval Authority of an NRCS engineer. The designer participates in the development of the project plan; designs the project in accordance with the plan; prepares drawings, specifications, a cost estimate based on estimated quantities; an operation and maintenance (O&M) plan for the structural measures in the design; estimates the contract performance time; and assists with construction contracting by preparing bid documents. The designer also determines the level of inspection required for the project and informs the appropriate supervisory personnel of the inspection time involved. The designer prepares and/or approves modifications to the design before they are implemented. The designer also certifies quantities for progress and final payments. The designer certifies completion of the work to the contracting officer.

(3) Owner or sponsor

The owner or sponsor is the decision maker for the project. On projects which are not Federal acquisitions under the Federal Acquisition Regulations (FAR), the owner makes payment to the contractor. The owner works closely with the planners and designer to make certain that the final plans are satisfactory. On Landowner Agreement contracts, the owner acts as the contracting officer.

(4) Construction inspector

The inspector becomes intimately familiar with the plans and specifications and fully understands the designer's intent. The inspector measures quantities, observes construction methods, performs tests, and records construction activities. The inspector promptly informs the contractor of work that does not comply with the drawings, specifications, or other requirements of the contract. The inspector performs quality assurance on the contractor's methods, materials, and construction methods to ensure that the completed work meets the requirements of the contract. Additional information on construction inspection methods and requirements can be found in NEH-19, Construction Inspection.

(5) Contracting officer

All contract actions are performed by the contracting officer (CO). The CO receives bids, awards the contract, makes changes (modifications) to the contract, and approves payments. The CO receives technical advice from the designer including payment estimates, cost and technical data for changes, and recommendations for acceptance or rejection of the work.

(b) Types of contracts**(1) Cost-share agreements (landowner agreements)**

When construction is performed under a landowner agreement, the landowner serves as the CO. The contract is between the landowner and the contractor and may be as simple as a verbal agreement. As CO, the landowner selects the contractor, makes payment, orders needed modifications, and negotiates the changed cost and time with the contractor. The landowner receives quantity measurements from the inspector for partial payments, if needed. The landowner also accepts certification of completion from the designer. Landowner agreement contracts should only be used

for relatively small, simple projects that can be completed within a short time frame. The landowner may or may not receive 100 percent reimbursement of the construction cost from NRCS, depending on the programmatic arrangements for the particular project.

(2) FAR contracts

FAR contracts are formal Federal construction contracts implemented in accordance with the FAR. Roles and responsibilities are clearly defined; performance and payment bonds are required; and various safety, health, and socioeconomic requirements are included as part of the contract. The plans and specifications must be prepared in accordance with NEH 642, Specifications for Construction Contracts. These contracts have strong protections, rights, and remedies included for all parties involved. However, the contracting time is increased, extra costs are required for bonding, and the administrative costs and time are increased. This method is typically used on large, complex projects, with a long construction time frame.

(3) Third party contracts

There are a number of methods for implementing a project in which a third party performs the construction contracting including contribution agreements and cooperative agreements. The third party contracts with a construction contractor, administers the contract, and makes payments. They accept certification of completion from the designer and receive partial or total reimbursement from NRCS for construction costs.

(4) Local contracts

Local contracts are formal construction contracts that are very similar to those implemented under the FAR. However, the procedures and documentation requirements are covered in the National Contracts, Grants, and Cooperative Agreements Manual (NCGCAM). They require a sponsoring local organization (SLO). The SLO provides a CO who performs the same duties as the CO under a FAR contract. All other roles and responsibilities remain the same. The SLO receives reimbursement from NRCS for partial and final contract payments before making payments to the contractor.

(5) Force accounts

Force account contracts are constructed by a unit of government that has its own equipment and labor. The designer estimates the hours of labor and equipment and needed materials. The cost per hour for equip-

ment and labor and per unit for materials is negotiated, and the contractor is reimbursed accordingly. The Inspector records hours and quantities, and reports the totals to the CO.

(6) Considerations for all contracts

A project may require separate construction contracts for implementation. For instance, a separate vegetative establishment contract can be initiated following a contract for earthwork and structures. A large project may need phased implementation. Different contracting methods may be used for different contract phases. A preconstruction conference attended by the designer, inspector, and contractor should be held, and all items of the contract including measurement, payment, plans, specifications, and construction schedule should be discussed. Minutes should be kept, and a copy of the minutes distributed to all attendees.

(c) Quality assurance

While the construction contractor is responsible for quality control, it is the unique responsibility of the construction inspector to perform quality assurance activities. Quality control involves the use of methods and techniques of construction which will provide a finished product that meets the contract requirements. Quality assurance, on the other hand, involves performing the tests, measurements, and observations to actually document adherence to those requirements. Activities included are compaction testing of earthfill, tests of fresh concrete, compressive strength tests of concrete test specimens, observing markings of delivered materials, surveying line and grade of slopes and conduits, measuring placement of reinforcing bars, collecting weight tickets for riprap or vegetative mulch, measuring installed quantities, measuring areas of seeding or clearing, and many other activities. It is also necessary for the inspector to maintain a close but firm working relationship with the contractor's job site superintendent so that he or she anticipates future construction activities, provides prompt interpretations of drawings and specifications, and informs the superintendent as soon as possible of work not meeting contract requirements.

Safety, health, and socioeconomic requirements are often included as part of the construction contract, particularly in FAR and local (NCGCAM) contracts. The

inspector is responsible for informing the contractor of noncompliance of these requirements, as well. It is important to note that conveying notice of noncompliance with contract compliance and documentation of this notice is all that is required of the inspector. It is the CO's responsibility to take enforcement actions.

(d) Construction of the wetland

Successful construction of the wetland project starts with plans and specifications that take into account the unique challenges presented by hydric soils and wetland hydrology. Figure 13–50 shows typical wetland construction. Structural design issues were described in section 1304(c). Construction challenges must be taken into consideration when selecting a design alternative. General information of construction and quality assurance procedures can be found in EFM, Chapter 17, Construction, and NEH–19, Construction Inspection. Selected construction issues are described.

(1) Dewatering

The designer should determine whether a design alternative will require dewatering and whether the needed dewatering is feasible. Dewatering methods include surface ditches, shallow wells, diverting surface in-

Figure 13–50 Construction in a riverine wetland project



flows, diverting streamflows, or other methods (fig. 13–51). The construction quality assurance personnel must be aware of the designer’s intent for the degree of dewatering. For instance, if the embankment design assumed compaction to 95 percent of maximum Proctor density, the borrow must be dewatered to achieve this density. The contractor’s proposed dewatering plan should be discussed during the preconstruction conference. The dewatering plan must be implemented in accordance with other Federal, state, and local laws and regulations. Special consideration should be given to water rights issues, and National Pollution Discharge Elimination System (NPDES) considerations (see next).

(2) Pollution control

Depending on the size of the project and state regulations, a NPDES permit may be required. If needed, this permit requires that a plan be developed to prevent sediment and other pollutants from entering surface water during construction. Even if a permit is not needed, measures should be taken to prevent excess pollutants from leaving the project site. Individual measures taken to prevent sediment pollution include:

- installing seeding and mulching
- installing permanent vegetative cover as areas are completed
- diverting clean runoff water away from construction areas

- trapping sediment with silt fences, bale dikes, or sediment control basins
- staging construction to minimize the area left unprotected from erosion at one time
- installing haul roads on the contour
- bypassing clean water in live streams downstream of the project
- diverting or pumping polluted stream water onto a sediment filtering area before reentering the stream
- limiting clearing to small areas at a time to minimize disturbed areas
- armoring, bridging, or installing culverts at stream crossings
- providing winter or seasonal shutdowns

Other pollution sources include fuel and lubricant storage facilities, air pollution from burning trees and rubbish, sanitary facilities, noise, and dust.

In some cases, staging construction activities in a particular order can greatly improve the pollution control effort. Providing a borrow area to divert surface runoff into is an effective means of pollution control. Completing a dike at the lower end of a project first can preclude the need for internal sediment control structures.

The contractor should be asked to develop a pollution control plan for discussion at the preconstruction conference.

Figure 13–51 Dewatering a pit to be filled as part of restoration



(3) Threatened and endangered species

In some cases, a condition of the project permit is that construction be managed to minimize impacts to threatened and endangered species. This requires constant monitoring to determine whether the permit assumptions have changed during construction and making the proper notifications, usually to the USFWS. Specific issues include the location of nesting sites, timing of fish runs, and the presence of unknown endangered flora, fauna, or habitat sites found during construction.

(4) Cultural resources

Many, if not most, cultural resource discoveries are made during construction projects. The project inspec-

tor should have received training on the recognition of cultural resources and procedures to be taken if a discovery is made. Detailed information on NRCS policy and procedures is in GM 420, Part 401, and the FOTG, Section II.

(5) Construction equipment

Careful consideration for the need and availability of special construction equipment should be a part of the design process. Wetlands usually require the use of lower ground pressure equipment (fig. 13–52). Smaller equipment, machines with wide tracks, backhoes with long “reaches,” and other features are often required. In some cases, equipment can make use of the existence of shallow rock, granular material, or firm clays and shales to operate. A careful geotechnical investigation can determine these conditions.

(6) Construction schedule

The designer should also carefully consider the time frame anticipated for construction and determine whether the project can be completed outside the wetland’s hydroperiod. In many cases, projects can be started and completed before the normal wet season. Design alternatives that have a shorter time requirement should be considered. The anticipated conditions and selected design alternative affect the construction period, cost, and inspection personnel requirements. The contractor’s construction schedule should be discussed at the preconstruction conference. The proposed schedule will have an effect on safety, pollution

control, delivery of materials, cultural resources considerations, threatened and endangered species considerations, construction inspection and quality assurance requirements, payments, and most other aspects of the project.

(7) Safety and sanitary requirements

Depending on the type of contract, NRCS personnel may or may not have specific responsibilities for enforcing safety provisions during construction. Contract work performed under FAR or NCGCAM provisions incorporate safety provisions which include the requirements of OSHA Part 1910 and 1926, as well as the NRCS Supplement to OSHA. Landowner agreements and other contracts do not incorporate safety provisions. Regardless of whether NRCS personnel have specific safety enforcement responsibilities during construction, quality assurance personnel should be aware of potential hazards during construction. The following is a partial list of considerations pertaining to wetland construction in lieu of specific contract requirements.

- Rollover protection systems including functioning seat belts should be in place on all moving equipment.
- Personnel exposed to danger from overhead construction should wear hard hats made in accordance with American National Standards Institute (ANSI) Z–98.1.
- Open trenches that pose a cave-in hazard should not be entered without proper shoring. In general, open trenches deeper than 5 feet must be shored in typical ground conditions. Conditions considered “typical” rarely exist in wetland construction. Saturated soils with moving ground water pose an extreme hazard for cave-ins. For this reason, entering vertical wall trenches of any more than minimal depth should be avoided in most wetland situations.
- Construction equipment should have properly functioning brakes, mufflers, and back-up alarms.
- Chains, cables, and straps used for lifting should be in good condition, of the proper size, and equipped with safety latches.
- Storage for fuel and other flammable material should be properly signed and marked with signs prohibiting smoking within 50 feet.

Figure 13–52 Wetland construction often requires low ground pressure equipment



- Open burning must be conducted under the conditions of any required permits. Consider clearing firebreaks and maintaining water and equipment for firefighting onsite during burns.
- Commercially available chemical toilets should be provided for sanitary facilities and maintained regularly.

(e) General considerations for structural components

(1) Dikes and levees

Foundation areas for all dikes should be cleared of trees, stumps, logs, roots, brush, boulders, or organic matter. Channel banks and sharp breaks should be sloped no steeper than 1.5H:1V. Organic soils should be removed from the foundation area, except where the dike will be constructed from organic soil or geotextiles are used to improve foundation conditions. For dikes constructed in organic soils, the top 2 feet from a borrow area should be placed at both toes of the embankment to keep the softer material toward the outside margins of the fill.

A cutoff trench, if planned, should be excavated approximately along the centerline of the dike. The trench should be backfilled with the least permeable soil available and compacted. The excavated material, if suitable, may be used elsewhere in the dike fill. Where the dike crosses old channels, the soft, unsuitable material should be removed from the base section. The bank of the old channel should be sloped no steeper than 1.5H:1V before placing the new fill.

Dikes are often constructed from spoil excavated from drainage ditches. The spoil is placed to the required height and shaped. If the spoil is wet, allow for draining and drying before shaping. Where additional stability by compacting is needed, the dike should be constructed in stages.

Generally, the borrow is taken from the waterside of the dike. Ditches are sometimes overexcavated to obtain additional fill material. At times, fill must be obtained from the landside, especially when this practice eliminates excavating through highly permeable strata on the waterside, which could result in excessive seepage through and under the dike during flood stages.

A borrow ditch on the landside may be planned as a unit of the interior drainage system and the excavated material used in the dike. Such a ditch should be far enough away from the dike to eliminate undermining. Physical features, such as roads and railroads or the lack of suitable material, may require that the borrow be transported from a distant point.

If a borrow ditch located along the waterside is not part of the interior drainage system, it should be interrupted at intervals to slow the velocity of the water moving along the toe of the fill.

Such unexcavated plugs also serve as crossovers for maintenance equipment at low water stages. They should be spaced at intervals not to exceed 1,320 feet and should be at least 25 feet wide.

(2) Conduits

Any conduit through a dike should be placed on a firm foundation. Selected backfill material should be placed in layers 6 to 8 inches thick around the conduit and each layer thoroughly hand compacted. Compaction can be a problem because of wet conditions. The conduit itself should be watertight. Antiseep collars or drainage diaphragms should be used for added control of seepage along the surface of the conduit.

(3) Pilings

Bearing piles may be required in wetland projects to support different components such as access walkways, docks, and pipes.

Wood piles shall be of sound wood, free of decay and insect attack, and of a size compatible with the intended use. Steel sheet piling is often utilized for construction of weirs and bulkheads. For guidance on installation and specifications, consult NEH, Part 642, Specifications for Construction Contracts, chapters 2 and 3.

(4) Construction equipment

Consideration should be given to types of equipment to be used for earth moving, site preparation, and seeding or planting the site. Table 13-10 lists some types of equipment used in wetland sites where flooding has not yet occurred, where soils are already saturated, or where standing water already exists.

Table 13-10 Construction equipment vs. site conditions

	Dry land	Saturated soil	Standing water
Bulldozer	X	X (sand)	
Backhoe	X	X	
Hydraulic excavator/trackhoe	X	X (sand)	X*
Tree planter	X	X	
Root grubber	X		
Disk/plow	X		
Harrow	X		
Rototiller	X		
Sub-soiler	X		
Broadcast seeder	X	X	
Drill seeder	X		
Light ground-pressure equipment		X	X*
Special wide tracks		X	X*
Rubber-tracked equipment		X	X*
Scraper (road grader)		X	
Sled		X	X*
Floating platforms			X
Hydraulic dredge			X
Bucket dredge		X	X
Dragline dredge		X	X
Dewatering trencher		X	X

*Only applicable under shallow water less than 2 feet deep

(f) Wetland soils as sources of plant materials

Wetland topsoils provide unique sources of plant materials provided propagules of the targeted vegetation occur in the profile. Other than a potential propagule source, wetland topsoils contain abundant organic material, as well as nutrients, fungi, and other beneficial microbes.

Although some plant seeds will remain viable for hundreds of years, few species have that ability. Many factors contribute to the quantity and quality of seeds in a soil profile, that is, length of time drained or not in wetland vegetation. As a general rule, weedy annual species will have seeds remaining viable much longer than later successional stage species.

If wetland topsoil is to be used, remove the top 12 inches for seeds and propagules. Additional material may be used from deeper depths if it is rich in organic material. Soil should be stockpiled in linear rows no greater than 3 feet high by 3 feet wide; otherwise, the material may compost and destroy the propagules. Do not let it dry out, and keep it covered if it will be stockpiled for long durations so that it does not become contaminated by weed or invasive species seed. Store piles in a low, undisturbed area where saturated conditions can be maintained. Line the storage area with plastic to prevent water percolation and oxidation of the sod. This will also protect the wetland seed bank within the stockpiled soil. In handling wetland topsoil, avoid compaction of undisturbed or stockpiled soils since fleshy propagules (bulbs, corms, tubers, and rhizomes) may be crushed or damaged.

When spreading topsoil determine the depth to be spread. This should be no more than 6 inches deep. The receiving sites are excavated to grade to accommodate the additional topsoil from the donor wetlands. Then the sites are allowed to grow naturally from the seed bank present in the topsoil. If the volume of topsoil is minimal, a thin layer of topsoil or some random spot placements will augment vegetation success.

(g) Vegetative establishment

(1) Plant material

If the wetland is to colonize naturally, there are no additional requirements for vegetation other than possible site preparation during implementation. If the wetland is to be planted, plant materials should be transported to the wetland site and temporarily stored there, under saturated or standing water conditions, if necessary. The easiest means of transporting and holding bareroot, cutting, or root stock plant materials just prior to planting is in plastic containers or bags that will prevent moisture loss. Seeds should remain stored in cool conditions away from the site until planting is to occur. Container stock, the bulkiest of plant materials to move to a planting site, should be placed in shade shortly before planting and kept moist at all times.

(2) Site preparation

Disking and harrowing of the site should take place just prior to planting, and after all other earth moving and shaping is completed. If earth moving is completed several months prior to the recommended planting time, do not disk and harrow until time to plant. If transplants are to be used, incorporate fertilizer and/or limestone, if needed, during disking and harrowing prior to planting. Care should be taken to prepare a substrate that will maximize root growth in the shortest period of time.

(3) Planting

Planting the wetland is generally the final task. Care must be taken to follow recommended spacing, random placement for diversity, and all other specifications set forth in the design to achieve the desired wetland objectives. In certain cases, especially in the semiarid West, once planting commences, temporary irrigation may be necessary to ensure germination, growth, and survival until root systems are well established.

650.1306 Management

Wetland management is defined as activities that assure the wetland *will perform* its intended function. This is different than maintenance, which is *considered preventative or corrective activity* necessary to ensure the proper functioning and operation of both the structural and biological components.

A wetland management plan is required for each restored, enhanced, or created wetland. The plan should be developed in conjunction with the wetland restoration plan and should reflect the overall project goals and intended functions. This section outlines the general concepts of wetland management for wildlife. This function is highlighted because:

- Management information is readily available.
- It is the reason many landowners restore, enhance or create wetlands.

Generally wetland management activities are specified in an O&M plan and should be aimed at realizing the objectives established for the wetland during planning. For wildlife, objectives may include items such as manipulating water levels for wildlife benefit, planting food plots, establishing certain vegetation types, or specifying periodic disking to stimulate moist soil plants. As with success criteria and monitoring activities, the items in the management plan should be flexible enough for wetland benefits to be achieved even if unforeseen factors limit the realization of planned wetland functions.

(a) Prairie pothole management

Prairie potholes are extremely valuable fish and wildlife habitats simply because they are diverse, dynamic, and very productive (fig. 13–53). In the prairie pothole region, these wetlands occur in a variety of freshwater habitats ranging from small, shallow, ephemeral wetlands to large, permanent, deep-water marshes. Prairie wetlands are dynamic because they are always changing due to cyclic weather patterns (natural draw-down/re-flooding cycle) and wildlife activity, and they provide a wide range of economic, biological, and hydrological values.

Successful management of prairie potholes will recognize the diversity of these wetlands and their natural drawdown/re-flooding cycles. Consequently, management plans designed for prairie potholes should maintain a variety of wetland types within a local area to allow natural drawdown/re-flooding to occur. Efforts to increase water depths of historically shallow prairie potholes should be avoided since doing so would decrease the biological diversity within an area. Likewise, efforts to concentrate water within shallow wetlands should be avoided. Waterfowl and other water-dependent wildlife need a variety of wetland habitats at various times throughout the year. Converting most wetlands to semipermanent or permanent wetlands would actually decrease the abundance and diversity of wildlife habitat.

Wild ducks are divided into two groups according to habitat requirements. Diving ducks, such as canvasback, redhead, scaup, and ring-necked duck, dive for food and usually do not feed on land. They nest in vegetation along the shore or within emergent vegetation over the water. The more common puddle ducks are represented by the mallard, shoveler, pintail, and teal. These ducks generally nest within a few hundred feet of water, but can nest in hay fields or odd areas over a half mile from water. The hen takes the brood to open water after hatching.

Potholes that are overgrown with emergent vegetation (generally cattails) have only limited waterfowl production potential. In these cases, some temporary control of emergent vegetation may be obtained through

Figure 13–53 Wetlands containing a mixture of open water and dense vegetation provide productive waterfowl habitat in a prairie pothole



the use of herbicides or late fall mowing. Where manipulation of water levels is feasible, especially in partially drained wetlands, water control structures can be installed to assist in vegetation control. Through maintenance of water depths of 3 1/2 to 4 feet, dense stands of emergent vegetation can be reduced. The most ideal waterfowl brood habitat is a wetland containing 50 percent open water and 50 percent emergent vegetation.

In most prairie potholes, dredging does not improve waterfowl and other wildlife habitat and should be avoided, especially where nesting islands and adjacent excavated deep-water habitats are established in small ephemeral wetlands.

(b) Seasonally flooded impoundments for wildlife

These areas are typically flooded in the winter and drained or dried during the summer to improve waterfowl habitat (fig. 13–54). The vegetation can be categorized as either desirable for food and cover or undesirable because it interferes with the production of desirable plants. Species composition depends initially on whether a desirable seed source was already present in the soil or if establishment was required. Management activities that determine plant response of an established natural plant community are timing of annual drawdown, depth of flooding, disturbance by disking or plowing, and continuous flooding (fig. 13–55).

Figure 13–54 Enhanced wetlands provide important wildlife habitat in arid landscapes



Maintaining vegetation beneficial to certain species of waterfowl in early succession through frequent soil disturbance or water manipulation may result in a predominantly annual vegetation community with high seed production. After 5 to 7 years, the vegetation will develop seed producing perennials. To reach this goal, disk the area every 3 years for the first 5 to 7 years and less often after that.

Vegetation incompatible with planned objectives may be controlled by disking, burning, mowing, grazing, or biological or chemical procedures. For example, in the Northeast, purple loosestrife can be suppressed with repeated mowings and tillage, but it can be eliminated only by chemicals. The duration and degree of submersion are critical for control if flooding is used. Each control technique must be considered carefully. Prescribed burning must be carefully planned and carried out by a group trained in burning. A prescribed burn plan must be developed before burns are initiated.

In general, there are two types of drawdown, slow and fast. Slow drawdowns occur over a period of 2 weeks or more, and fast drawdowns occur within a few days. Slow drawdowns carried out early in the spring season produce a more diverse vegetative community. Slowly receding water favors diverse species germination. Fast drawdowns early in spring normally produce stands of similar vegetation. Slow drawdowns in late spring produce vegetation of greater diversity and density. Fast drawdowns late in the season may produce less vegetation because of higher soil temperatures when saturated soils become dry. In the South, early drawdown promotes smartweeds during early successional stages and yields greater total seed production. Mid-season drawdowns promote millets. Late season drawdowns promote sprangletop, beggarticks, panicgrass, crabgrass, and higher stem densities. Slow drawdowns produce greater density and diversity than fast drawdowns and prevent the displacement of wetland wildlife that occurs with fast drawdowns. Water level management should be coordinated with the arrival and departure of wildlife species or with habitat conditions, not with a calendar date. Manipulation of undesirable plants should be timed, whenever possible, so that decomposing vegetation can be used effectively by wetland invertebrates. These high protein organisms provide excellent food for waterfowl or shorebirds.

Figure 13-55 Diked wetlands are often designed with various water depths to increase vegetative diversity and allow boat access

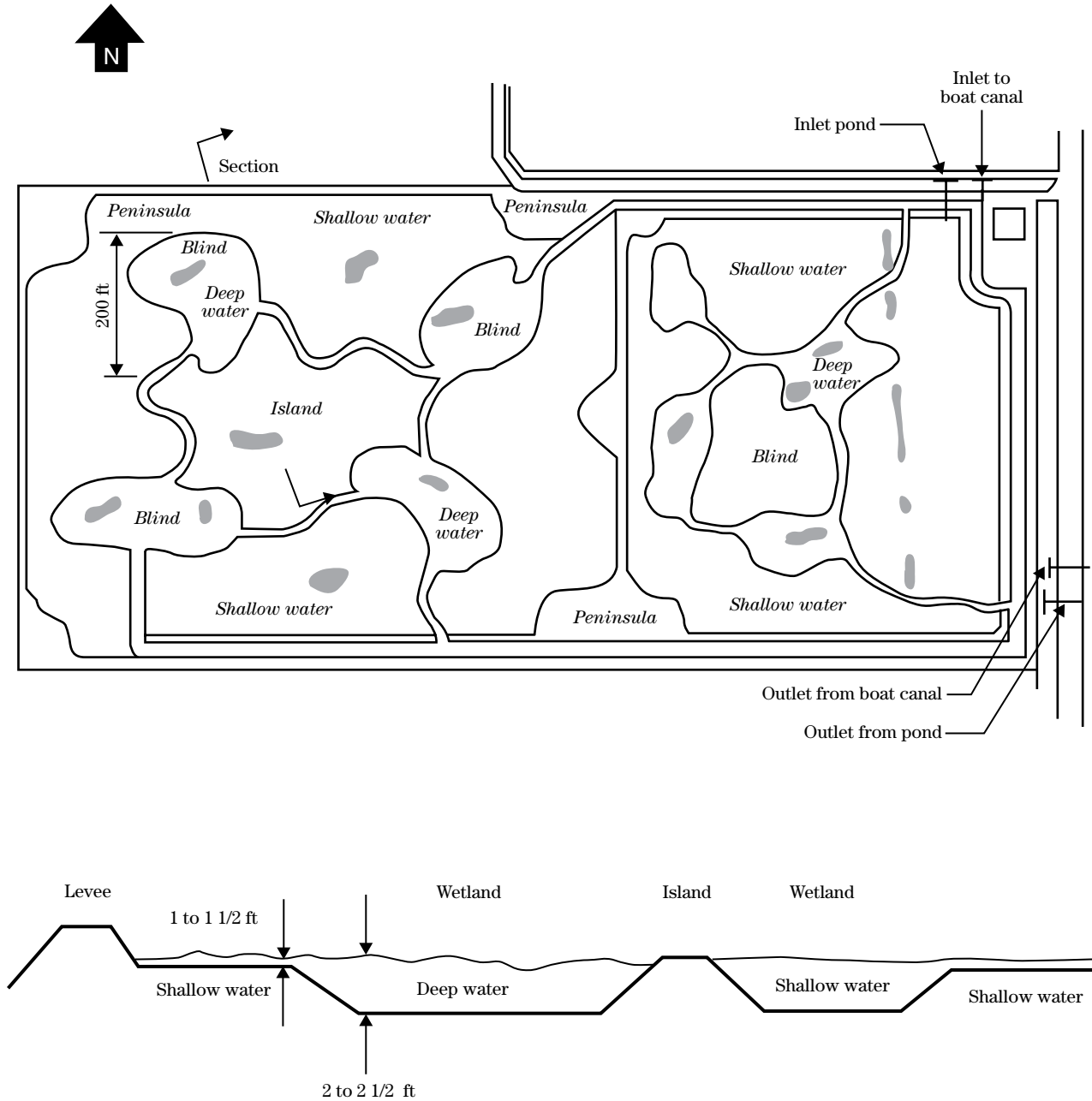

The complexity of water manipulation to manage vegetation emphasizes the importance of frequent monitoring. Frequent inspections allow for timely decisions to control the plant community composition.

Single chemical applications seldom result in complete control of undesirable vegetation. Ground equipment may cause unacceptable damage, and care must be taken to control drift and avoid damage to nontarget species. Herbicide applications are usually costly, as well. Biological control of undesirable vegetation using foraging insects holds promise for some species, but should be planned by professionals in this field.

At northern sites where willow and cottonwood establishment may be undesirable, it may be controlled by mowing followed by shallow flooding. In southern areas, disking during the hottest days of summer can destroy seedlings. Disking two to three times during the growing season may be the most effective means of control. A good practice is to disk the site once every 3 to 4 years to maintain the site in an early successional stage. If larger saplings of up to 3 inches in diameter are present, mowing is an option, but it will not affect root systems. Fall mowing followed by flooding throughout the next growing season may effectively control willow saplings. This flooding should be deep enough to cover all above ground growth. In the South, drawdowns should occur after seed dispersal to confine the establishment of these species to narrower zones of the site.

In years when disking is carried out to regress to early successional stages, or if food plots are desired, several species may be planted that will provide food for waterfowl. Japanese millet, smartweed, browntop millet, and corn are some of the better plantings. In some settings, prescribed burning and livestock grazing can be carried out to favor desirable plants and growth stages or suppress undesirables. Plant communities may be burned off to provide young succulent regrowth for geese and subsequent grazing by livestock to extend the young growth stages. In marshes dominated by giant cutgrass, common reed, and maidencane, periodic moderate to heavy controlled grazing can reduce these plants and favor better seed-producing annuals.

(c) Bottomland hardwood management

Bottomland hardwoods may involve long-term management to achieve desired functions and values (fig. 13–56). In the first few years after reforestation, controlling weeds by disking, mowing, or use of herbicides may speed up the growth of seedlings but benefits will seldom justify the cost. Post-planting weed control may be most critical where a heavy cover of large grasses, such as Johnson grass (*Sorghastrum nutans*—a federally listed noxious weed), or woody vines develops. Consideration should be given to negative effects on wildlife that would use the weeds as food and cover before control measures are implemented. To minimize these impacts, use control measures only if necessary. If wildfire is a danger, create a fire lane around the site annually in early fall. Fertilization may increase growth of some species on old fields or disturbed sites but may not be cost effective from a timber production standpoint. Soils should be tested for nitrogen and phosphorus. It may be better to fertilize in the third or fourth growing season when sufficient root mass is available to compete with grasses and weeds.

Little can be done to protect seedlings from animal predation. Fencing can control domestic livestock, and good site preparation should reduce rodent populations. Only where large populations of beaver or nutria are a problem can protection of individual seedlings be justified. Chicken wire or some other predator guard could be used, especially for cypress plantings.

Figure 13–56 Bottomland hardwoods require many years to achieve desired functions and values



Timber management should provide an abundant and diverse mast crop. Preferred mast trees are water oak, willow oak (*Quercus nigra*), cherrybark oak (*Q. pagoda*), shumard oak (*Q. shumardii*), Nuttall oak (*Q. texana*), and laurel oak (*Q. laurifolia*). Other good mast trees include baldcypress (*Taxodium distichum*), blackgum (*Nyssa sylvatica*), hackberry (*Celtus laevigata*), overcup oak (*Q. lyrata*), swamp white oak (*Q. bicolor*), sweet pecan (*Carya illinoensis*), water tupelo (*Nyssa aquatica*), and green ash (*Fraxinus pennsylvanica*). Management often consists of thinning trees and creating openings. Thinning should be done to encourage mast production through crown development. Thinning can be accomplished by commercial harvesting (timber sales at 10 to 15 years), hand cutting (e.g., for firewood), tree girdling, or herbicide injection. Some dead trees should be left standing to provide nesting sites for wood ducks and other cavity nesting wildlife. Two to four large, supra-canopy individuals and two to four large dead den-trees should be left per acre.

The following considerations should be addressed when managing timber for wildlife:

- To optimize mast production, maintain a basal area of 80 square feet of desirable species per acre. Oaks should occupy from 40 to 60 square feet.
- Maintain a variety of mast producers to ensure acceptable quantities of mast each year.
- Maintain a good distribution of desirable mast producers from seedlings through older timber. Optimum mast production comes from trees with a diameter at breast height of from 14 to 30 inches. A good supply of middle-aged trees will ensure sustained production.
- Create or retain large den trees and snags for nesting wildlife.

Clearings can be created to provide duck foods, such as smartweed, in years when mast crops may fail. Trees on the edge of openings will also have good crown development. Clearings should range from a quarter acre to 5 acres in size. They may be planted to a variety of annual seed producing native species, or corn, grain sorghum, or soybeans if commodity crops are acceptable. State baiting laws should be explained to the landowner when food plots are to be established.

(d) Greentree reservoir/moist soil unit management

Greentree reservoirs are **not** recommended for implementation on extant bottomland hardwood forest stands. Instead, greentrees are only recommended on new restoration sites that are being planted to bottomland hardwoods.

A greentree reservoir is an area of bottomland hardwood that is diked and shallowly flooded during the winter tree dormancy to attract waterfowl. This manipulation of water level is designed to mimic natural bottomland hardwood flooding. Flooding must be scheduled so that tree growth or plant succession is not adversely affected. To avoid timber kill or stress, flooding should not start until October or when the trees have become dormant; whichever is later. Flooding depths should range from 1 to 15 inches. The area must be drained between February and April, depending on the latitude, before the trees begin active spring growth. The greentree reservoir should have the capability of being drained within 1 week. In the South, continual seasonal flooding after 6 to 7 years has reduced hardwood growth rates and encouraged shifts in woody species. Recent studies suggest that greentree reservoirs should not be flooded more than one year in five and should remain dry the remainder of the years.

(e) Ecology of wetland connectivity

Annual flooding in low-gradient rivers and their adjacent flood plain wetlands constitutes a significant subsidy to physical habitat, vegetative communities, and populations of aquatic organisms (Benke et al. 2000). Likewise, seasonal water exchanges between lakes and coastal wetlands and tidal fluxes between salt marshes, estuaries, and shallow marine areas creates and maintains productive habitat for a variety of plants and animals (Stevens et al. 2006). Most freshwater and many marine aquatic organisms utilize wetland environments at some stage of their development (Mitsch and Gosselink 1993). However, for these developmental and ecological benefits to be realized aquatic habitats must be connected to adjacent rivers, lakes, and coastal areas, and aquatic organisms must be able to move between and within these habitats. Providing passage into and out of annually or seasonally flooded areas adjacent to rivers, lakes, and oceans may be an

essential element in the recovery of native at-risk species, as well as a mechanism to reduce the impacts of nonnative species (Barko et al. 2006).

In dynamic environments (rivers, streams, lakes, and coastlines), the location, quality, and quantity of aquatic habitats changes over time. For example, in riverine ecosystems, flowing water and the materials it carries (sediment and large woody material) combine to shape the river channel, its banks, and adjacent flood plain surfaces, creating a shifting habitat mosaic (Stanford et al. 2005). In large rivers with extensive flood plains, annual overbank flood pulses are essential hydrologic features governing year-to-year changes in ecosystem productivity and biological diversity (Junk et al. 1989; Ward 1989; Welcomme 1985). Interaction between the river and its flood plain facilitates the lateral exchange of nutrients, organic matter, and aquatic organisms between the main channel and backwaters, oxbow lakes, and wetlands (Benke and Meyer 1988; Meyer 1990; Sparks et al. 1990). This, in turn, increases the biological activity of the river ecosystem (Bayley 1989; Junk et al. 1989; Meyer 1990) and expands the physical habitat and food sources available for fishes and aquatic invertebrates (Welcomme 1989; Reimer 1991; Bischoff and Wolter 2001; Flotemersch and Jackson 2003). Flood plain interactions contribute to increased food intake and growth rates in most river fishes and may account for up to 75 percent of annual growth (Welcomme 1985).

Seasonal water flux between lake water and adjacent marshes is an essential feature in the life history of many freshwater organisms. For example, some 47 species of fish found in the Lake Erie ecosystem are associated with coastal wetlands during some stage of their life history (Johnson 1989). Tidal pulsing is also important in salt marshes (Niering 1994; Turner and Lewis 1997; Zedler and Callaway 1999) and mangrove swamps (McKee and Faulkner 1999). Restoring connectivity or providing passage structures into and out of these wetland habitats can yield substantial ecological benefits in terms of water quality, species demography, and physical habitat (Mitsch and Gosselink 1993; Brinson and Malvarez 2002; Wells et al. 2002; Stevens et al. 2006).

(1) Movement timing and strategies

Movement or migration timing can be predictable for some aquatic organisms, is generally daily or seasonal, and varies according to species. In addition, migra-

tion and movement can be affected by environmental conditions. For example, seasonal spawning migrations in riverine fishes can be influenced by water temperature, velocity, and water clarity. Conversely, other aquatic organisms move or migrate in direct response to changing conditions (food availability, temperature, oxygen levels, water levels, and flow velocities) either to take advantage of opportunities such as access to flood plains, or to avoid adverse conditions.

Generally, all animal species within aquatic ecosystems must move for populations to persist. Movement and migration can occur in four dimensions—up, down, across, and into streams, wetlands, coastal areas, and the sediments composing their bed, banks, and shores. Some aquatic organisms are capable of moving or burrowing only short distances, unless displaced by floods or when attached to other animals or woody debris. Others are strong swimmers (migratory fish) with the capacity for long-distance movements and the ability to move upstream against strong currents. Between these two mobility extremes exists a variety of species—some mostly sedentary, but with the capacity for strong bursts of swimming, and others (some crayfish) that are capable of long-distance movements, typically crawling rather than swimming.

Swimming ability is quite variable within and among fish species. Relatively abundant data exists that describe the swimming performance of strong swimmers such as salmonids (Bell 1991), but surprisingly little is known about most other fish species, especially the juvenile life stage (Adams et al. 2000). Vastly less is known about the swimming abilities of nonfish species that inhabit many riverine and wetland environments. Many relatively large aquatic animals that commonly move around aquatic habitats are rarely considered with respect to their passage requirements or when assessing movement barriers (Jackson 2003). Examples include mudpuppies, waterdogs, hellbenders, sirens, and amphiuma—all fully aquatic salamanders that range in adult size from about a foot to more than 3 feet in length. In addition, the Oklahoma salamander and the Pacific giant salamanders of the West Coast are other aquatic or semiaquatic amphibians that are vulnerable to movement barriers.

Many regions of the United States support softshell and musk turtles—aquatic reptiles that rarely travel over land. Compared to migratory fish, amphibians and reptiles are not strong swimmers, yet movement

and demographic continuity are essential to population and species survival. Crayfish, significant components of many lowland freshwater ecosystems, have been documented moving long distances within streams and likely require unimpeded, relatively smaller scale movements to maintain continuous and interconnected populations (Jackson 2003). For example, Findlay and Houlihan (1997) found that the diversity of birds, reptiles, amphibians, and plants in 30 Ontario wetlands was negatively correlated with the density of paved roads on land up to 1.2 miles from the wetlands (Findlay and Houlihan 1997). They determined that an increase in hard-surface road density of less than 1 linear mile per acre would have approximately the same impact on species richness as the loss of half the wetland area. Further, Findlay and Bourdages (2000) speculated that significant negative relationships between passage barriers and species richness observed may have occurred decades ago, shortly after road networks isolated wetland sites.

(2) Passage challenges and solutions

As outlined in the preceding paragraphs, any feature or management practice that provides conditions outside of the swimming, crawling, slithering, or walking abilities of an aquatic organism will likely provide insurmountable passage challenges. In wetland settings, these passage challenges often exist in the form of road and railway prisms, dikes, levees, dams, flood and tide gates, and bulkheads—again, any feature or management practice that interferes with the natural

hydrologic cycle or exceeds the dimension and geometry of naturally occurring hydraulic features.

A simple approach to ensuring that aquatic organism passage is adequately addressed in wetland restoration activities is to identify the timing, duration, and frequency of aquatic animal migrations; understand their means of locomotion (swimming or crawling); analyze the physical variables that preclude passage (velocity, substrate size and composition, and leaping ability); and apply passage technology that provides the best possible chance of meeting all of an aquatic organism's movement needs and mobility. For example, aquatic turtles may require culverts through an embankment or under a roadway that matches or exceeds their body size and is inundated during major movement or migration periods—this passage approach requires no extensive velocity calculations and may be cost effective. Granted, complex assemblages of target taxa combined with fluctuating water levels and detailed operational scenarios can lead to situations where tough decisions must be made. However, if planners strive to mimic natural hydrology and physical habitat to the fullest extent possible, any passage feature should provide unimpeded movement for a diverse array of fish, amphibians, reptiles, and crustaceans. Table 13–11 outlines general passage barriers found in and around wetland settings, common passage technologies, their range of applicability, and suggested references for additional information.

Table 13–11 Passage barriers and solutions

Barrier type	Passage technology	Applicability	References
Road and railway prisms	Bridges, culverts, causeway	Fish, amphibians, reptiles, crustaceans	WDFW 2003
Dikes, levees, bulkheads	Rock ramps, constructed riffles, step-pool structures,	Fish	Jungwirth et al. 1998; WDFW 2003
	Culverts, self-regulating gates, automated gates	Fish, amphibians, reptiles, crustaceans	
Dams	Fish ladders, Alaska Steeppass or denils	Fish, some amphibians and crustaceans	Powers et al. 1985; Clay 1995; WDFW 2000
Tidegates and floodgates	Automated or self-regulating gates	Fish, amphibians, reptiles, crustaceans	Charland 1998; Giannico and Souder 2004

(f) Herpetofauna

(1) General requirements

Reptiles and amphibians are collectively referred to as herpetofauna or herps. Herps can be habitat specialists constrained to specific habitat attributes, or habitat generalists able to exploit a multitude of habitat types and conditions. The complexity of trying to restore and manage wetlands for both the habitat generalist and specialist can become cumbersome. This problem is often resolved by selecting a subset of species that are spatially and heterogeneity demanding, commonly termed umbrella species, to set targets for restoration and management. This method follows the hypothesis that if the most demanding species needs are met, then less demanding species should be provided for by default. The following sections provide basic information on providing suitable herp habitat in a broad context. At a minimum, providing access to food, shelter, and migration corridors, as well as hibernation, aestivation, breeding, and nesting sites should be covered in restoration and management plans. For specific habitat needs of a particular species, careful research and consultation with local experts will need to be undertaken and melded into the wetland plan and design.

(2) Hydrology considerations

Various herpetofauna utilize seasonally flooded (30 to 90 days of inundation) pools, while others prefer semipermanently or permanently inundated habitats. Timing of wetland inundation is just as important as length of inundation in determining herp use of wetlands. For example, amphibians partake in resource partitioning, sequencing their breeding activities within pools when suitable conditions occur. Early breeding amphibians utilize pools late winter through early spring, while mid-season breeders utilize pools from mid to late spring and are followed by late season summer breeders. For a wetland to house all three of these groups, the appropriate breeding habitat must be available at the right time and for the right duration.

Wetlands suitable for inhabitation by herps (fig. 13–57) in wet years may be rendered unsuitable in dry years due to natural drought cycles and vice versa. To account for this, wetlands with diverse water regimes should be restored with hydroperiods falling within natural variability of wetlands found within the area. Wetlands should be placed no further than 300 meters from a permanent water source to provide herps with

water and emigration corridors during drought periods.

Manipulation of wetland water levels could have adverse effects on herps if conducted during inopportune times. Water levels should not be manipulated during the breeding or hibernation seasons, a practice that may result in the desiccation and death of hibernating herps or amphibian eggs and larvae. Impounding water during these times may also pose concerns and could result in the inundation of upland nesting areas or change the thermal dynamics and oxygen content of underwater hibernacula.

(3) Vegetation requirements

As a general rule, amphibians prefer habitat with a canopy cover which provides shaded, cool, moist environments under which considerable amounts of litter develop. Many salamander species have been found to prefer habitats with low edge to volume ratios, whereas species richness of frogs and toads has been found to be higher within sites having a great deal of habitat edge. Reptiles on the other hand, generally prefer drier, more open habitats with thermal gradients from which they can choose to exploit. Managing habitat for reptiles may require mechanical or biological treatments of vegetation or the use of prescribed fire to open the canopy to provide thermal gradients and basking habitat.

Figure 13–57 Herpetofauna, such as turtles, utilize wetlands for all or a part of their life cycle



Creating a mosaic of wetlands varying in shape, depth, vegetative community and proximity to each other will spatially and temporally provide herpetofaunal habitat. Gradual side slopes ($\geq 20\text{H}:1\text{V}$ optimal) will maximize the extent of shallow wetland habitats ($< 4\text{--}6$ in) that are the most attractive to a broad range of herpetofauna. A very dense herbaceous stand may pose a barrier to herp movement and may offer too little basking habitat for reptiles. Seeding sites with a mix of plants including forbs, short-grasses, and sedges along with big grasses will promote open vegetative canopies with interstitial space more conducive to herpetofaunal movement and basking. In addition, vegetation management by way of mechanical means (disking or mowing) or managed grazing practices may increase the quality of a vegetative stand for herpetofaunal purposes if they occur on a rotational basis and are sensitive to herpetofaunal activity periods. If mechanical means are to be implemented, disking should be no deeper than 6 inches, and vegetation should not be mown shorter than 12 inches. In addition, mechanical means should not disturb nesting areas, cover objects, or hibernacula during critical periods.

Cover objects are commonly missing in traditional restoration plans. Cover objects have a dual purpose in providing aboveground basking platforms as shown in figure 13-58 and belowground shelter from climat-

ic extremes and predators. Cover objects also concentrate invertebrates and become an important feeding area for insectivorous herpetofauna. Cover objects can be provided in the form of logs, rocks, boards, brush or rock piles, etc., scattered throughout core habitat, along corridors or edges, and partially in or under water and should have varying solar aspects. It is very important that cover objects be scattered along the length of corridors to protect migrating herps from desiccation and predation. For cover objects to act as basking platforms within herbaceous vegetation, be sure to choose objects wider than the height of the surrounding vegetation to reduce the extent of shading. The development of suitable conditions (temperature, humidity, etc.) under cover objects may take a considerable amount of time; therefore, disturbance of such habitat should not occur.

(4) Hibernacula

Hibernacula are overwintering sites utilized by herpetofauna. Upland-associated species may hibernate under cover objects, within deep litter, under loose tree bark, or underground in burrows. Many aquatic species burrow into the bottom sediments and debris within wetlands, while others hibernate within muskrat mounds, beaver dams, or crayfish burrows. Hibernacula can be designed and constructed to provide overwintering habitat for herps. It is important to

Figure 13-58 Rock basking structure

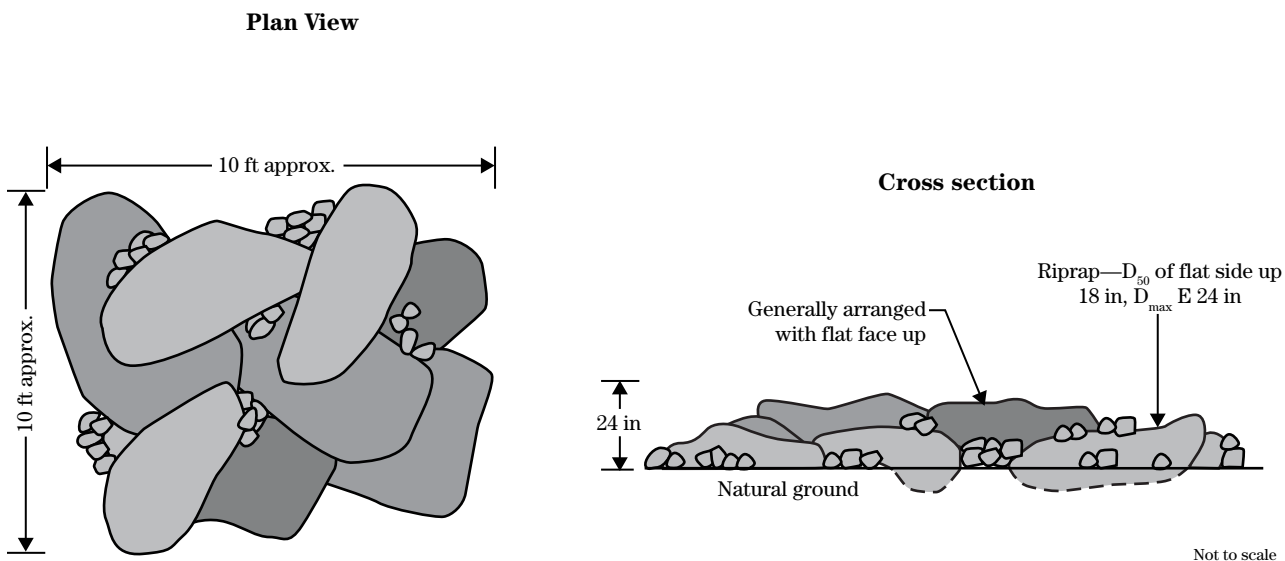

note that hibernacula need to extend below the low water table elevation if aquatic species such as water snakes or frogs are expected to make use of it. Figures 13-59 and 13-60 provide examples of hibernacula.

(5) Movement, barriers, and corridors

Due to the weak dispersal capabilities of many herps, emigration of animals during and immigration of animals post restoration/management is most successful for sites within 300 meters of suitable untreated habitat. Therefore, it is advised that a site be managed on a rotational basis with no more than a fourth of any

one habitat type impacted in any given year. Optimally, core habitat should be protected within a 300-meter radius of the wetland edge and be encompassed by a 50-meter buffer zone. The design or preservation of travel corridors to facilitate everyday home range movements, seasonal and breeding migrations, dispersal, and range shifts in response to environmental and climatic changes should also be carefully planned. The effectiveness of wildlife corridors increases with width and in proximity to riparian areas. Herp movements are not random, but are usually directional, making careful placement of corridors vital, especial-

Figure 13-59 Rock hibernacula

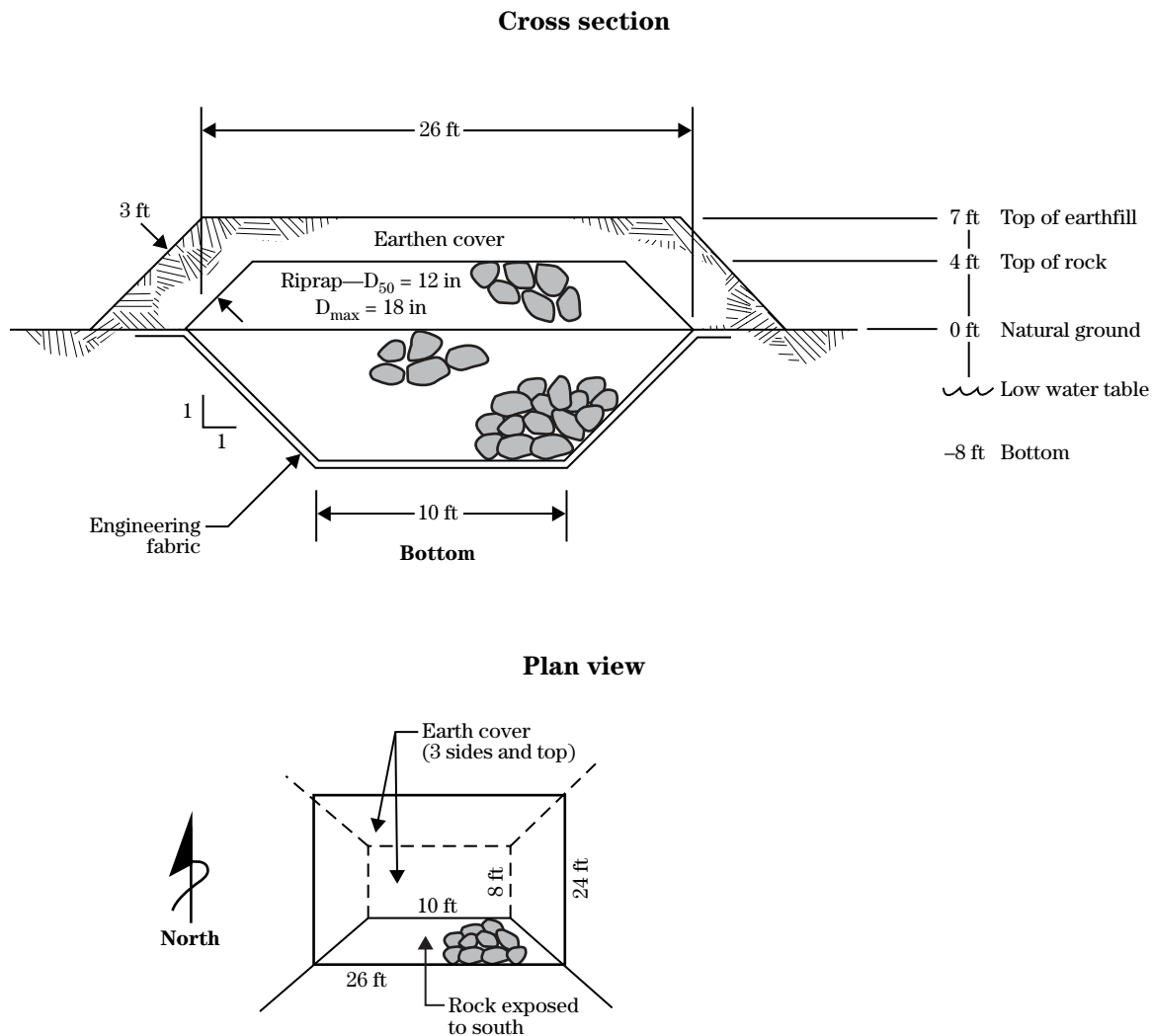
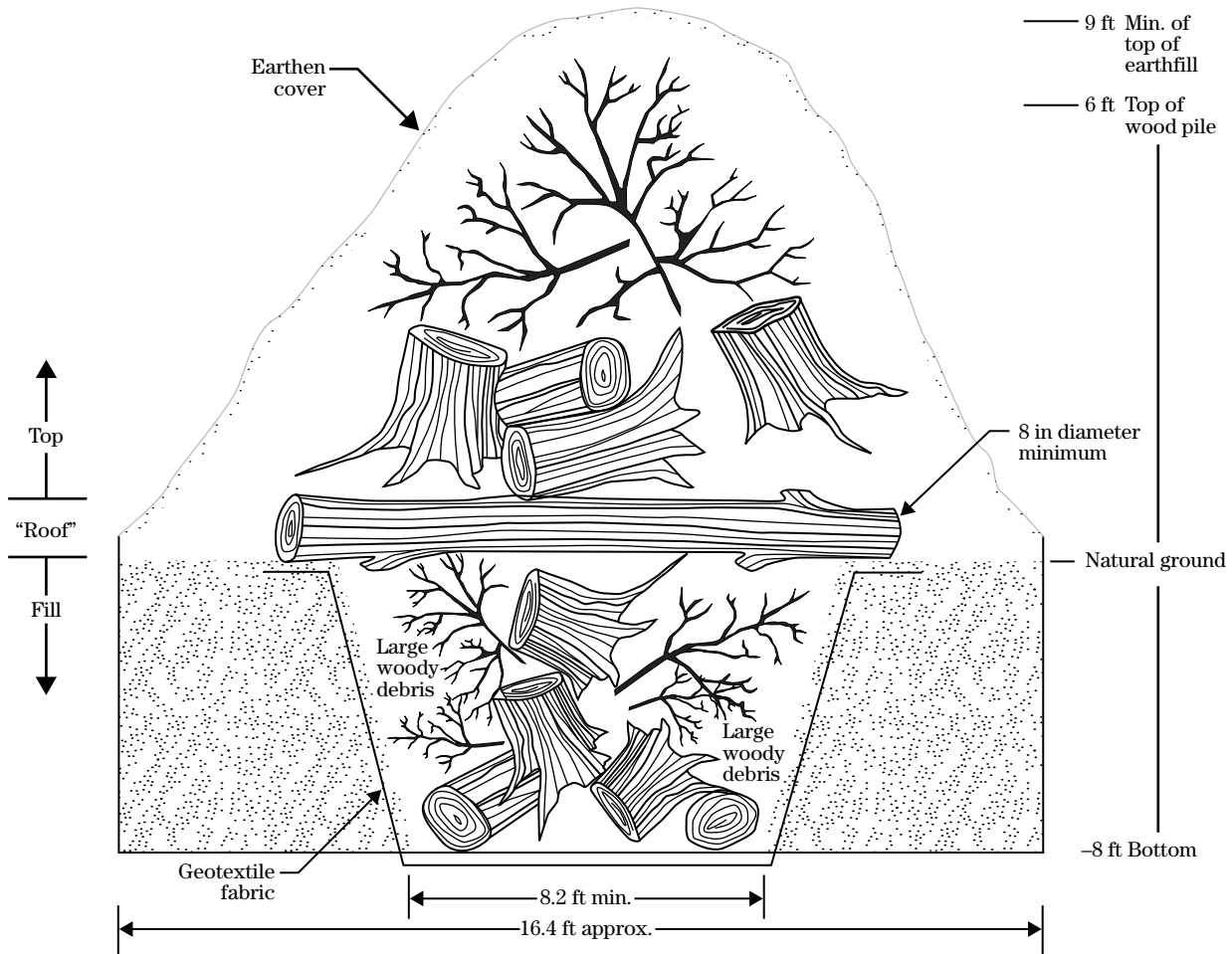
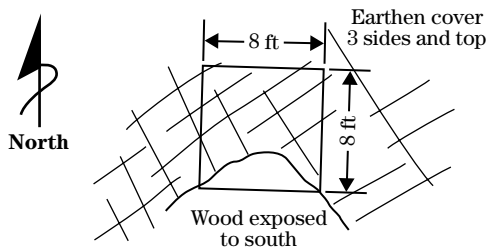

Figure 13-60 Wood hibernacula

Cross section



Plan view



Not to scale

ly where barriers lie between riparian breeding or hibernation grounds and upland habitats. In areas with high road density, safe passage (road barriers and safe crossings) should be provided for herps, particularly in areas where roads bisect high use travel corridors. Barriers that run parallel to roads may be constructed to prevent herps and other wildlife from crossing roads, thus reducing animal mortality and road hazards.

(6) Habitat considerations

Herpetofaunal habitat may be degraded as a result of inappropriate or poorly timed land use or management practices or through the removal of natural ecological processes (fire, hydrology, flooding, large mammalian grazers) which create and maintain ecological diversity. The removal of such stressors and/or the reintroduction of natural ecosystem maintenance processes can have a significant impact on the quality of habitat for herp species.

Poor water quality conditions may pose health concerns and have significant effects on the reproductive success of wetland breeding herpetofauna. Urban, industrial, and agricultural pollutants (nutrients, sediments, pesticides, heavy metals, and organo-chemicals) should be addressed prior to and post restoration to ensure that these substances do not exceed acceptable levels.

Fish and bullfrogs should not be introduced into natural or restored habitats that do not or did not naturally

house these species. Predatory fish and bullfrogs will eat amphibian eggs, larvae, and adults; therefore, most amphibians require wetlands devoid of these predators. In addition, several studies have found that the presence of nonpredatory fish in breeding pools can reduce larval survival of many amphibians by disrupting predator avoidance behaviors. Fish and bullfrogs can be excluded from and controlled within a restoration by minimizing permanent water and by creating stands of water that are shallow enough to cause hypoxia and desiccation during drought years.

Suitable reptilian nesting habitat may be created by providing cover objects, den trees, or removing/reducing overgrown vegetation on sandy soils on slopes with south and west facing aspects. Fence rows, tree lines, or shrub or tree encroachment that penetrate core turtle nesting habitat may increase the risk of nest predation by fox, skunk, raccoon, or other edge associated predators. In such cases, these fragmenting habitats should be removed and kept a minimum of 50 to 60 meters away from the nesting grounds. Figure 13–61 illustrates a simple reptile nesting structure.

Amphibian breeding ponds should be monitored for water quality to determine whether the site provides a safe environment for developing eggs, larvae, and aquatic adults. Many amphibian species attach eggs to submerged vegetation and debris, habitat attributes that should be provided if not naturally present.

Figure 13–61 Reptile nesting structure

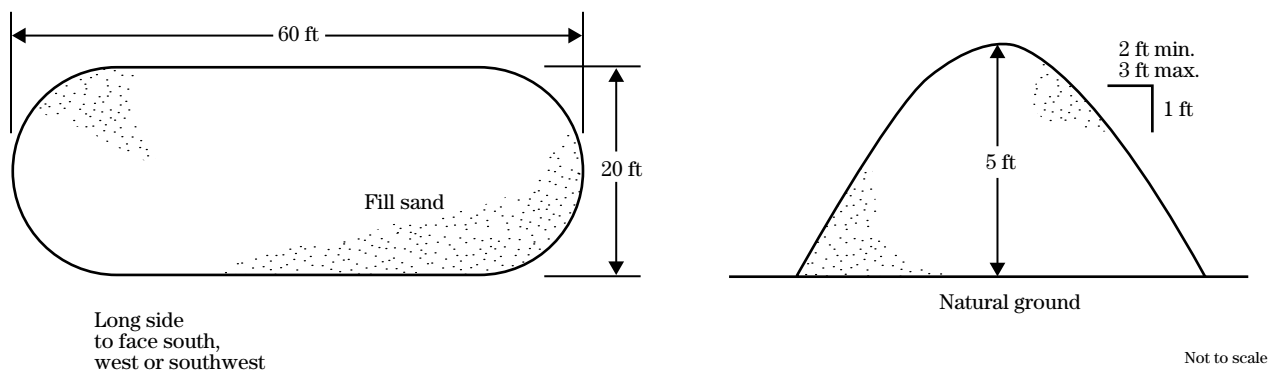

(7) Additional construction details

Listed are additional details for herpetofauna habitat structures:

Safe crossings and barriers—There are a variety of road barriers in use, ranging from fencing and sheet piling to concrete walls. Road barriers may be used in conjunction with preexisting (culverts, bridges, etc.) or constructed “safe crossings” to route wildlife to safe passageways under or over roadways.

Hibernacula—hibernacula are structures that provide shelter for hibernating reptiles, whether it be leaf litter, rock crevices, burrows loose bark, etc. There are several designs available for constructing underground hibernacula for snakes which could also benefit other wildlife (figs. 13–59 and 13–60).

Large hibernaculum design—

Step 1 Dig a hole 10 feet wide by 15 feet long by 6 to 10 feet deep.

Step 2 Fill the hole with logs, rocks, and debris in a pile 4 feet higher than ground level.

Step 3 Place rock on the south facing side of the hibernacula.

Step 4 Cover all but the south facing side of rock with 3 feet of soil.

Step 5 Over-seed the mound with native vegetation.

Small, culvert hibernacula design—

If space and materials are lacking, utilize a 36-inch cement culvert pipe, riprap, flagstone, and engineering fabric according to the following steps.

Step 1 The culvert pipe, with the bottom covered with engineering fabric, should be set into a hole at least 7 feet deep and be several feet below the high water table if placed within wetland or riparian areas.

Step 2 Fill the culvert pipe with riprap or broken concrete that is free of reinforcement.

- Loosely place flagstone or flat rocks 2 feet high over the top of the culvert.

Brush piles—Brush piles provide shelter from wind, rain, and other environmental stressors.

Step 1 Construct brush piles 15 feet wide by 15 feet long by 8 feet high in size and number three to four per acre and may be placed randomly on land or partially submerged at the waters edge.

Step 2 Design the foundation of the pile with 6- to 10-inch-diameter logs placed parallel to each other 1 foot apart (old pallets make excellent foundations for a brush pile).

Step 3 Place branches and logs in perpendicular layers on top of the foundation.

Step 4 Place smaller debris on top of the branches to form a mound.

Rock piles—If desired, place chimney tile, old clay field tile, or lengths of pipe on the ground so that they are accessible from the edge of the finished pile.

Step 1 Pile rocks (riprap and concrete) of differing shapes and sizes to the desired height.

Step 2 Finish by angling several 4- to 6-inch-diameter logs or flat rocks over the rock pile.

650.1307 References

- Adams, S.R., J.J. Hoover, and K.J. Killgore. 2000. Swimming performance of the Topeka shiner (*Notropis topeka*) an endangered midwestern minnow. *American Midland Naturalist* 144:178–186.
- Allen, H.H., and C.V. Klimas. 1986. Reservoir shoreline revegetation guidelines. Technical Report E–86–13. U.S. Army Corps of Engineers Waterways Experiment Station, Vicksburg, MS. 87 pp.
- Allen, J.A., and H.E. Kennedy, Jr. 1989. Bottomland hardwood reforestation in the lower Mississippi Valley. U.S. Department of Agriculture, Forest Service. Stoneville, MS. 29 pp.
- Austin, R.L. 1984. Designing the natural landscape. Van Nostrand Reinhold Co., Inc. New York, NY. 117 pp.
- Baber, M.J., D.L. Childers, K.J. Babbitt, and D.H. Anderson. 2002. Controls on fish distribution and abundance in temporary wetlands. *Can. J. Fish. Aquat. Sci.* 59:1441–1450.
- Barko, V.A., D.P. Herzog, and M.T. O’Connell. 2006. Response of fishes to floodplain connectivity during and following a 500-year flood event in the unimpounded upper Mississippi River. *Wetlands*. 26(1):244–257.
- Bayley, P.B. 1991. The flood pulse advantage and the restoration of river-floodplain systems. *Regulated rivers: Research and Management* 6:75–86.
- Bayley, P.B. 1989. Aquatic environments in the Amazon basin, with an analysis of carbon sources, fish production, and yield. pp 399–408. *In* Proceedings of the International Large River Symposium (LARS). D.P. Dodge (ed.). Canadian Special Publication of Fisheries and Aquatic Sciences 106. Canadian Department of Fisheries and Oceans, Ottawa, Canada.
- Bell, M.C. 1991. Fisheries handbook of engineering requirements and biological criteria. Fish Passage Development and Evaluation Program, U.S. Army Corps of Engineers, North Pacific Division. Portland, OR. 290 pp.
- Benke, A.C., and J.L. Meyer. 1988. Structure and function of a blackwater river in the southeastern USA. *Internationale Vereinigung für Theoretische und Angewandte Limnologie, Verhandlungen* 23:1209–1218.
- Benke, A.C., I. Chaubey, G.M. Ward, and E.L. Dunn. 2000. Flood pulse dynamics of an unregulated river floodplain in the Southeastern U.S. Coastal Plain. *Ecology*. 81(10) 2730–2741.
- Bischoff, A., and C. Wolter. 2001. The flood of the century on the River Oder: Effects on the 0+ fish community and implications for floodplain restoration. *Regulated Rivers: Research and Management* 17:171–190.
- Brinson, M.M. 1993. A Hydrogeomorphic Classification for Wetlands. U.S. Army Corps of Engineers. Technical Report WRP–DE–4. Washington, DC. 67 pp. + app.
- Brinson, M.M., and A.I. Malvarez. 2002. Temperate freshwater wetlands: types, status, and threats. *Environmental Conservation* 29:115–133.
- Cantrell, L. 2001. Evaluation of ditch plug designs and construction methods for the blocking of field ditches to restore wetland hydrology in the Coastal Plains of South Carolina. Proceedings: ASAE Annual International Meeting, Paper Number 01–2058, American Society of Agricultural and Biological Engineers, Sacramento, CA. 9 pp.
- Charland, J.W. 1998. Tide gate modifications for fish passage and water quality enhancement. Tillamook Bay National Estuary Project, Garibaldi, OR.
- Clay, C.H. 1995. Design of fishways and other fish Facilities. Second Edition. CRC Press, Inc. Boca Raton, FL. 248 pp.

- Findlay, C.S., and J. Bourdages. 2000. Response time of wetland biodiversity to road construction on adjacent lands. *Cons. Biol.* 14(1):86–94.
- Findlay, C.S., and J. Houlahan. 1997. Anthropogenic correlates of species richness in Southeastern Ontario wetlands. *Cons. Biol.* 11:1000–1009.
- Flotemersch, J.E., and D.C. Jackson. 2003. Seasonal foraging by channel catfish on terrestrially burrowing crayfish in a floodplain-river ecosystem. *Ecohydrology and Hydrobiology* 3(1):61–70.
- Forman, R.T., and M. Godron. 1986. *Landscape Ecology*. John Wiley & Sons, Inc. 530 pp.
- Fredrickson, L.H., and F.A. Reid. 1988. Control of willow and cottonwood seedlings in herbaceous wetlands. *Waterfowl Management Handbook*. U.S. Fish and Wildlife Service. Leaflet 13. Washington, DC. 3 pp.
- Fredrickson, L.H., and F.A. Reid. 1988. Preliminary considerations for manipulating vegetation. *Waterfowl Management Handbook*. U.S. Fish and Wildlife Service. Leaflet 13. Washington, DC. 6 pp.
- Fredrickson, L.H., and T.S. Taylor. 1988. Management of seasonally flooded impoundments for wildlife. Resource Publication 148. U.S. Fish and Wildlife Service. Washington, DC. 30 pp.
- Gergel, S.E., and M.G. Turner. 2002. *Learning landscape ecology: a practical guide to concepts and techniques*. Springer-Verlag. NY. 316 pp.
- Giannico, G.R., and J.A. Souder. 2004. The effects of tide gates on estuarine habitats and migratory fish. Oregon State University, Oregon Sea Grant Publication ORESU-G-04-002. Corvallis, OR.
- Gray, D.H., and A.T. Leiser. 1982. *Biotechnical slope protection and erosion control*. Van Nostrand Reinhold Co. Inc., NY. 265 pp.
- Jackson, S.D. 2003. Overview of transportation impacts on wildlife movement and populations. *In Wildlife and Highways: Seeking Solutions to an Ecological and Socio-economic Dilemma*. T.A. Messmer and B. West (eds.). The Wildlife Society. pp. 7–20.
- Jacobson, A.M. 1986. Wetland restoration: a tool in wetland preservation. *Proceedings: National Wetland Symposium; Mitigation of Impacts and Losses*. Technical Report 3. Association of State Wetland Managers. Berne, NY. pp 207–210
- Johnson, D.L. 1989. Lake Erie wetlands: fisheries considerations. *In Lake Erie and its estuarine systems: Issues, resources, status, and management*. K.A. Krieger (ed.). NOAA Estuary of the Month series No. 14, May 4, 1988. Washington DC. pp. 257–276.
- Johnson, R.L. No date. Guidelines for planting hardwood trees in southern bottomland fields. U.S. Department of Agriculture, Forest Service. Stoneville, MS. 2 pp.
- Jungwirth, M., S. Schmutz, and S. Weiss (eds.). 1998. *Fish migration and fish bypasses*. Fishing News Books, Oxford, United Kingdom. 438 pp.
- Junk, W.J., P.B. Bayley and R.E. Sparks. 1989. The flood pulse concept in river-floodplain systems. *In Proceedings of the International Large River Symposium*. D.P. Dodge (ed.). Can. Spec. Publ. Fish. Aquat. Sci., 106. pp. 110–127.
- King, A.J., P. Humphries, and P.S. Lake. 2003. Fish recruitment on floodplains: the roles of patterns of flooding and life history characteristics. *Canadian Journal of Fisheries and Aquatic Sciences* 60:773–786.
- Kusler, J.A., and M.E. Kentula (eds.). 1989. *Wetland creation and restoration, the status of science*. Island Press, Washington, DC. 594 pp.
- Kwak, T.J. 1988. Lateral movement and use of floodplain habitat by fishes of the Kankakee River, Illinois. *Am. Midland Naturalist* 120(2):241–249.

- Landin, M.C., J.W. Webb, and P.L. Knutson. 1989. Long-term monitoring of eleven Corps of Engineers habitat development field sites built of dredged material, 1974–1987. Technical Report D–89–1. U.S. Army Corps of Engineers Waterways Experiment Station, Vicksburg, MS. 192 pp.
- Landin, M.C., A. Dardeau, and M.P. Rollings. 1990. Guidelines for wetland restoration and establishment for mitigation. Technical Report D–90–, in draft. U.S. Army Corps of Engineers Waterways Experiment Station, Vicksburg, MS. 200 pp.
- Landin, M.C. (ed.). 1988. Inland waterways: a National workshop on the beneficial uses of dredged material. October 1987. St. Paul, MN. Technical Report D–88–8. U.S. Army Corps of Engineers Waterways Experiment Station, Vicksburg, MS. 291 pp.
- Lyle, J.T. 1985. Design for human ecosystems. Van Nostrand Reinhold Co. Inc. New York, NY. 270 pp.
- McKee, K.L., and P.L. Faulkner. 1999. Biogeochemical functioning of restored and natural mangrove forests in Southwest Florida. Final Report to NOAA/NERRS/SRD. National Wetlands Research Center. Lafayette, LA.
- Meyer, J.L. 1990. A blackwater perspective on riverine ecosystems. *BioScience* 40(9):643–651.
- Mitsch, W.J., and J.G. Gosselink. 1993. *Wetlands*, 2nd edition. Van Nostrand Reinhold, NY.
- Niering, W. 1994. Wetland vegetation change: a dynamic process. *Wetland Journal* 6:6–15.
- Pearsons, T.N., H. Li, and G. Lamberti. 1992. Influence of habitat complexity on resistance to flooding and resilience of stream fish assemblages. *Trans. Amer. Fish. Soc.* 121:427–436.
- Powers, P.D., J.F. Orsborn, T.W. Bumstead, S. Klinger-Kingsley, and W.C. Mih. 1985. Fishways—an assessment of their development and design. U.S. Department of Energy No. DOE/BP–36523–4. Bonneville Power Administration. Portland, OR.
- Prichard, D. 1999. Riparian area management: a user guide to assessing proper functioning condition and the supporting science for lentic areas. TR 177–16. U.S. Bureau of Land Management, BLM/RS/ST–99/001+1737. 109 pages.
- Quarman, M.L. 1986. Measuring the success of wetland mitigation. Proceedings: National Wetland Symposium; Mitigation of Impacts and Losses. Technical Report 3. Association of State Wetland Managers. Berne, NY. pp. 242–245.
- Reimer, G. 1991. The ecological importance of floodplains for fish at the river March (Austria). *Archives of Hydrobiology* 121:355–363
- Richards, C., P. Cernera, M. Ramey, and D. Reiser. 1992. Development of off-channel habitats for use by juvenile Chinook salmon. *N. American Journal of Fish Management* 12:721–727
- Richardson, J.L., and M.J. Vespraskas. 2001. *Wetland soils*. Lewis Publishers, Boca Raton, FL. 417 pp.
- Rosgen, D. 1996. *Applied River Morphology*. Printed Media Companies, Minneapolis, MN.
- Smith, R.D., A. Ammann, and C. Bartoldus. 1995. An approach for assessing wetland functions using hydrogeomorphic classification, reference wetlands, and functional indices. Technical Report WRP–DE–9. U.S. Army Corps of Engineers Waterways Experiment Station, Vicksburg, MS. 71 pp.
- Snodgrass, J.W., A.L. Bryan, Jr., R.F. Lide, and G.M. Smith. 1996. Factors affecting the occurrence and structure of fish assemblages in isolated wetlands of the upper coastal plain, USA. *Can. J. Fish. Aquat. Sci.* 53:443–454.
- Spangler, M.G., and R.L. Handy. 1982. *Soil Engineering*, Fourth Edition. Harper and Row. New York, NY.
- Sparks, R.E., P.B. Bayley, S.L. Kohler, and L.L. Osborne. 1990. Disturbance and recovery of large floodplain rivers. *Environmental Management* 14:699–709.

- Stanford J.A., M.S. Lorang, and F.R. Hauer. 2005. The shifting habitat mosaic of river ecosystems. *Verhandlungen der Internationalen Vereinigung für Theoretische und Angewandte Limnologie* 29: 123–136.
- Stevens, P.W., C.L. Montague, and K.J. Sulak. 2006. Patterns of fish use and piscivore abundance within a reconnected saltmarsh impoundment in the northern Indian River Lagoon. *Florida Wetlands Ecology and Management*. 14:147–166.
- The Conservation Foundation. 1989. *Protecting America's wetlands: an action agenda*. Washington, DC. 69 pp.
- Thompson, D.Q. 1989. Control of purple loosestrife. *Waterfowl Management Handbook*. U.S. Fish and Wildlife Service. Leaflet 13. Washington, DC. 6 pp.
- Turner, M.G., R.H. Gardner, R.V. O'Neill. 2001. *Landscape ecology in theory and practice: pattern and process*. Springer-Verlag New York, Inc. NY. 401 pp.
- Turner, R.E., and R.R. Lewis III. 1997. Hydrologic restoration of coastal wetlands. *Wetlands Ecology and Management* 4:65–72.
- U.S. Army Corps of Engineers, Waterways Experiment Station, Environmental Laboratory. 1978. *Wetland habitat development with dredged material: engineering and plant propagation*. Technical Report DS-78-16. Vicksburg, MS. 107 pp.
- U.S. Army Corps of Engineers, Waterways Experiment Station, Environmental Laboratory. 1986. *Field guide for low maintenance vegetation establishment and management*. Instruction Report R-86-2. Vicksburg, MS 111 pp + app.
- U.S. Army Corps of Engineers. 1986. *Dredged material—beneficial uses*, by M.C. Landin. Engineer Manual 1110-2-5026. Office, Chief of Engineers, Washington, DC. 297 pp.
- U.S. Bureau of Reclamation. 1997. *Water Measurement Manual, Third Edition*, Washington, DC.
- U.S. Department of Agriculture, Agricultural Research Service. 1987. *Agricultural Handbook Number 667, Stability Design of Grass-Lined Open Channels*.
- U.S. Department of Agriculture, Natural Resources Conservation Service. 1993. *Agriculture Handbook Number 18, Soil Survey Manual*. Washington, DC. 437 pp.
- U.S. Department of Agriculture, Natural Resources Conservation Service. 1998. *National Engineering Handbook, Part 653, Stream Corridor Restoration*. Washington, DC.
- U.S. Department of Agriculture, Natural Resources Conservation Service. 2007. *National Engineering Handbook, Part 654, Stream Restoration Design Manual*. Washington, DC.
- U.S. Department of Agriculture, Natural Resources Conservation Service. 1997 *National Engineering Handbook, Part 651, Agricultural Waste Management Field Handbook, Appendix 10D*. Washington, DC. 31 pp.
- Ward, J.V. 1989. Riverine-wetland interactions. *In Freshwater Wetlands and Wildlife*. R.R. Sharitz and J. W. Gibbons (eds). DOE Symposium Series No. 61, CONF-860301, USDOE Office of Scientific and Technical Information, Oak Ridge, TN. pp. 385–400.
- Washington Department of Fish and Wildlife. 2000. *Fishway guidelines for Washington State*. Olympia, WA. 57 pp. Available at: <http://wdfw.wa.gov/hab/ahg/fishguid.pdf>.
- Washington Department of Fish and Wildlife. 2003. *Design of road culverts for fish passage*. Olympia, WA. 110 pp. Available at: http://wdfw.wa.gov/hab/engineer/cm/culvert_manual_final.pdf.
- Welcomme, R.L. 1985. *River fisheries*. Food and Agriculture Organization Fisheries Technical Paper 262. Food and Agriculture Organization of the United Nations, Rome, Italy.

-
- Welcomme, R.L. 1989. Floodplain fisheries management. *In* Alternatives in regulated river management. J.A. Gore, and G.E. Petts (eds). CRC Press. Boca Raton, FL. pp. 209–233.
- Wells, S.E., J.R., McClain, and T.D. Hill. 2002. Fish passage between Lake Erie and Metzger Marsh: Monitoring and experimental fish passage structure. 1999–2002 Final Report, U.S. Fish and Wildlife Service, Oak Harbor, OH.
- Whitlow, T.H., and R.W. Harris. 1979. Flood Tolerance in Plants. Technical Report E-79-2. U.S. Army Engineer Experiment Station, Vicksburg, MS. 161 pp.
- Willard, D.E., and R.B. Reed. 1986. The use of Native Species to Restore and Create Wetland Habitat for Mitigation. Proceedings: National Wetland Symposium; Mitigation of Impacts and Losses. Technical Report 3. Association of State Wetland Managers. Berne, NY. pp 340–342.
- Williams, P.B. 1986. Hydrology in Coastal Wetland Design. Proceedings: National Wetland Symposium; Mitigation of Impacts and Losses. Technical Report 3. Association of State Wetland Managers. Berne, NY. pp 329–336.
- Zedler, J.B., and J.C. Callaway. 1999. Tracking wetland restoration: Do mitigation sites follow desired trajectories? *Restoration Ecology* 7:69–73.

Aeolian	Earth materials deposited and shaped by wind.
Aerobic	The condition which exists when molecular oxygen is present.
Aesthetic quality	The societal value of a landscape as determined by the impression made on the mind and the meaning imparted from this impression.
Anaerobic	The condition which exists in the absence of molecular oxygen.
Anisotropy	A soil condition where the vertical hydraulic conductivity and horizontal hydraulic conductivity vary significantly. In most cases, the horizontal conductivity is greater than the vertical.
Alluvial	Earth materials deposited and shaped by streamflows.
Aquatic organism passage	The provision of connectivity of habitat for fish, herpetofauna, or mammals.
Aquifer	Water bearing stratum.
Available water capacity (AWC)	Amount of water held in the soil available for use by plants expressed a percent volume of water per unit volume of soil. The difference between field capacity and permanent wilting point.
Banquette	A berm at the toe of the landward side of a dike or levee constructed to provide structural stability.
Baseflow	Long-term streamflow rate which exists between storm runoff events. Water is provided by ground water discharge into the stream.
Bedload	The portion of the stream's sediment transport which is moved immediately above the streambed, consisting of coarse particles such as sand, gravel, or cobbles. The transport method is due to tractive stress imparted by the water column. Bedload material is too large to be in colloidal suspension in the water column.
Biological diversity	A function describing the sum of all species of plants and animals. An ecosystem is considered to be healthy when it when it maximizes the biological diversity potential for its HGM wetland class. In addition, biological diversity also refers to the genetic diversity found within individuals and populations of species and the diversity of ecosystems on a landscape scale.
Biomass	The total mass or amount of living organisms in a particular area or volume.
Buoyant force	Force acting upward on submerged structures equal to the weight of water displaced by the structure.
Capillary water	Water held in the soil voids against the force of gravity. Can be removed by plant root tension.
Channel-forming discharge	See geomorphic bankfull discharge.
Channel geometry	A stream channel's shape defined by parameters such as width, depth, sinuosity, area, and radius of curvature.
Channel incision	A condition resulting from a lowering of a stream's bed. Usually an indication of channel instability caused from erosion, interruption of sediment transport, or change in stream hydrograph.
Connectivity	The function that describes how a corridor or matrix is connected or spatially contiguous. Network connectivity is the degree to which all nodes in a system are linked by corridors.

Created wetland	See Wetland creation.
Depression	The wetland HGM class created by topographic depressions in an upland landscape position which store water for release by ground water outflow and/or evapotranspiration. Also, any topographic depression that stores water in the short or long term.
Detritus	Accumulation of decomposed organic debris.
Dike	Barrier, usually of earth, constructed to store water or prevent the entry of water from another location.
Dispersed clays	Clays that disperse or deflocculate easily and rapidly in water of low salt content. Usually high in absorbed sodium.
Dominant discharge	See Geomorphic bankfull discharge
Dominant water source	The source of water which has the dominant effect on the wetlands hydroperiod and hydrologic regime.
Drainable porosity	The ratio of the volume of water held in soil voids that can be removed by free drainage to a unit volume.
Drainage blocks	Structures installed for the purpose of reversing the effects of surface and surface drainage features.
Dry unit weight	The weight per unit volume of the air dry soil matrix.
Early successional stage	The earliest step in a continuum leading to a mature biological community.
Ecological community	An assemblage of species of a particular time and space.
Ecosystem	A functioning system that includes the organisms of a natural community together with their environment. Derived from "ecological system."
Ecotone	A relatively narrow overlap zone between two ecological communities.
Emergent	Dominated by erect, rooted, herbaceous plants, excluding mosses and lichens.
Endosaturation	Soil saturation caused by water entering the soil from beneath the soil surface.
Enhancement	See Wetland enhancement.
Episaturation	Soil saturation caused by water entering from the soil surface.
Estuarine	Of or relating to tidal estuaries.
Estuarine fringe	Wetland class in the HGM system existing in positions where tidal flows maintain wetland hydrology from sea water or tidally influenced freshwater.
Eutrophication	Process by which a lake or pond becomes rich in plant nutrient minerals and organisms but deficient in oxygen because of the oxygen demand created by decomposition of excess plants and organisms.
Evaporation	The conversion of water from liquid to water vapor, occurring at a free water surface or wet soil surface.
Evapotranspiration	The sum of evaporation from free water or wet soil surfaces and transpiration from plants.
Discharge wetlands	Depressional HGM class wetlands that gain more ground water inflow than they lose as ground water outflow.
Faunal	Relating to animals of a specified region or time.

Fetch	The distance across a body of open water in the direction of prevailing wind. This distance dictates the magnitude of waves that can impact a shoreline.
Field capacity	Amount held in the soil after free drainage has occurred which is available for uptake by plants, expressed as percent of water volume per unit volume of soil.
Fish passage	The provision of water flow of suitable depth, velocity, frequency, and duration for fish to move upstream, downstream, and into and out of flood plain habitats.
Fluvial	Influenced or formed by stream processes.
Freeboard	Height added to a constructed embankment to account for known or unknown factors which might cause overtopping by water during severe storm events.
Function	A process performed by a wetland. The process is described by a measurable variable or variables.
Functional assessment	Quantitative measurement of variables relating to wetland function and comparison of results to a reference condition.
Geomorphic bankfull discharge	The small range of streamflows responsible for forming the stream channel geometry. Flows in excess of this range enter the stream's flood plain, but do not occur frequently enough to do the majority of channel-forming work. Flows less than this range occur with high frequency, but do not provide enough stream power to do the majority of channel-forming work.
Geomorphic setting	The relative landscape position of a geologic element in relation to other elements, which was formed by the same physical process.
Geomorphology	The subdiscipline of geology that deals with the nature and origin of the Earth's topographic and near surface features.
Geotechnical investigation	Examination, testing, and documentation of surface and subsurface soil and rock for the purpose of determining engineering design parameters.
Geotextile	Manmade material that has permeability and strength properties suitable for use in conjunction with soil or rock as a part of a geotechnical system.
Gilgai	Microtopographic feature formed by the expansion and contraction of soils. Common to vertisols.
Gleyed	Descriptive term describing soils with bluish, greenish, or grayish colors resulting from removal of elemental iron from the soil matrix. Indicator of a hydric soil.
Ground water	Water existing below the ground surface in the voids of soil or rock.
Habitat fragmentation	The breakup of a large contiguous area of habitat into isolated patches that are not linked by corridors.
Herpetofauna	Reptiles and amphibians.
Hydraulic conductivity	Parameter that quantifies the ability of water to move through soil. Expressed in terms of distance versus time.
Hydric soil	Soils that are saturated for a sufficient frequency or duration to develop anaerobic conditions.
Hydrodynamics	The direction and flow rate of water movement.

Hydrogeomorphic (HGM)	System of classification that uses landscape position, dominant water source, and hydrodynamics to classify wetlands.
Hydrologic regime	The area of a wetland defined by a certain range of water depth.
Hydroperiod	The period of time, usually recurring seasonally, in which wetland hydrology exists in a wetland.
Interfluve	Landscape position that exists in areas between stream corridors.
Lacustrine	Of or relating to lakes.
Lacustrine fringe	Wetland class in the HGM system existing in locations where wetland hydrology is provided by lake water.
Landscape	A heterogeneous land area composed of a cluster of interacting ecosystems that are repeated in similar form throughout.
Landscape ecology	The study of the structure, function, and change in a landscape.
Landscape patterns	The arrangement of parts, elements, or details of the landscape that suggests a design of natural or human origin.
Landscape structure	The distribution of energy, materials, and species in relation to the sizes, shapes, numbers, kinds, and configuration of landscape elements or ecosystems.
Macrophyte	A megascopic plant, especially in an aquatic environment.
Macrotopography	Land surface features forming depressions deeper than 6 inches in height or depth.
Maintenance	Activities conducted to keep installed structural or vegetative practices at their original level of function or at some minimum sustained level of function.
Management	Activities conducted on a project, performed based on monitoring results that are needed to maintain or change function performance based on changing site conditions.
Microbes	Microscopic organisms.
Microtopography	Land surface features forming depressions shallower than 6 inches in depth.
Mineral soil flat	Wetland class in the HGM system existing in interfluves (uplands) and formed on nonorganic soils on flat or nearly flat landscapes.
Monitoring	Visual observation, measurement, testing, or remote sensing of site conditions on a periodic basis for the purpose of determining the performance and trend of functions and site conditions. Done to determine need for modification or maintenance on a project and to provide information for planning considerations for future projects on other sites.
Monostand	A single species plant community.
Mottles	See Redoximorphic features.
Muck	Soil with a significant fraction of decomposed plant material in which individual plant fibers can no longer be detected.
Organic soil	Soil with a significant fraction of decomposed plant material.
Organic soil flat	Wetland class in the HGM system existing in interfluves or extensive relic lake bottoms where the wetland hydrology is created by the accumulation of decomposed plant material.

Peat	Soil with a significant fraction of decomposed plant material in which individual plant fibers can still be detected.
Permanent wilting point	The water content of soil, expressed as percent of volume of water per unit volume of soil at which plants begin to expire due to lack of water.
Photosynthesis	The biological syntheses of chemical compounds in the presence of light.
Phreatic line	The level at which water appears in an open borehole.
Pore water	Water stored in the void spaces of the soil matrix.
Porosity	The ratio of the volume of voids in the soil (occupied by air or water) to a unit volume. A dimensionless parameter.
Precipitation	Rainfall or snowfall.
Propagule	Any piece of plant material that will form a new plant.
Quality assurance	System of oversight of a construction contractor provided to determine that quality control processes are adequate and documenting quality of completed work.
Quality control	System provided by a construction contractor to ensure that work is performed in accordance with contract plans and specifications.
Recharge wetlands	Depressional HGM class wetlands that gain less ground water inflow than they lose as ground water outflow.
Redoxomorphic features	Features formed by the processes of reduction, translocation, or oxidation of Fe and Mn oxides. Formerly called mottles and low chroma colors.
Redox potential	A measure of the potential electron exchange in the soil.
Restoration	See Wetland restoration.
Rhizosphere	The aerobic environment surrounding root hairs of hydrophytes.
Riparian	Of or relating to the physical and biological conditions existing adjacent to a stream, formed by and dependent upon stream processes.
Riverine	Wetland class in the HGM system existing on landscapes formed by stream processes.
Saturated unit weight	The weight per unit volume of the water saturated soil matrix.
Seedbank	Residual viable seeds, tubers, or propagules in or on the soil.
Slope	Wetland class in the HGM system existing on sloped landscape positions.
Soil bioengineering	The integrated use of plant materials with earth material to form a functioning system. Used to provide strength, stability, resistance to erosion, or durability to a part of the landscape.
Soil texture	The physical proportion of sand, silt, and clay size particles in the soil matrix.
Species diversity	A measure combining species richness with the evenness of distribution of species within an area (often confused with species richness).
Species richness	The number of different species within an area (often confused with species diversity).
Spillway	An open channel of earth, vegetated earth, or earth with armoring constructed for the purpose of safely conveying water past an embankment or structure for water control.

Stratigraphic slope wetland	Subclass of slope wetlands in the HGM system where wetland hydrology is caused by subsurface water forced to the surface by low permeability layers of soil or rock.
Stream corridor	Landscape position existing adjacent to streams, with hydrology, soils, geology, vegetation, and habitat formed by or dependent upon stream processes.
Structure for water control	A component of a water management system constructed to convey water, control the rate or direction of flow, or maintain a desired water surface.
Substrate	The soil foundation of a biological system.
Substrate anoxia	The condition of total lack of oxygen in the substrate.
Surface runoff	Water from precipitation which does not infiltrate into the soil and is not stored in local surface depressions.
Surface storage	Water stored above the ground surface in a topographic depression.
Tidal prism	The total volume of water entering and leaving a tidally influenced area due to the cyclic action of tides.
Topographic slope wetland	Subclass of slope wetlands in the HGM system where wetland hydrology is caused by subsurface forced to the surface by concave topography.
Transpiration	The discharge of liquid water from plant stems and leaves into the atmosphere as water vapor.
Tuber	A short, thickened, fleshy part of an underground stem.
Variable	A measurable parameter which describes a function, either alone or with other variables.
Vertical structure	The different height components within a vegetative community. May include herbs, shrubs, saplings, understory, canopy, and supracanopy species.
Water budget	The accounting of inflow, outflow, and storage of water.
Water control structure	See Structure for water control.
Wetlands	Lands that have a predominance or hydric soil are inundated or saturated by surface water or ground water at a frequency and duration sufficient to support a prevalence of hydrophytic vegetation typically adapted for life in saturated soil conditions and, under normal circumstances, do support a prevalence of hydrophytic vegetation (NFSAM).
Wetland creation	The creation of a wetland on a site that was historically nonwetland.
Wetland enhancement	The rehabilitation or reestablishment of a degraded wetland and /or the modification of an existing wetland that augments specific site conditions for specific species or purposes, possibly at the expense of other functions and other species.
Wetland restoration	The rehabilitation of a degraded wetland or the reestablishment of a wetland so that soils, hydrology, vegetative community, and habitat are a close approximation of the original natural condition that existed prior to modification to the extent practicable.

E	Evaporation from a free water or moist soil surface, expressed as volume or depth
ET	Water lost through the combination of evaporation and transpiration, expressed as volume or depth
f	Fetch, or distance of open water along the prevailing wind direction available for the formation of waves
H _d	Design height of a dike
H _f	Height added to a dike for freeboard
H _s	Height added to a dike for settlement
H _w	Maximum depth of water
H _v	Height added to a dike for wave height
K	Hydraulic conductivity, expressed as distance/time
K _{sat}	Hydraulic conductivity under saturated soil conditions, expressed as distance/time
K _h	Hydraulic conductivity in the horizontal plane
K _v	Hydraulic conductivity in the vertical plane
ΔS _s	Change in stored surface water
ΔS _p	Change in stored soil pore water
γ _d	Dry density, the ratio of the weight of soil solids to the unit volume, lb/ft ³
G _i	Volume of ground water flow into a wetland, expressed as volume or depth
G _o	Volume of ground water flow out of a wetland, expressed as volume
η	Porosity, the ratio of the volume of soil voids to the total unit volume, dimensionless
P	Precipitation
R _i	Volume of surface runoff into a wetland
R _o	Volume of surface runoff out of a wetland
S _p	Volume of water stored in soil pore spaces
S _s	Volume of stored surface water
T	Water lost from transpiration through plant leaves and stems
T _i	Volume of tidal flow into a wetland
T _o	Volume of tidal flow out of a wetland

Wetland Planning Checklist

1. What functions will be addressed at this restored or constructed wetland?

- _____ Dynamic surface water storage
- _____ Long-term surface water storage
- _____ Subsurface storage of water
- _____ Removal of imported elements and compounds
- _____ Retention of particulates
- _____ Maintain characteristic plant community
- _____ Maintain spatial structure of habitat
- _____ Maintain interspersion and connectivity
- _____ Maintain distribution and abundance of invertebrates
- _____ Maintain distribution and abundance of vertebrates
- _____ Rare and declining habitat

2. Have the following baseline data needs been met?

- (a) soils? Yes _____ No _____
- (b) water budget? Yes _____ No _____
- (c) water quality? Yes _____ No _____
- (d) existing vegetation? Yes _____ No _____
- (e) existing wildlife and fish? Yes _____ No _____
- (f) landscape context? Yes _____ No _____
- (g) wetland complex? Yes _____ No _____
- (h) aesthetic quality? Yes _____ No _____
- (i) _____ Yes _____ No _____
- (j) _____ Yes _____ No _____
- (k) _____ Yes _____ No _____

3. Are there limiting factors and constraints to restoring, enhancing, or creating the wetlands?

Yes _____ No _____

List limitation and constraints:

4. Are there related opportunities?

Yes _____ No _____

List related opportunities:

5. Has land user made decisions and examined alternatives for the planned wetland?

Yes _____ No _____

6. Are structures needed to restore or enhance the wetland to meet objectives or to control noxious, invasive, or plant and animal species?

Yes _____ No _____

7. Will planting be required to meet wetland objectives?

(a) Will wind and wave actions cause moderate to high wave energy conditions?

Yes _____ No _____

(b) Are plantings of specific species needed to speed early successional stages or to enhance the site for specific purposes?

Yes _____ No _____

(c) Are conditions suitable for application of soil bioengineering planting methods?

Yes _____ No _____

(d) Are noxious, invasive, or problem plant species in the soil seed/propagule bank on adjacent lands or accessible to the site by flooding?

Yes _____ No _____

(e) Will selected plant species be compatible with surrounding landscape?

Yes _____ No _____

(f) Are vegetated buffers, transition zones, or fences needed to protect the establishing wetland from human disturbance, excess sedimentation, pollutants, and/or intensive grazing pressures?

Yes _____ No _____

8. Can natural colonization of vegetation occur at the wetland? (Consult revegetation keys in tables 13-7 and 13-8.)

(a) Is an acceptable seed/propagule bank in the existing soil on site?

Yes _____ No _____

(b) Are plant materials that meet the targeted objectives and functions available from nearby or adjacent wetland sites and will readily disperse to the site?

Yes _____ No _____

(c) Will the wetland be built on nonhydric soil where seedbanks and other plant materials do not exist?

Yes _____ No _____

-
- (d) Are noxious, invasive, or problem plant species accessible to the site?
Yes _____ No _____
9. Are the targeted plant species appropriate for the planned site conditions?
- (a) Will they tolerate the expected water depths, flood frequencies, or fluctuating water tables?
Yes _____ No _____
- (b) Will they tolerate the expected water quality, salinity, acidity, and alkalinity?
Yes _____ No _____
- (c) Will they tolerate high velocity conditions?
Yes _____ No _____
- (d) Will they tolerate standing water conditions?
Yes _____ No _____
- (e) Are they compatible with planned landscape features, aesthetics, and other functions?
Yes _____ No _____
10. Are plant materials of **targeted** species available and of good quality?
- (a) Are seeds, transplants, or other propagules available in the needed quantities, or are substrate materials needed?
Yes _____ No _____
- (b) Will storage or stockpiling of plant materials be needed on site?
Yes _____ No _____
- (c) Have plant material costs been considered in the budget?
Yes _____ No _____
- (d) Can NRCS Plant Materials releases be used on the project, and are commercial sources of these materials available?
Yes _____ No _____
11. Is there an adequate water supply for the wetland?
- (a) Is too much water available, requiring a water control structure to prevent the wetland from drowning?
Yes _____ No _____
- (b) Are water rights assured?
Yes _____ No _____
- (c) Are there existing water quality problems that may limit the success or wetland restoration or enhancement activities?
Yes _____ No _____
12. Will soil amendments (fertilizers, lime, microbial enhancers) and mulch be required for adequate plant establishment?
Yes _____ No _____

13. Has the landuser been consulted about:

(a) Cropping/herbicide history?

Yes _____ No _____

(b) Current and past land uses?

Yes _____ No _____

(c) Ability to carry out construction work including avoiding compaction of soils in areas not to be disturbed?

Yes _____ No _____

(d) Ability to carry out planting work?

Yes _____ No _____

(e) Willingness to conduct simple monitoring of wetland progress?

Yes _____ No _____

(f) Willingness to carry out mid-course corrections and active wetland management?

Yes _____ No _____

(g) Landscape context?

Yes _____ No _____

(h) Wetland complex?

Yes _____ No _____

(i) Management?

Yes _____ No _____

14. Has conservation plan been developed and decisions been documented?

Yes _____ No _____

15. Has landowner been advised about needed permits (e.g., 404 permit)?

Yes _____ No _____

Monitoring Checklist

Observer _____ Date _____

Site name and location _____

Structure condition*Water control structures*

N/A _____

Structure in original condition?

Yes _____ No _____

Debris constricting flow?

Yes _____ No _____

Corrosion to concrete, metal parts?

Yes _____ No _____

Missing components?

Yes _____ No _____

Unauthorized alterations?

Yes _____ No _____

Description _____

_____*Embankments*

N/A _____

Vegetative cover adequate?

Yes _____ No _____

Rills, gullies

Yes _____ No _____

Wave erosion

Yes _____ No _____

Other: _____

Description _____

Nuisance plants and animals

Nuisance vegetation

Is nuisance vegetation reducing wetland function?

Yes _____ No _____

Description _____

Nuisance fish/animals

Are nuisance species of fish or animals reducing wetland function?

Yes _____ No _____

Description _____

Wetland hydrology

Is current hydroperiod and hydrologic regime consistent with planned functions for present season and climatic conditions?

Yes _____ No _____

Description _____

Wetland vegetation

Is current wetland plant community consistent with planned functions for age of project, season, and climatic conditions?

Yes _____ No _____

Description _____

Wetland wildlife use

Is current wildlife use consistent with planned functions for age of project, season, and current climatic conditions?

Yes _____ No _____

Description _____

Wetland landscape conditions

Have land use changes occurred adjacent to the wetland or in the wetland watershed which could affect:

water budget? Yes _____ No _____

water quality? Yes _____ No _____

wildlife use? Yes _____ No _____

vegetation? Yes _____ No _____

sediment delivery? Yes _____ No _____

structure function? Yes _____ No _____

structure safety? Yes _____ No _____

other wetland functions (list)

Description _____

Photographs:

Number	Date	Description
---------------	-------------	--------------------

Recommended actions:

Remarks:
